

## **A MESSAGE TO OUR CUSTOMERS:**

Our long awaited catalog is finally out. As a compliment to our New Catalog, we invite you to visit our web site at [www.salamint.com](http://www.salamint.com). Here you will find most everything you may need at your fingertips, just a click away, and we are constantly adding new products and you will find them there.

Since the inception of our company in 1992, which started with Autopsy Saw Blades and Scalpel Blades we have grown into a manufacturing company as well, with a tremendous variety of other quality products. We've been granted three (3) U.S. Patents. There are even greater products and ideas on the horizon.

We sincerely wish to thank our existing customers and friends for the continued support and trust you have given us throughout the years. We deeply appreciate the loyalty, guidance and friendship you have extended to us, and wish to welcome all our new customers.

kindest Regards,  
The Management

 **SALAM INTERNATIONAL, INC.**

# TABLE OF CONTENTS:

<b>1-6</b>	AUTOPSY SAWS - SAW BLADES - VACUUMS - EXTRACTION HOSE
<b>7-16</b>	SCALPEL HANDLES - BLADES - KNIVES - SHARPENERS
<b>17-62</b>	INSTRUMENTS & KITS
<b>63-64</b>	MEASURING - RULERS
<b>65-72</b>	INSTRUMENT TRAYS & ACCESSORIES
<b>73-74</b>	LINEN & BIOHAZARD LINERS
<b>75-80</b>	POST MORTEM NEEDLES - STAPLER- MARKER - THREAD - SYRINGES
<b>81-84</b>	LABORATORY SUPPLIES
<b>85-86</b>	UTILITY CARTS
<b>87-100</b>	SCALES
<b>101-116</b>	PROTECTIVE APPAREL
<b>117-122</b>	GLOVES
<b>123-136</b>	DISASTER POUCHES - SHROUDS - SHEETS - ID BANDS
<b>137-140</b>	PREP ROOM INSTRUMENTS
<b>141-158</b>	FERNO MORTUARY EQUIPMENT
<b>159-166</b>	MORGUE - DISSECTING TABLES & ACCESSORIES
<b>167-186</b>	MORGUE - CARRIERS - AUTOPSY CARTS
<b>187-192</b>	MORGUE - TRAYS & TOPS
<b>193-202</b>	MORGUE - AUTOPSY TABLES
<b>203-212</b>	MORGUE - SINK STATIONS
<b>213-220</b>	MORGUE - PATHOLOGY - GROSSING STATIONS - EVIDENCE DRYING CABINETS - FUME HOOD MODULES
<b>221-226</b>	MORGUE - STORAGE
<b>227-232</b>	MORGUE - CADAVER LIFTS



## ELECTRIC AUTOPSY SAW

Model No. 1200 115 VAC 60HZ



Our Oscillating Autopsy Saw is a specialized tool designed for rugged use. It is lightweight, providing precisely what is needed for autopsy room i.e., power, speed, quiet operation, durability, ease of operation and better balance of weight and power. Enhanced weight distribution decreases user fatigue. A hexagonal drive shaft has been utilized to provide positive drive and prolong blade life. When necessary, the blade may be changed quickly and easily.

### NO ARBOR REQUIRED

#### FEATURES

- Increased Power
- Reduced Noise Level
- Special Lubrication
- Non-Metallic Motor Housing
- Switch Design & Placement
- Rugged Construction
- Hexagonal Blade Drive
- Positive Lock Nut

#### BENEFITS

- Runs Cool for a Longer Time
- Longer lasting and More Comfortable to Use
- Reduced Heat and Noise
- More Durable, Prevents Accidental Start-ups
- Reduced Down-Time
- Positive Up to 6-way Attachment
- No Extra Wear on Motor Shaft

#### ACCESSORIES

- Aerosolized Bone Dust & Body Fluid Extraction System Reducing Significantly the Risk of Inhaling Infectious Bone Dust and Fluids.
- Bone Dust Collector

#### SPECIFICATIONS

- Size: 11" Long
- Electrical Cord : 10' with Hospital Grade Plug
- Weight : 3 lbs 4 oz
- Shipping Weight : 6 lbs
- Contents : Autopsy Saw with 10' Cord, One Large
- Sectioned Blade, Wrench, Owner's Manual

- Hardest Steel to Reduce Bending
- Ground to Perfection for Long Life
- Competitively Priced to Meet Budgets
- Easier on all Saws and Technicians



**CAT No. 201-102**  
Large Sectioned Blade



**CAT No. 201-101**  
2 1/2" Round Blade



**CAT No. 201-103**  
Spinal Column Blade



**CAT No. 201-202**  
Large Sectioned Blade  
with Arbor



**CAT No. 201-201**  
2 1/2" Round Blade  
with Arbor



**CAT No. 401-102T**  
Titanium Large  
Sectioned Blade



**CAT No. 401-101T**  
2 1/2" Round Autopsy  
Blade



**CAT No. 201-250**  
Arbors For All  
Saw Blades

Autopsy Saws - Saw Blades - Vacuums - Extraction Hose

# AUTOPSY & CAST SAW REPAIRS

## Call for pricing

Armature & Field Coil Rewinding  
Brushes, Bearings, Switches  
Gaskets, Cords, Plugs  
Cleaning and Testing  
Cam, Shaft, Shaft Link\*\*  
90 Day Warranty

Ship Saws To:  
SALAM INTERNATIONAL, INC.  
Repair Department  
19781 Pauling  
Foothill Ranch, CA 92610

Before Shipping Saws for Repair:  
Please Disinfect Saw  
Remove Blade  
Pack securely  
Include Description of Problem & Serial No.

\* Plus Shipping

\*\* At Additional Cost, When Necessary

Offer Can be withdrawn anytime without notice, not responsible for typographical errors.

## GS801 BONE DUST COLLECTOR DRY

**REDUCES THE RISK OF INHALING AIRBORNE INFECTIOUS CONTAMINATED MATERIAL FOR DRY ONLY MATERIALS, SUCH AS BONE DUSTS  
A UNIQUE BAG AND POLY LINER DISPOSAL SYSTEM INSURES A SANITARY PROCESS**

### FEATURES:

1. In this first stage of separation, a 2 ¼ gallon capacity disposal paper bag captures the bulk of collected debris.
2. Extra-large main filter assures a steady, even airflow which extends filter life and eliminates premature clogging.
3. This microfilter, a final step in pre-filtration, protects the motor and acts as a barrier to even bacteria-size particulates.
4. \*HEPA filter assures that 99.97% of all ultrafine particulates, toxic and nuisance, are retained-down to and including 0.3 microns. Meets ANSI Z9.2-1971 standards.
5. Motor thermo-valve prevents overheating caused by failure to keep filters clean or by accidental blockage in a nozzle or hose. Whistles to operator if there's a problem.
6. Ball-joint couplings give 360 degree freedom of movement without hoses splitting and cracking, and eliminates knots.
7. Heavy-duty trolley adds mobility. Glides over all surfaces. Detaches for use on stairs.



GS801 SPECIFICATIONS	
Motor Type, double insulated/grounded	
GSD/GSJ Voltage, volts	: 115/220
Current draw, amps	: 7.8/3.9
Watts consumed	: 700
Waterlift, inches	: 75
Air flow, cubic ft/min	: 87
Tank capacity, gallons dry bulk	: 3 ¼
Paper bag capacity, gallons dry bulk	: 2 ¼
Filter area, square inches*	: 1620
Height, inches	: 16
Width, inches	: 12
Weight without accessories, lbs	: 13 ¼
Sound level, db(A) at 6 ½ ft from vacuum	: 67

\* Filter area includes paper bags, main filter, microfilter, HEPA or ULPA  
Standard accessories: Microfilter, detachable trolley, paper bags and 30' cord

## SAL-786 DUST and FLUID EXTRACTION ATTACHMENT

(Patent No. 6,013,079)

This extraction hose was designed after months of research and development. A water tube brings water or decontaminant solution into the Extractor Hood Assembly, thereby decontaminating hazardous particulates in the Extractor Hood Assembly. It also aids in smoother cutting and helps bring airborne particulates into the vacuum holding tank. The water flow to the spray jet installed in the Extractor Hood Assembly is controlled by a valve installed on the hose.

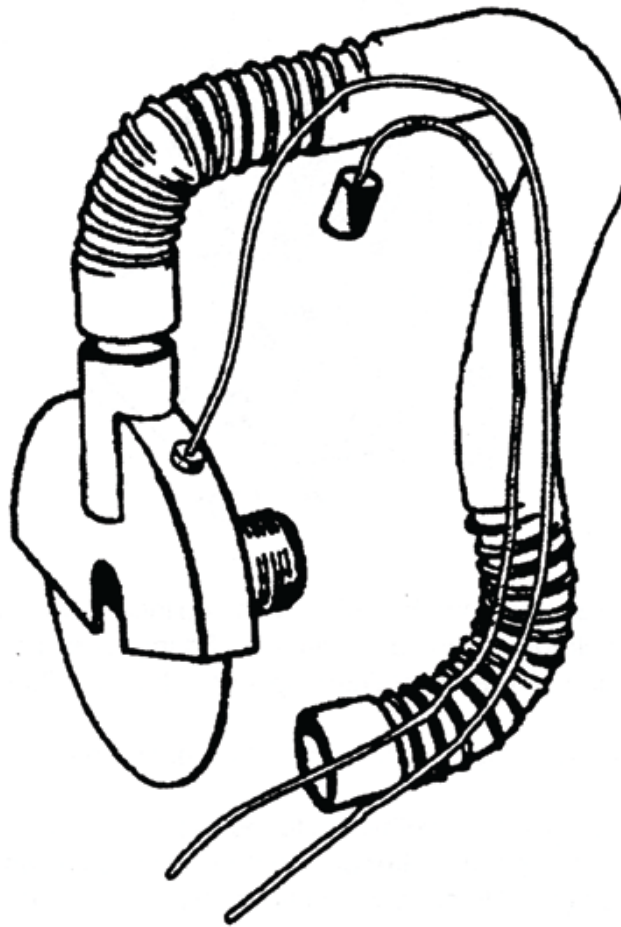

ALL SPRAY - VAC EXTRACTION SYSTEMS REQUIRE THIS ATTACHMENT

## BONE DUST COLLECTOR PART # SAL-0295420 Designed to Attach to Various Autopsy Saws



### STANDARD FEATURES:

The Lightweight Bone Dust Collector can easily be rolled from place to place. Harmful air-borne pathogens are trapped in a uniquely designed disposable HEPA filter. The vacuum motor is wired to start when the saw is turned on.

### BONE DUST COLLECTOR:

SPECIFICATIONS	
• Reduced Noise Level	
• Disposable Filter Cartridge	
• Electrical	: 115 volt, 8.5 Amps
• Electrical Cord Length	: 10 Foot Cord

\* When Ordering Please specify What Type of Autopsy saw will be used with the Bone Dust Collector

Autopsy Saws - Saw Blades - Vacuums - Extraction Hose



# SCALPEL HANDLES

Additional blades & handles not listed in this catalog also available to order please call for more information.

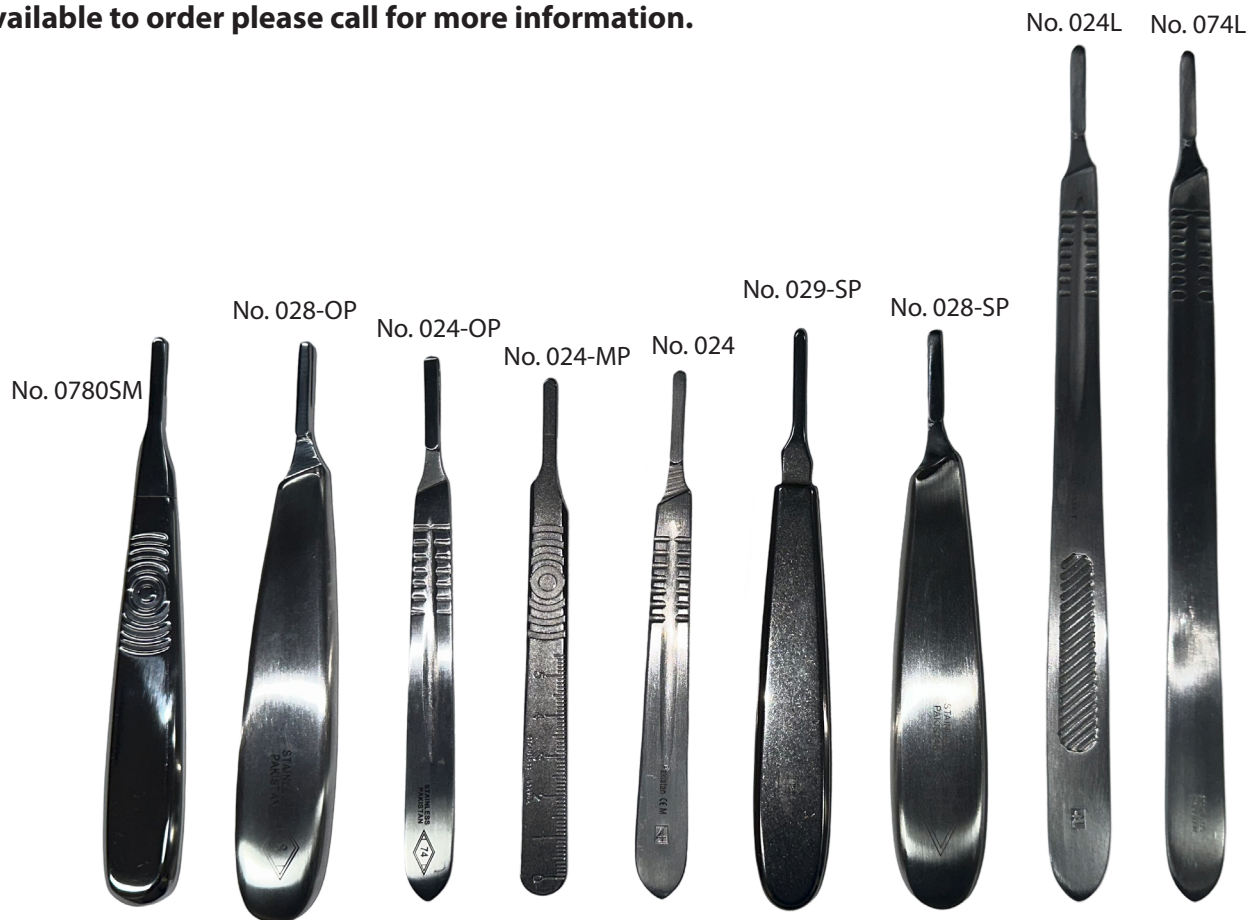

CAT NO.	SIZE	BLADE
024	4	#20-25
024L	4L	#20-25
074L	4L	#22RD, 20-25, 60



CAT NO.	SIZE	BLADE
026	Red Molded No. 6	#20-25



CAT NO.	SIZE	BLADE
028PH	Blue Molded No. 8	#60, 70

CAT NO.	SIZE	BLADE
029-SP	09S	#20-25
028- SP	6	#20-25
024P	4	#20-25
024MP	4 (metric)	#20-25
024LP	4L	#20-25
024-OP	4	#22RD, 60, 70
028-OP	8	#22RD, 60, 70
0780SM	AUTOPSY	#60, 70

## HANDLES - BARD PARKER

- Molded Blade Holder
- 5 Handles / Box



CAT NO.	SIZE	BLADE
BP37-1080	8	#60 & 70
BP37-1060	6	#20-23

## SCALPEL BLADES - BARD PARKER - STERILE BLADES

CAT NO.	DESCRIPTION	BLADE SIZE
BP37-1121	Rib-Back Carbon Steel Blades	21
BP37-1122	Rib-Back Carbon Steel Blades	22
BP37-1221	Stainless Steel Blades	21
BP37-1222	Stainless Steel Blades	22

Packaged 150 Blades / Case (3 Packs of 50)

## DISPOSABLE SCALPELS with HANDLES

- Stainless steel blade on a uniquely designed handle.
- Each scalpel is supplied with a flexible blade cover for complete protection.
- Each unit is disposable.

### STERILE

CAT NO.	SIZE
160-520	20
160-521	21
160-522	22

- Additional Sizes Available
- Stainless Steel Blade
- 10 Blades / Box



### NON - STERILE

CAT NO.	SIZE
160-620	20
160-621	21
160-622	22

- Additional Sizes Available
- Stainless Steel Blade
- 10 Blades / Box



## SCALPEL BLADES

## • ECONOMY

CAT NO.	DESCRIPTION	BLADE SIZE
ST010E	Sterile	10
ST011E	Sterile	11
ST012E	Sterile	12
ST015E	Sterile	15
ST020E	Sterile	20
ST021E	Sterile	21
ST022E	Sterile	22
ST023E	Sterile	23
ST024E	Sterile	24
ST025E	Sterile	25

- CARBON STEEL, 100 / Box

## • PREMIUM

CAT NO.	DESCRIPTION	BLADE SIZE
ST020	Sterile	20
ST021	Sterile	21
ST022	Sterile	22
ST022RD	Sterile, Round	22
ST023	Sterile	23

- STAINLESS STEEL, 100 / Box

## • PREMIUM

CAT NO.	DESCRIPTION	BLADE SIZE
NS020	Non-Sterile	20
NS021	Non-Sterile	21
NS022	Non-Sterile	22
NS023	Non-Sterile	23
NS060	Non-Sterile	60
NS070	Non-Sterile, Round	70

- CARBON STEEL, 100 / Box



No. 22RD



No. 70



No. 23



No. 60



No. 20



No. 21



No. 22

**Blade removers reduce the risk of injury and infection.  
This unit may be safely autoclaved and disposed of in a proper manner**

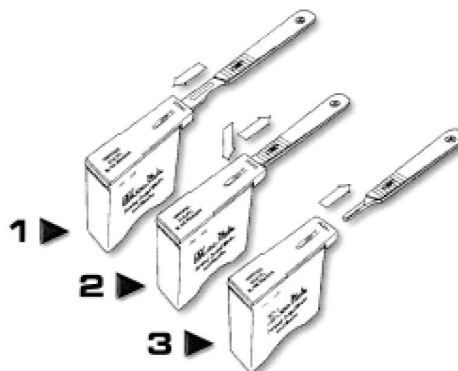

CAT NO.	DESCRIPTION
333-080	QTY: 10 / Box

## BLADE REMOVER

- Removes blades easily and safely from any style surgical handle.

CAT NO.
333-090



## QLICKSMART® Blade Remover

- The Single Handed Surgical Blade Remover, The Safest Way to Remove Scalpel Blades**
- QlickSmart offers single-handed removal and immediate containment of scalpel blades.
- Holds 100 blades in a sealed container, simply replace the container when full.



CAT NO.
333-092

- Complies with OSHA Bloodborne Pathogens Standards
- All commonly used handles: #3, #3L, #4, #4L, #5, #7, #9
- All commonly used blades: #10, #10A, #11, #12, #13, etc. up to and including #25
- 100 blades

### Optional Accessories:

- Mounting Bracket: Ideal for wall or bench mounting."

CAT NO.
333-094

## AUTOPSY GROSSING KNIVES

### EDGE:

- A Granton Edge or "kullenschliff" edge has hollowed out grooves (air gaps) on both sides of the blade. These grooves fill with fat and fluid which allows for thin even cuts without tearing and shredding tissue. A straight edge blade is hardened, tempered, ground, polished, etched and finished. Features: 3/4" or 7/8" tang. Knives are thicker on top, thinner and extremely sharp on the edge.

### HANDLES:

- Ergonomically designed to minimize wrist tension. Nylon and patented Fibrox handles are NSF approved and slip resistant.

### SHARPNESS:

- Special tempering process produces an edge that can be sharpened repeatedly. The knife keeps its original sharpness throughout its life.

### HYGIENE:

- Materials and construction details of the handle minimize crevices that would offer hospitality to bacteria.
- **CLEANING:** Fibrox and Santoprene handles are NSF approved. Sani-Safe Autopsy knives can be sanitized with all disinfectants.
- Autoclavable

### STRAIGHT EDGE

- STAINLESS STEEL,
- 1.5" Width at Handles

CAT NO.	DESCRIPTION	SIZE
3-3120	Straight	7" Long
3-3122	Straight	8" Long
3-3124	Straight	10" Long
3-3126	Straight	12" Long
3-3125	Curved	10" Long
3-3127	Curved	12" Long



### GRANTON EDGE, ROUND BLADE

- STAINLESS STEEL,
- 1.5" Width at Handles

CAT NO.	DESCRIPTION	SIZE
3-3102	Round	12" Long
3-3104	Round	14" Long



### GRANTON EDGE, POINTED TIP

- STAINLESS STEEL,
- 1.5" Width at Handles

CAT NO.	DESCRIPTION	SIZE
3-1110	Boning, Wide, Stiff	6" Long
3-3115	Straight	12" Long
3-3117	Curved	10" Long
3-3118	Curved	12" Long



## MACRO-PREP KNIVES, DISPOSABLE

- Stainless Steel Blade, Double Honed Edge Assures the Finest Quality
- Strong Flexible Blade
- Non-Slip Handle Gives User Precise Control and Accuracy
- May be Stropped for Longer Lasting Edge
- Disposable Knives
- Packaged in Reusable Box that may be used for Tissue Block Storage

CAT NO.	DESCRIPTION	QTY
3-5004	4.0" Blade	10 / Box
3-5006	6.0" Blade	10 / Box
3-5000	8.0" Blade	10 / Box
3-5010	10.0" Blade	10 / Box
3-5012	12.0" Blade	10 / Box
3-5014	Assorted Set - 2 of Each	10 / Box



**WHEN PRECISION COUNTS, USE ONLY THE BEST!**

Scalpel Handles - Blades - Knives - Sharpeners

## DISSECTING KNIFE

CAT NO.	DESCRIPTION
3-370	160 mm Long x 15 mm Wide, 3 mm Thick at Center

- Stainless Steel Blade
- A Sturdy Fine Quality Instrument
- Easy Grip Handle
- Blades Top Half Has an Edge



### STANDARD 15 mm

CAT NO.	BLADE SIZE
3-330	200 mm x 15 mm
3-332	150 mm x 15 mm
3-334	90 mm x 15 mm
3-335	COMPLETE SET - 3

### STANDARD 20 mm

CAT NO.	BLADE SIZE
3-336	250 mm x 20 mm
3-338	200 mm x 20 mm
3-340	150 mm x 20 mm
3-341	COMPLETE SET - 3



## PREMIUM DISSECTING KNIVES

- Fine Quality Stainless Steel Blade, Light Weight Handle for a Firm Grip
- Flat Tapered Ground with Full Back Thickness for Maximum Strength



CAT NO.	BLADE SIZE
3-320	250 mm x 20 mm
3-322	200 mm x 20 mm
3-324	150 mm x 20 mm
3-326	COMPLETE SET - 3

## LISTON AMPUTATING KNIVES

- Stainless Steel

CAT NO.	DESCRIPTION	SIZE
3-440	6.5" Blade	11.75"
3-442	8.0" Blade	13.75"



## SPECIMEN KNIFE (RATCLIFF)

- Sturdy Balanced Stainless Steel
- Blade is Approx. 18"(3 mm), Thick in back, Gradually Tapered to a Keen Edge.

CAT NO.	DESCRIPTION
3-396	8" Blade
3-398	With Rule Attached Marked in mm & 10 cm Long, 8.0" Blade.



## VIRCHOW POST MORTEM KNIFE

- Fine Quality Stainless Steel Knives

CAT NO.	BLADE SIZE
333-226	12.5" Blade Length: 6.25" (16.0 cm)
333-228	13" Blade Length: 8" (20.0 cm)
333-230	15" Blade Length: 9.5" (24.0 cm)





**GANNET'S POST MORTEM KNIFE**

- Stainless Steel Blade, Excellent Quality Instrument
- 5" Long, 1.5" Wide, 10 mm Thickness

**CAT NO.**

3-400

**DUBLIN MODEL KNIFE**

- Stainless Steel Blade, Single Edge, Flexible Blade
- Flat Ground, 14" Long, 1.5" Wide

**CAT NO.**

3-350

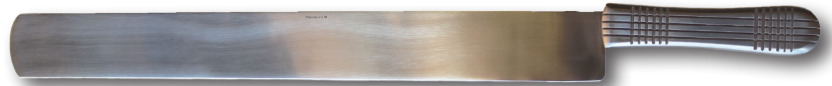
**POST MORTEM KNIFE, SINGLE EDGE**

- Stainless Steel, Single Edge, Easy Handle, Knife Back
- 5 mm Thick 1.25" Wide Blade

**CAT NO.**

3-410

**BLADE LENGTH**

5.0"

3-412

8.0"

**POST MORTEM KNIFE, DOUBLE EDGE**

- Flexible Stainless Steel Blade, Double Edge, Flat Ground

**CAT NO.**

3-380

**BLADE SIZE**

180 mm x 25 mm

3-382

250 mm x 40 mm

**EXTRA HEAVY POST MORTEM KNIFE**

- Fine Stainless Steel
- Handle is Large and Well Balanced with an Easy Grip

**CAT NO.**

3-390

**DESCRIPTION**

Blade is 1/8" Thick, 1.5" Wide and 18" Long

## EZE-LAP DIAMOND STEEL, KNIFE SHARPENER

- Stainless Steel, Grooved Black Plastic Non-Slip Handle
- Removes Metal with Each Stroke Generating a New Cutting Edge.
- Reduces Grinding and Honing to a Minimum.

CAT NO.	SHAFT SIZE
3-3300	10.5" Shaft



## DICKORON STEEL, KNIFE SHARPENER

- Hard Chrome Stainless Steel
- Non-Breakable Handle
- Super-Fine Cut
- Nickel Plated Drop Ring with Diamond-Shaped Guard

CAT NO.	SHAFT SIZE
3-3202	14" Round



## ELECTRIC SCISSORS SHARPENER, SCISSORSPRO

A revolutionary development in scissor sharpening. Produces professional quality sharpness with unparalleled simplicity for incredibly sharp scissors. Sharpens without the need to disassemble scissors 100% Diamond abrasives for superior results. Double beveled edge stays sharp longer. Safe for quality scissors. Never detempers your scissors.

CAT NO.
3-355



## KNIFE SHARPENERS, AngleSelect™ Diamond Hone™

- The Worlds Most Versatile Easy to Use Sharpener
- Designed to sharpen Asian, European and American knives. Engineered to provide sharp edges using highly precise knife guides that automatically position the knife.
- Quickly and easily sharpens all quality cutlery.
- Features 100% diamond abrasives

CAT NO.
3-351





**SUPERCUT SCISSORS**

The SuperCut Scissors are made from the finest German Stainless Steel. With a specially designed razor sharp blade that cuts easily thru tissue

**DISSECTING SCISSORS**

- Premium

CAT NO.	DESCRIPTION	SIZE
333-108SC	Straight Sharp/Blunt	5.5"
333-126SC	Curved Sharp/Blunt	5.5"

**MAYO SCISSORS**

- Premium

CAT NO.	DESCRIPTION	SIZE
333-150SC	Straight	5.5"
333-152SC	Straight	6.75"
333-154SC	Straight	9.0"
333-156SC	Curved	5.5"
333-158SC	Curved	6.75"
333-160SC	Curved	9.0"

**IRIS SCISSORS**

- Premium

CAT NO.	DESCRIPTION	SIZE
333-170SC	Straight	4.5"
333-172SC	Curved	4.5"

**METZENBAUM SCISSORS**

- Premium

CAT NO.	DESCRIPTION	SIZE
333-183SC	Curved	5.5"
333-185SC	Curved	7.0"
333-187SC	Curved	9.0"
333-191SC	Straight Blunt/Blunt	5.7"



## TUNGSTEN CARBIDE SCISSORS

Tungsten Carbide cutting is one of the finest cutting scissors, edges provide effortless, yet accurate cuts through the toughest of autopsy or surgical tissue. The finger rings are well rounded and polished, while scissor shanks are tempered to the ideal hardness

## DISSECTING SCISSORS

- Premium

CAT NO.	DESCRIPTION	SIZE
333-108TC	Straight Sharp/Blunt	5.5"
333-120TC	Straight Sharp/Sharp	5.5"
333-126TC	Curved Sharp/Blunt	5.5"
333-132TC	Curved Sharp/Sharp	5.5"



## MAYO SCISSORS

- Premium

CAT NO.	DESCRIPTION	SIZE
333-150TC	Straight	5.5"
333-152TC	Straight	6.75"
333-154TC	Straight	9.0"
333-156TC	Curved	5.5"
333-158TC	Curved	6.75"
333-160TC	Curved	9.0"



## IRIS SCISSORS

- Premium

CAT NO.	DESCRIPTION	SIZE
333-170TC	Straight	4.5"
333-172SC	Curved	4.5"

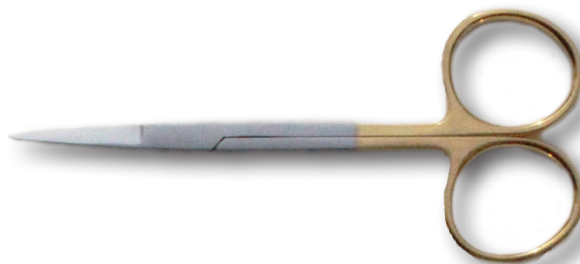

## METZENBAUM SCISSORS

- Premium

CAT NO.	DESCRIPTION	SIZE
333-183TC	Curved	5.5"
333-185TC	Curved	7"
333-186TC	Curved	8"
333-187TC	Curved	9"
333-188TC	Curved	11"
333-190TC	Curved	5.5"
333-192TC	Straight	7"
333-196TC	Straight	9"



## DISSECTING STRAIGHT SHARP / SHARP

- **Standard**

CAT NO.	SIZE
3-100	4.5"
3-102	5.5"
3-104	6.5"

- **Medium**

CAT NO.	SIZE
33-100	4.5"
33-101	5.0"
33-102	5.5"
33-104	6.5"

- **Premium**

CAT NO.	SIZE
333-100	4.5"
333-101	5.0"
333-102	5.5"
333-104	6.5"



## CURVED SHARP / SHARP

- **Standard**

CAT NO.	SIZE
3-118	4.5"
3-120	5.5"
3-122	6.5"

- **Medium**

CAT NO.	SIZE
33-118	4.5"
33-119	5.0"
33-120	5.5"
33-122	6.5"

- **Premium**

CAT NO.	SIZE
33-118	4.5"
33-119	5.0"
33-120	5.5"
33-122	6.5"



## DISSECTING

### STRAIGHT SHARP / BLUNT

- **Standard**

CAT NO.	SIZE
3-106	4.5"
3-107	5.0"
3-108	5.5"
3-110	6.5"

- **Medium**

CAT NO.	SIZE
33-106	4.5"
33-107	5.0"
33-108	5.5"
33-110	6.5"

- **Premium**

CAT NO.	SIZE
333-106	4.5"
333-107	5.0"
333-108	5.5"
333-110	6.5"

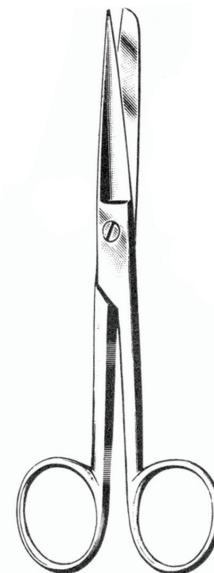

### CURVED SHARP / BLUNT

- **Standard**

CAT NO.	SIZE
3-124	4.5"
3-125	5.0"
3-126	5.5"
3-128	6.5"

- **Medium**

CAT NO.	SIZE
33-124	4.5"
33-125	5.0"
33-126	5.5"
33-128	6.5"

- **Premium**

CAT NO.	SIZE
333-124	4.5"
333-125	5.0"
333-126	5.5"
333-128	6.5"
333-129	7.5"



**DISSECTING****STRAIGHT BLUNT / BLUNT**• **Standard**

CAT NO.	SIZE
3-112	4.5"
3-114	5.5"
3-116	6.5"

• **Medium**

CAT NO.	SIZE
33-112	4.5"
33-113	5.0"
33-114	5.5"
33-116	6.5"

• **Premium**

CAT NO.	SIZE
333-112	4.5"
333-113	5.0"
333-114	5.5"
333-116	6.5"

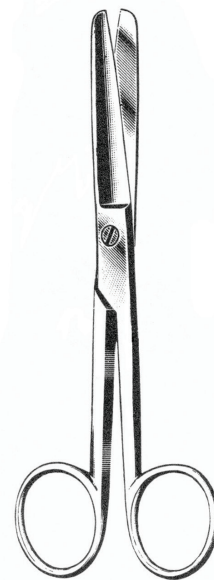
**CURVED BLUNT / BLUNT**• **Standard**

CAT NO.	SIZE
3-130	4.5"
3-132	5.5"
3-134	6.5"

• **Medium**

CAT NO.	SIZE
33-130	4.5"
33-131	5.0"
33-132	5.5"
33-134	6.5"

• **Premium**

CAT NO.	SIZE
333-130	4.5"
333-131	5.0"
333-132	5.5"
333-134	6.5"



## MAYO DISSECTING SCISSORS

- **Standard**

CAT NO.	SIZE
3-150	5.5"
3-152	6.75"
3-154	9.0"

- **Medium**

CAT NO.	SIZE
33-150	5.5"
33-152	6.75"
33-154	9.0"

- **Premium**

CAT NO.	SIZE
333-150	5.5"
333-152	6.75"
333-154	9.0"



## MAYO DISSECTING SCISSORS

- **Standard**

CAT NO.	SIZE
3-156	5.5"
3-158	6.75"
3-160	9.0"

- **Medium**

CAT NO.	SIZE
33-156	5.5"
33-158	6.75"
33-160	9.0"

- **Premium**

CAT NO.	SIZE
333-156	5.5"
333-158	6.75"
333-160	9.0"



**WE MAINTAIN STOCK LEVEL FOR MOST ITEMS**

**MAYO-NOBLE DISSECTING SCISSORS**

- Stainless Steel, Rounded Blades, 6.5" Length

- **Medium**

CAT NO.	DESCRIPTION
333-1100	Straight
333-1102	Curved



- **Premium**

CAT NO.	DESCRIPTION
333-1100	Straight
333-1102	Curved

**MAYO-NOBLE DISSECTING SCISSORS**

- Stainless Steel, Beveled Blades, 6.5" Length

- **Premium**

CAT NO.	DESCRIPTION
333-1104	Straight
333-1106	Curved



**MOST ITEMS ARE READY TO SHIP  
OTHER GRADES AVAILABLE**



## METZENBAUM SCISSORS

- Stainless Steel Straight

- **Standard**

CAT NO.	SIZE
3-190	5.5"
3-192	7.0"
3-194	8.0"
3-196	9.0"
3-198	11.0"

- **Medium**

CAT NO.	SIZE
33-190	5.5"
33-192	7.0"
33-194	8.5"
33-196	9.0"
33-198	11.0"

- **Premium**

CAT NO.	SIZE
333-192	7.0"
333-194	8.0"
333-196	9.0"
333-198	11.0"



- **Curved**

- **Standard**

CAT NO.	SIZE
3-184	5.5"
3-185	7.0"
3-186	8.0"
3-187	9.0"
3-188	11.0"

- **Medium**

CAT NO.	SIZE
33-183	5.5"
33-185	7.0"
33-186	8.5"
33-187	9.0"
33-188	11.0"

- **Premium**

CAT NO.	SIZE
333-183	5.5"
333-185	7.0"
333-187	9.0"
333-188	11.0"





**DOYEN ABDOMINAL SCISSORS**

- Stainless Steel

- **Standard**

CAT NO.	DESCRIPTION	SIZE
3-200	Straight	7.0"
3-202	Curved	7.0"

- **Medium**

CAT NO.	DESCRIPTION	SIZE
33-200	Straight	7.0"
33-202	Curved	7.0"

- **Premium**

CAT NO.	DESCRIPTION	SIZE
333-200	Straight	7.0"
333-202	Curved	7.0"

**DUBOIS DECAPITATION SCISSORS**

- Stainless Steel, Extra Heavy Pattern. Blunt points. 10.5" Length

- **Standard**

CAT NO.	DESCRIPTION
3-210	Straight

**ENTEROTOMY SCISSORS**

- Stainless Steel, 8" Length

- **Standard**

CAT NO.	DESCRIPTION
3-140	Probe Tip
3-142	Hook Blade



- **Premium**

CAT NO.	DESCRIPTION
333-140	Probe Tip
333-142	Hook Blade



## LISTER BANDAGE SCISSORS

- Stainless Steel

- **Standard**

CAT NO.	DESCRIPTION	SIZE
3-889	As Pictured	3.5"
3-890	As Pictured	4.5"
3-891	As Pictured	5.5"
3-892	As Pictured	7.5"
3-894	Left Handed	5.5"
3-895	One Large Ring	7.5"
3-897	One Large Ring	8.0"

- **Medium**

CAT NO.	DESCRIPTION	SIZE
33-890	As Pictured	4.5"
33-891	As Pictured	5.5"
33-893	As Pictured	7.25"
33-894	As Pictured	8.0"
33-896	One Large Ring	7.5"
33-897	One Large Ring	8.0



## HARRINGTON SCISSORS

- Stainless Steel, 11.5" Length

- **Premium**

CAT NO.	DESCRIPTION
333-1200	Straight
333-1202	Curved



**IRIS SCISSORS**

- Stainless Steel, 4.5" Length

- **Standard**

CAT NO.	DESCRIPTION
3-170	Straight
3-172	Curved
3-176	Angular 2 Sharp Pts.
3-180	Angular, One Sharp One Probe Pt.
3-182	Angular, 2 Probe Pts.

- **Medium**

CAT NO.	DESCRIPTION
33-170	Straight
33-172	Curved
33-176	Angular 2 Sharp Pts.
33-180	Angular, One Sharp One Probe Pt.
33-182	Angular, 2 Probe Pts.

- **Premium**

CAT NO.	DESCRIPTION
333-170	Straight
333-172	Curved
333-174	Angular
333-180	Angular, Probe Pt
333-182	Angular, 2 Probe Pts.

**ROGER WIRE SCISSORS**

- Stainless Steel
- Straight or Angled to One Side, One Serrated Blade 4.75" Length

- **Standard**

CAT NO.	DESCRIPTION
3-1500	Straight
3-1502	Angular



## VEZIEN'S ABDOMINAL SCISSORS

- Stainless Steel, Curved Sideways, Serrated, 6.5"

- **Standard**

CAT NO.	SIZE
3-220	6.5"



## RICHTER DISSECTING SCISSORS

- Stainless Steel, Sharp / Blunt, 5.0"

- **Premium**

CAT NO.	DESCRIPTION
333-1300	Angular Blades



## ALL PURPOSE UTILITY SCISSORS

- Stainless Steel, Autoclavable

- **Standard**

CAT NO.	SIZE
3-900	5.5"
3-902	7.5"

- **Medium**

CAT NO.	SIZE
33-900	5.5"
33-902	7.5"

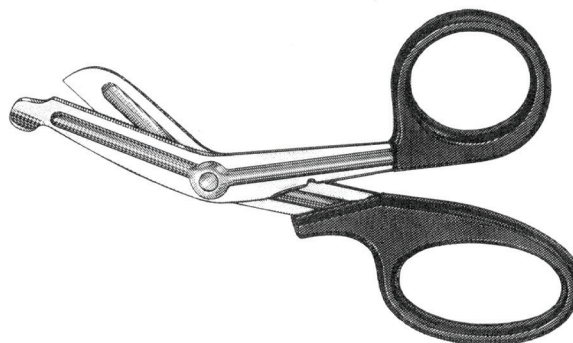

## SPENCER SUTURE SCISSORS

- Stainless Steel, Autoclavable

- **Standard**

CAT NO.	SIZE
3-910	3.5"

- **Medium**

CAT NO.	SIZE
33-912	3.5"

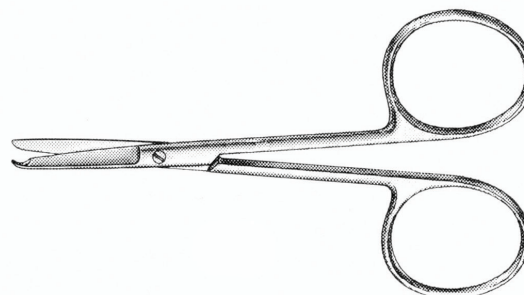

## TISSUE FORCEPS

- Stainless Steel

### • Standard

CAT NO.	TEETH	SIZE
3-660	1 x 2 Teeth	4.5"
3-662	1 x 2 Teeth	5.0"
3-664	1 x 2 Teeth	5.5"
3-666	1 x 2 Teeth, Fine Point	5.5"
3-668	1 x 2 Teeth	6.0"
3-670	1 x 2 Teeth	8.0"
3-672	1 x 2 Teeth	10.0"
3-674	1 x 2 Teeth	12.0"
3-676	2 x 3 Teeth	5.0"
3-678	2 x 3 Teeth	5.5"
3-680	2 x 3 Teeth	6.0"
3-682	3 x 4 Teeth	5.0"
3-684	3 x 4 Teeth	5.5"
3-686	3 x 4 Teeth	6.0"
3-687	3 x 4 Teeth	8.0"
3-688	4 x 5 Teeth	5.0"
3-690	4 x 5 Teeth	5.5"
3-692	4 x 5 Teeth	6.0"
3-693	3 x 4 Teeth	10.0"
3-694	3 x 4 Teeth	12.0"
3-695	4 x 5 Teeth	12.0"
3-696	4 x 5 Teeth	10.0"

### • Medium

CAT NO.	TEETH	SIZE
33-660	1 x 2 Teeth	4.5"
33-662	1 x 2 Teeth	5.0"
33-664	1 x 2 Teeth	5.5"
33-666	1 x 2 Teeth, Fine Point	5.5"
33-668	1 x 2 Teeth	6.0"
33-669	1 x 2 Teeth	7.0"
33-670	1 x 2 Teeth	8.0"
33-672	1 x 2 Teeth	10.0"
33-674	1 x 2 Teeth	12.0"
33-675	2 x 3 Teeth	4.5"
33-676	2 x 3 Teeth	5.0"
33-678	2 x 3 Teeth	5.5"
33-680	2 x 3 Teeth	6.0"
33-682	3 x 4 Teeth	5.0"
33-684	3 x 4 Teeth	5.5"
33-686	3 x 4 Teeth	6.0"
33-687	3 x 4 Teeth	8.0"
33-688	4 x 5 Teeth	5.0"
33-690	4 x 5 Teeth	5.5"

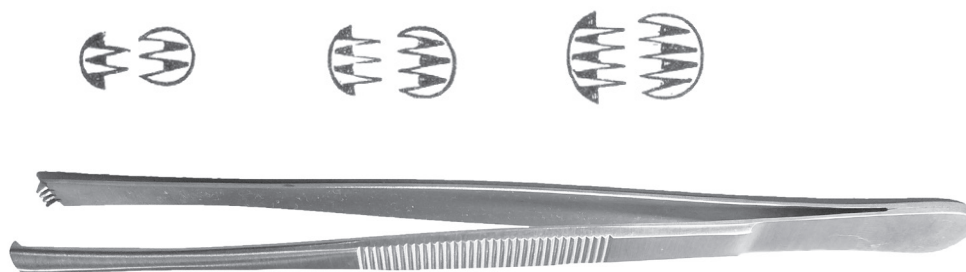

**WE MAINTAIN STOCK LEVEL FOR MOST ITEMS**

## TISSUE FORCEPS

- Stainless Steel
- Premium

CAT NO.	TEETH	SIZE
333-660	1 x 2 Teeth	4.5"
333-662	1 x 2 Teeth	5.0"
333-664	1 x 2 Teeth	5.5"
333-666	1 x 2 Teeth	5.5"
333-668	1 x 2 Teeth	6.0"
333-670	1 x 2 Teeth	8.0"
333-672	1 x 2 Teeth	10.0"
333-674	1 x 2 Teeth	12.0"
333-675	2 x 3 Teeth	4.5"
333-676	2 x 3 Teeth	5.0"
333-678	2 x 3 Teeth	5.5"
333-680	3 x 4 Teeth	6.0"
333-682	2 x 3 Teeth	5.0"
333-684	3 x 4 Teeth	5.5"
333-686	3 x 4 Teeth	6.0"
333-688	4 x 5 Teeth	5.0"
333-690	4 x 5 Teeth	5.5"
333-692	4 x 5 Teeth	6.0"

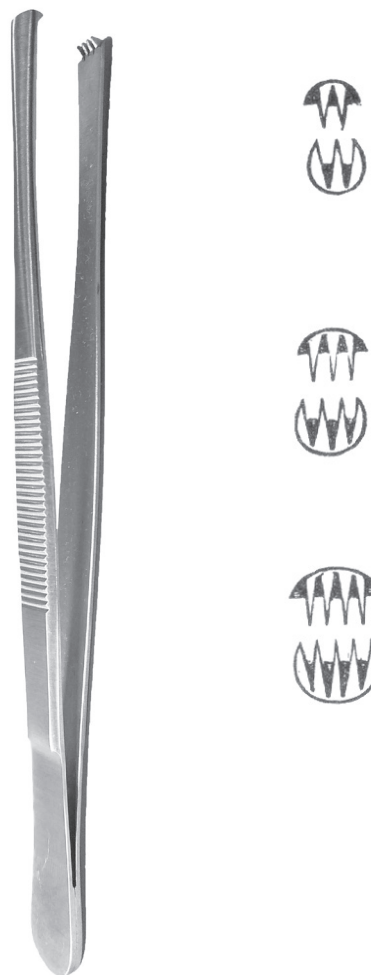

**DON'T SEE AN INSTRUMENT YOU ARE LOOKING FOR?  
WE WILL SOURCE IT FOR YOU**

## BROAD POINT THUMB/DRESSING FORCEPS

- Stainless Steel, Finely Serrated Tips, Broad Serrations on Handle

- **Standard**

CAT NO.	DESCRIPTION	SIZE
3-740	Serrated	3.5"
3-742	Serrated	4.5"
3-744	Serrated	5.0"
3-746	Serrated	5.5"
3-748	Serrated	6.0"
3-750	Serrated	6.0"
3-752	Serrated	8.0"
3-754	Serrated	10.0"
3-756	Serrated	12.0"

- **Medium**

CAT NO.	DESCRIPTION	SIZE
33-742	Serrated	4.5"
33-744	Serrated	5.0"
33-746	Serrated	5.5"
33-748	Serrated	6.0"
33-752	Serrated	8.0"
33-754	Serrated	10.0"
33-756	Serrated	12.0"

- **Premium**

CAT NO.	DESCRIPTION	SIZE
333-741	Serrated	4.0"
333-742	Serrated	4.5"
333-744	Serrated	5.0"
333-746	Serrated	5.5"
333-748	Serrated	6.0"
333-750	Serrated	7.0"
333-752	Serrated	8.0"
333-754	Serrated	10.0"
333-756	Serrated	12.0"



**WE MAINTAIN STOCK LEVEL FOR MOST ITEMS**



## BROWN TISSUE FORCEPS

- Stainless Steel, Side Grasping, 8 x 8 Teeth

- **Standard**

CAT NO.	SIZE
3-710	6.0"

- **Premium**

CAT NO.	SIZE
333-710	6.0"
333-712	8.0"
333-714	10.0"



## BROWN ADSON TISSUE FORCEPS

- Stainless Steel, Side Grasping

- **Standard**

CAT NO.	TEETH	SIZE
3-1600	7 x 7 Teeth	4.75"



## GERALD TISSUE FORCEPS

- Stainless Steel, Straight, 7"

- **Standard**

CAT NO.	TEETH	SIZE
3-1700	1 x 2 Teeth	7"



- **Premium**

CAT NO.	TEETH	SIZE
333-1700	1 x 2 Teeth	7"



**DON'T SEE AN INSTRUMENT YOU ARE LOOKING FOR?  
WE WILL SOURCE IT FOR YOU**



**SPECIMEN/BOTTLE FORCEPS**

- Stainless Steel, Serrated Tips
- **Standard**

CAT NO.	SIZE
3-620	8.0"
3-622	12.0"

**MARTIN TISSUE FORCEPS**

- Stainless Steel, 7 x 8 Teeth
- **Standard**

CAT NO.	SIZE
3-1800	6.0"



- **Premium**

CAT NO.	SIZE
333-1800	6.0"

**CILIA THUMB FORCEPS**

- Stainless Steel, Precise Diagonal Jaws, Flat and Angled, 3.0 mm Wide
- **Premium**

CAT NO.	SIZE
333-2100	3.75"



**WE MAINTAIN STOCK LEVEL FOR MOST ITEMS**

## FOERSTER IRIS TISSUE FORCEPS

- Stainless Steel, Octagonal Grip, 0.5 mm Wide

- Medium**

CAT NO.	DESCRIPTION	SIZE
33-2000	Straight, 1 x 2 Teeth	4.0"
33-2002	Half Curve, 1 x 2 Teeth	4.0"
33-2004	Full Curve, 1 x 2 Teeth	4.0"



## RUSSIAN TISSUE FORCEPS

- Stainless Steel, Circular, Serrated Tips

- Standard**

CAT NO.	SIZE
3-760	6.0"
3-762	8.0"
3-764	10.0"

- Medium**

CAT NO.	SIZE
33-760	6.0"
33-762	8.0"
33-764	10.0"

- Premium**

CAT NO.	SIZE
333-760	6.0"
333-762	8.0"
333-764	10.0"



## SPECIMEN PADDLE FORCEPS

- Stainless Steel, Serrated Pads

- Standard**

CAT NO.	SIZE
33-1045	6.5", 22 mm x 22 mm

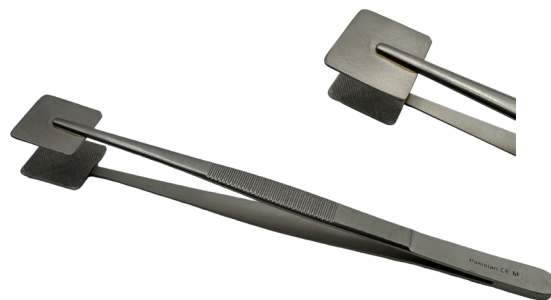

**BAYONET THUMB FORCEPS JANSEN-GRUENWALD**

- Stainless Steel, Serrated Tips

- **Standard**

CAT NO.	DESCRIPTION	SIZE
3-2204	Serrated	8.0"

- **Premium**

CAT NO.	DESCRIPTION	SIZE
333-2200	Extra Delicate Pattern 2mm Wide Serrated Tips	6.25"
333-2202	Serrated	6.5"

**THUMB FORCEPS with MAGNIFIER**

- For Microdissecting, Includes Case

- **Standard**

CAT NO.	SIZE
3-2300	3.5"

- **Premium**

CAT NO.	SIZE
333-2302	3.0"

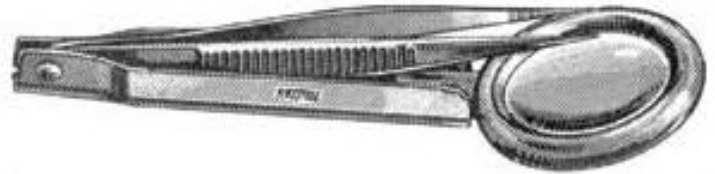
**COVERGLASS FORCEPS**

- Stainless Steel, Straight, Smooth Thin Points, 4.5"

- **Standard**

CAT NO.	SIZE
3-2850	4.5"

**KUHNE COVERGLASS FORCEPS**

- Stainless Steel, Angled Flat Tips, 4.0" (102.0 mm)

- **Standard**

CAT NO.	SIZE
3-2800	4.0"



## ADSON TISSUE FORCEPS

- Stainless Steel, 1 x 2 Teeth

- Standard**

CAT NO.	SIZE
3-362	4.75"

- Medium**

CAT NO.	SIZE
33-362	4.75"

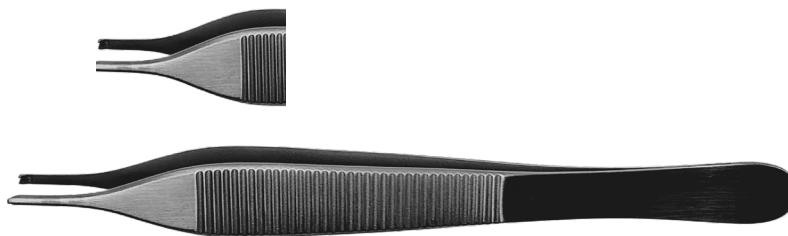

## ADSON DRESSING FORCEPS

- Stainless Steel, Serrated Tips

- Standard**

CAT NO.	SIZE
3-360	4.75"

- Medium**

CAT NO.	SIZE
33-360	4.75"



## GERALD DRESSING FORCEPS

- Stainless Steel, Serrated Tips

- Standard**

CAT NO.	SIZE
3-2600	7.0"

- Premium**

CAT NO.	SIZE
333-2600	7.0"



## ALLIS TISSUE FORCEPS

- Stainless Steel, Straight

- Standard**

CAT NO.	TEETH	SIZE
3-8100	4 x 5 Teeth	6.0"
3-8102	5 x 6 Teeth	6.0"
3-8104	5 x 6 Teeth	7.5"

- Medium**

CAT NO.	TEETH	SIZE
33-8100	4 x 5 Teeth	6.0"
33-8102	5 x 6 Teeth	6.0"
33-8104	5 x 6 Teeth	7.5"



## DURA STRIP FORCEPS

- Stainless Steel, Heavy Gauge Serrated Tips, Box Lock, 8.5" (21.6 cm) Polished

- Standard**

CAT NO.	SIZE
8-226	8.5"



## DRESSING FORCEPS, POTTS-SMITH

- Stainless Steel, Serrated

- Premium**

CAT NO.	DESCRIPTION	SIZE
333-2500	As Pictured	7.00"
333-2502	As Pictured	8.25"
333-2504	As Pictured	9.50"
333-2506	As Pictured	12.00"
333-2508	1 x 2 Teeth	7.00"
333-2510	1 x 2 Teeth	8.25"
333-2512	1 x 2 Teeth	9.50"



## BALLENGER SPONGE FORCEPS

- Stainless Steel, 7" Length

- Standard**

CAT NO.	DESCRIPTION
3-2900	Straight, Serrated
3-2902	Curved, Serrated
3-2904	Straight, Smooth
3-2906	Curved, Smooth

- Medium**

CAT NO.	DESCRIPTION
33-2900	Straight, Serrated
33-2902	Curved, Serrated
33-2904	Straight, Smooth
33-2906	Curved, Smooth



## HALSTEAD'S MOSQUITO FORCEPS

- Stainless Steel

- **Standard**

CAT NO.	DESCRIPTION	SIZE
3-801	Straight	4.5"
3-800	Straight	5.0"
3-803	Curved	4.5"
3-802	Curved	5.0"

- **Medium**

CAT NO.	DESCRIPTION	SIZE
33-800	Straight	5.0"
33-802	Curved	5.0"

- **Premium**

CAT NO.	DESCRIPTION	SIZE
333-800	Straight	5.0"
333-802	Curved	5.0"



## KELLY'S FORCEPS

- Stainless Steel, 5.5"

- **Standard**

CAT NO.	DESCRIPTION	SIZE
3-790	Straight	5.5"
3-792	Curved	5.5"

- **Medium**

CAT NO.	DESCRIPTION	SIZE
33-790	Straight	5.5"
33-792	Curved	5.5"

- **Premium**

CAT NO.	DESCRIPTION	SIZE
333-790	Straight	5.5"
333-792	Curved	5.5"



**DRESSING FORCEPS with GUIDE PIN**

- Stainless Steel, Fine Points, 1 x 2 Teeth

- **Standard**

CAT NO.	SIZE
3-2400	5.5"
3-2402	6.5"
3-2404	8.0"

**ANGULAR JAW FORCEPS**

- Stainless Steel, Fine Points with Guide Pin, 8.0"

- **Standard**

CAT NO.	SIZE
3-3400	8.0"

**FOERSTER DRESSING FORCEPS**

- Stainless Steel, Octagonal Grip, 0.5 mm Wide, 3.75" Length

- **Standard**

CAT NO.	SIZE
333-2700	Straight, Serrated
333-2702	Straight, Serrated
333-2704	Curved, Serrated
333-2706	Curved, Serrated





## BLUMENTHAL RONGEUR

- Stainless Steel, 6" Length

- **Standard**

CAT NO.	DESCRIPTION
3-4000	Standard 30°
3-4002	Angle 45°
3-4004	Angle 90°



## mini BLUMENTHAL RONGEUR

- Stainless Steel, Delicate, 4.50"

- **Standard**

CAT NO.
3-4102



## FRIEDMAN RONGEUR

- Stainless Steel, Delicate, 5.25"

- **Standard**

CAT NO.
3-4100

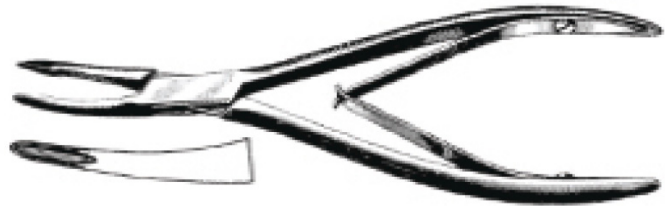

## HARTMAN RONGEUR

- Stainless Steel, 5.75" (14.6 cm), Strong Curve, 4 x 12 mm Bite

- **Premium**

CAT NO.
333-4300



**RONGEUR**

- Stainless Steel

- **Standard**

CAT NO.	DESCRIPTION	SIZE
3-4200	No. 4	5.5"
3-4202	No. 4A	6.5"
3-4204	No. 10 (1A)	6.5"

**RUSKIN RONGEUR**

- Stainless Steel

- **Standard**

CAT NO.	DESCRIPTION	SIZE
333-4504	(18.4 cm) Long, 7 mm Bite	7.25"

- **Premium**

CAT NO.	DESCRIPTION	SIZE
333-4500	(15.2 cm) Long, 3 mm Bite	6"
333-4502	(18.4 cm) Long, 5 mm Bite	7.25"
333-4504	(18.4 cm) Long, 7 mm Bite	7.25"
Available STRAIGHT or CURVED		

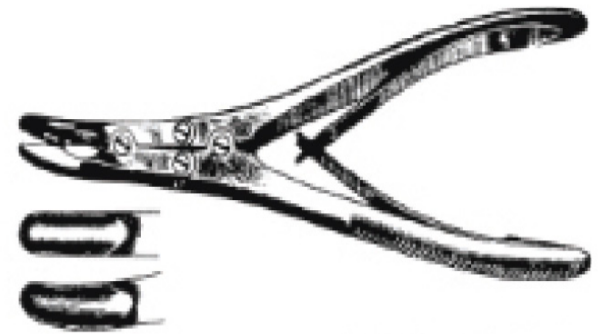
**SIDE CUTTING RONGEUR**

- Stainless Steel

- **Standard**

CAT NO.	DESCRIPTION	SIZE
3-4400	No. 5S	5.75"
3-4402	No. 5	6.50"



## BONE SAW

- Stainless Steel, 8.5" Blade with Rounded Point, 12" Length

- **Standard**

<b>CAT NO.</b>
----------------

3-500
-------



## SATTERLEE'S BONE SAW

- Stainless Steel, 8.5" Blade, 12" Length

- **Standard**

<b>CAT NO.</b>
----------------

3-490
-------



## BRUN'S METACARPAL SAW

- Stainless Steel, 4.5" Blade, 9.5" Length

- **Standard**

<b>CAT NO.</b>
----------------

3-510
-------



## LANGENBECK METACARPAL SAW

- Chrome, 4.5" Blade, 9.25" Length

- **Medium**

<b>CAT NO.</b>
----------------

33-512
--------

- **Premium**

<b>CAT NO.</b>
----------------

333-512
---------



**DON'T SEE AN INSTRUMENT YOU ARE LOOKING FOR?  
WE WILL SOURCE IT FOR YOU**

**GIGLI HANDLES and WIRE SAW**

- Stainless Steel



#3-391



#3-392

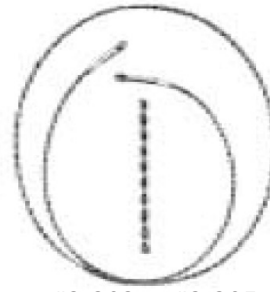

#3-393 to #3-395

- **Standard**

CAT NO.	DESCRIPTION	SIZE
3-391	Handles, Loop, Turnable	3.5"
*Set of Two*		
3-392	Handles, Solid Type	2.0"
*Set of Two*		
3-393	Gigli Wire Saw	12.0"
3-394	Gigli Wire Saw	20.0"
3-395	Gigli Wire Saw	30.0"

**RIB CUTTING KNIFE**

- **Standard**

CAT NO.	DESCRIPTION
3-516	40 mm Cutting Edge, 200 mm
3-518	25 mm Cutting Edge, 200 mm

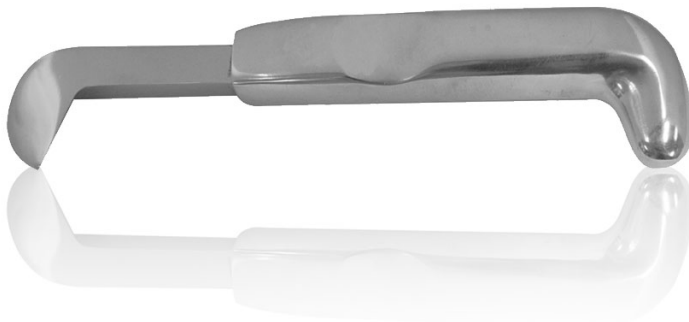

**CALL US FOR ANY INSTRUMENT YOU DON'T SEE HERE**

## RACHIOTOME

- Stainless Steel, 1 1/2" Wide, Cutting Edge 30 mm, 6" Long

- **Standard**

<b>CAT NO.</b>
3-470



## PICK'S MYELOTOME

- Stainless Steel, 30 mm Scraping Edge, 9"

- **Standard**

<b>CAT NO.</b>
3-3520



## COSTOME, 8"

- Stainless Steel

- **Standard**

<b>CAT NO.</b>
3-3540



**DON'T SEE AN INSTRUMENT YOU ARE LOOKING FOR?  
WE WILL SOURCE IT FOR YOU**

## VIRCHOW SKULL BREAKER

- Stainless Steel, 5/8" Wide, Heavy Pattern, 3.5" Long
- **Standard**

CAT NO.
8-224



## JAW SPREADER

- Stainless Steel, Prong Spreader, with Spring Action for One-Hand Operation, 9" Long
- **Standard**

CAT NO.
3-3500



**CALL US FOR ANY INSTRUMENT YOU DON'T SEE HERE**

## PLAIN BONE SHEARS

- Stainless Steel, 2" Jaws, Screw Lock, 9"

- **Standard**

<b>CAT NO.</b>
----------------

3-260
-------

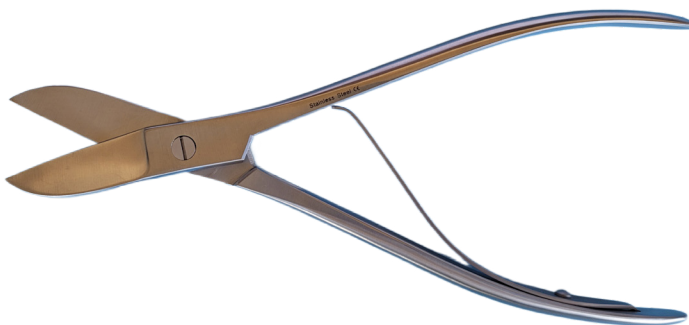

## COUNCILMAN RIB SHEARS

- Stainless Steel, Box Lock, 15" (38.1 cm)

- **Standard**

<b>CAT NO.</b>
----------------

3-230
-------



## CONSTABLE RIB SHEARS

- Stainless Steel, 2" Long Cutting Jaws, Overall 9", Very Sturdy Pattern

- **Standard**

<b>CAT NO.</b>
----------------

3-235
-------

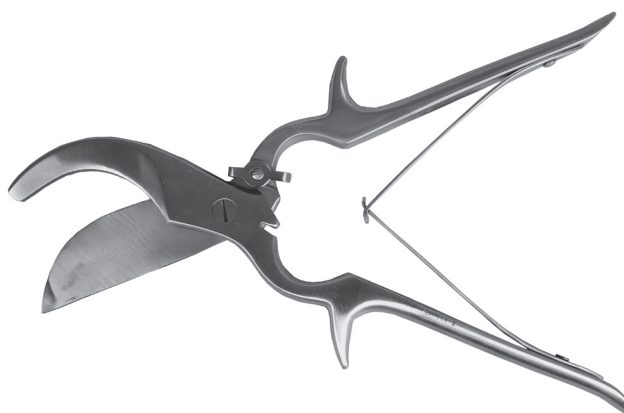

**DON'T SEE AN INSTRUMENT YOU ARE LOOKING FOR?  
WE WILL SOURCE IT FOR YOU**



**GLUCK RIB SHEARS**

- Stainless Steel, Plain Curved, Semi-Box Eccentric Lock, 8.5"

- **Standard**

CAT NO.
3-240

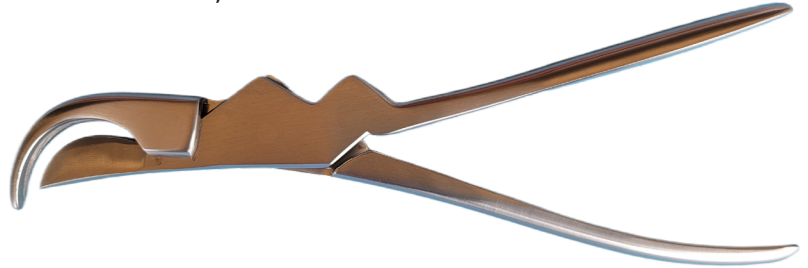
**RIB SHEARS**

- Stainless Steel, Plain Curved, Screw Lock, 9.5"

- **Standard**

CAT NO.
3-245

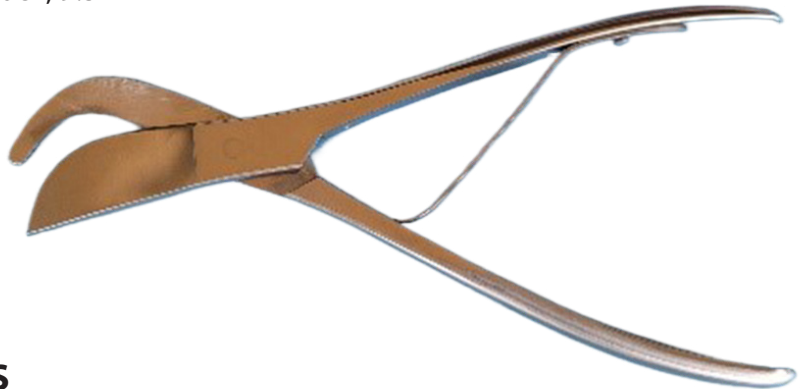
**LISTON BONE CUTTING FORCEPS**

- Stainless Steel

- **Standard, STRAIGHT, Box Lock.**

CAT NO.	SIZE
3-270	5.5"
3-280	7.5"

- **Standard, STRAIGHT, Screw Lock**

CAT NO.	SIZE
3-300	7.5"
3-302	10.0"

- **Standard, ANGLED, Box Lock**

CAT NO.	SIZE
3-290	5.5"
3-292	7.5"

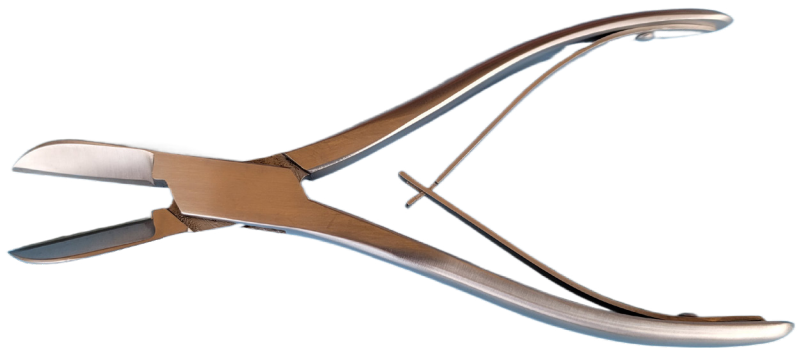

**CALL US FOR ANY INSTRUMENT YOU DON'T SEE HERE**

## SPINAL CORD REMOVAL INSTRUMENT

- "V" SHAPE
- Stainless Steel

Facilitates removing the cord within the cranial cavity without the necessity of removing the spinal processes, laminae and dura. The "V" shaped blades, approximately 1.3 cm in length and 1.5 cm in width, are of hardened stainless steel. Inner edges are sharpened. Outer edges are dull to prevent damage to adjacent areas and spinal cord. Shaft is 0.2 cm in diameter and 78 cm Long. Shaft and handle are permanently attached to the blades.

- **Standard**

CAT NO.
3-880

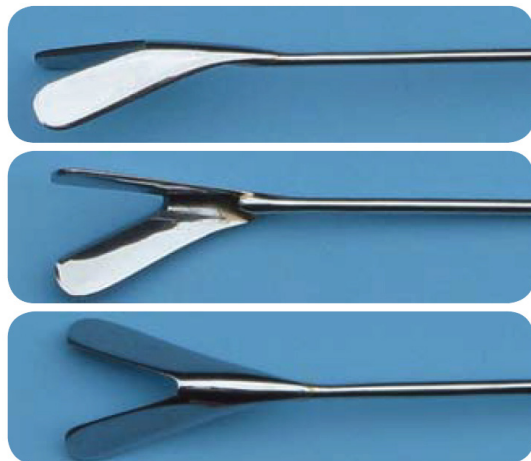

## TEASING NEEDLES

- Stainless Steel, Wood Handles 5.5"

- **Standard**

CAT NO.	DESCRIPTION	SIZE
3-550	Straight Point, 6 / Pack	5.5"
3-552	Angled Point, 6 / Pack	5.5"



**DON'T SEE AN INSTRUMENT YOU ARE LOOKING FOR?  
WE WILL SOURCE IT FOR YOU**

**HAMMER WITH HOOK**

- Stainless Steel, 12 oz., 8.25" Long

- **Standard**

<b>CAT NO.</b>
3-520

**BONE Mallet (LEAD FILLED)**

- Stainless Steel, 18 oz., 70 mm x 35 mm Face, 9.75" Long

- **Standard**

<b>CAT NO.</b>
3-540

**BONE Mallet (STEEL)**

- Stainless Steel, 12 oz., 1 1/8" Face, 9.25" Long

- **Standard**

<b>CAT NO.</b>
3-530



## U.S. ARMY PATTERN OSTEOTOMES

- Stainless Steel, 6.5" Long

- **Standard**

CAT NO.	CUTTING EDGE
3-420	6 mm
3-422	12 mm
3-424	18 mm



## LAMBOTTE'S OSTEOTOME

- Stainless Steel, Thin Pattern, 9" Long, 1/8" (3 mm) Thick

- **Standard**

CAT NO.	CUTTING EDGE
3-430	1/2" (13.0 mm)
3-432	1" (25.0 mm)



## HOKE OSTEOTOME

- Stainless Steel, 5.5" Long

- **Premium**

CAT NO.	CUTTING EDGE
333-400	3 mm, 1/8"
333-402	5 mm, 3/16"
333-404	7 mm, 1/4"
333-406	8.5 mm, 5/16"
333-408	10 mm, 3/8"
333-409	12 mm, 1/2"



## KERN BONE HOLDING FORCEPS

- Chrome, 4.5" Blade

- **Standard, KERN**

CAT NO.	CUTTING EDGE
3-203	6", Plain (Pediatric)
3-204	9.5", Plain
3-205	6", With Ratchet (Pediatric)
3-206	9.5", With Ratchet

- **Standard, LEWIN**

CAT NO.	CUTTING EDGE
3-207	7", Plain, Serrated Jaws



**U.S. ARMY PATTERN CHISEL**

- Stainless Steel, 6.5" Long

- **Standard**

CAT NO.	CUTTING EDGE	LENGTH
3-450	6 mm	6.5"
3-452	12 mm	6.5"
3-454	18 mm	6.5"

- **Premium**

CAT NO.	CUTTING EDGE	LENGTH
333-420	6 mm	6.5"
333-422	12 mm	6.5"
333-424	18 mm	6.5"

**BRUNETTI'S CHISEL with GUARD**

- Stainless Steel, 11.25" Long, For Opening Spinal Column, Left or Right

- **Standard**

CAT NO.	DESCRIPTION
3-460	Right
3-462	Left

**COUNCILMAN'S CHISEL**

- Stainless Steel, Hatchet Shape, 6.75" Long, 2" Cutting Edge

- **Standard**

CAT NO.	CUTTING EDGE
3-480	2" Cutting Edge

**U.S. ARMY PATTERN GOUGE**

- Stainless Steel

- **Premium**

CAT NO.	CUTTING EDGE	LENGTH
333-410	6 mm	6.5" Long
333-412	12 mm	6.5" Long



## ENGLISH PATTERN TUBE OCCLUDING CLAMP

- Stainless Steel
- **Standard**

CAT NO.	DESCRIPTION	SIZE
3-3700	Angled, Smooth	4.5"
3-3702	Straight, Smooth	4.5"
3-3704	Straight, Smooth, Heavy Pattern	7.0"

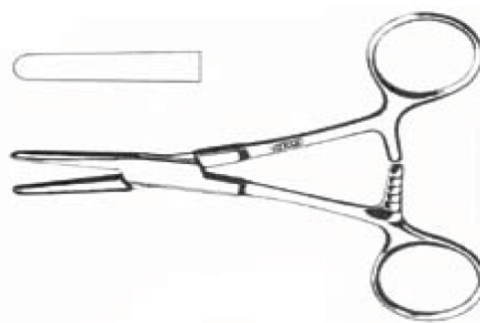

## ST. VINCENT'S TUBE OCCLUDING CLAMPS

- Stainless Steel, Smooth Jaws
- **Standard**

CAT NO.	DESCRIPTION	LENGHT
3-3730	Straight	6.5"
3-3732	Curved	6.5"



## PRESBYTERIAN TUBE OCCLUDING CLAMP

- Stainless Steel, Straight Smooth, 6.5" Long
- **Standard**

CAT NO.
3-3720

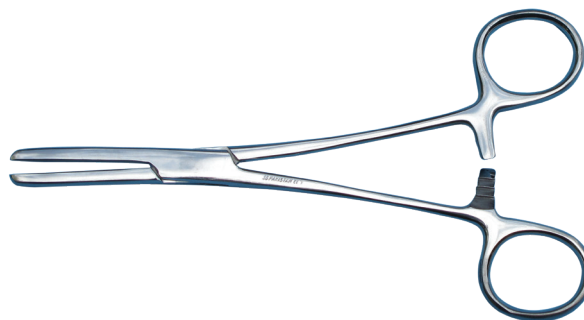

## TUBE OCCLUDING CLAMPS

- Stainless Steel, Semi-Box Eccentric Lock
- **Standard**

CAT NO.	DESCRIPTION	SIZE
3-3740	Straight, Smooth	5.5"
3-3742	Straight, Smooth	7.0"
3-3744	With Guard, Smooth	7.0"
3-3746	Straight Flat, Serrated	7.0"



**FLESH HOOK**

- Stainless Steel, Two Prongs on Each Side, 2.25"

- **Standard**

CAT NO.
---------

3-3900
--------

**TRIPLE CHAIN HOOK, 6"**

- Stainless Steel

- **Standard**

CAT NO.
---------

3-3910
--------

**GILLIES SKIN HOOK**

- Stainless Steel, Straight

- **Standard**

CAT NO.	DESCRIPTION	LENGHT
3-3920	Small	7"
3-3922	Large	7"





## ALLIS DRY DISSECTOR

- Stainless Steel, Used As An Elevator to Raise Tissue. Useful As a Dissecting Probe.
- Will Not Cut Tissue

- **Standard**

CAT NO.
3-850



## DISSECTING TENACULUM

- Stainless Steel, For Lifting Tissue With a Very Sharp Point, 6.5"

- **Standard**

CAT NO.
3-830



## ANEURYSM NEEDLE (BROAD HANDLE)

- Stainless Steel
- The Broad Flat Handle With Its Thumb Groove Makes It Ideal For Use With Rubber Gloves. A Standard Flat Blade With Large Thread Eye And Short Curved Hook For Vein Elevating.

- **Premium**

CAT NO.
3-860



## PROBES

- Stainless Steel

- **Standard**

CAT NO.	DESCRIPTION
3-559	4.5" Double Ended, Flexible
3-560	5.0" Double Ended, Flexible
3-561	5.5" Double Ended, Flexible
3-562	6.0" Double Ended, Flexible
3-564	8.0" Double Ended, Flexible
3-565	4.5" with Eye, Flexible
3-566	5.0" with Eye, Flexible
3-567	5.5" with Eye, Flexible
3-568	6.0" with Eye, Flexible
3-570	8.0" with Eye, Flexible
3-572	10.0" with Eye, Flexible
3-574	12.0" with Eye, Flexible



## GROOVED DIRECTOR

- Stainless Steel

- **Standard**

CAT NO.	DESCRIPTION
3-580	4.5" Plain End, Tongue Tie
3-582	5.0" Plain End, Tongue Tie
3-583	5.5" Plain End, Tongue Tie
3-584	6.0" Plain End, Tongue Tie
3-586	4.5" Probe End, Tongue Tie
3-588	5.0" Probe End, Tongue Tie
3-589	5.5" Probe End, Tongue Tie
3-590	6.0" Probe End, Tongue Tie

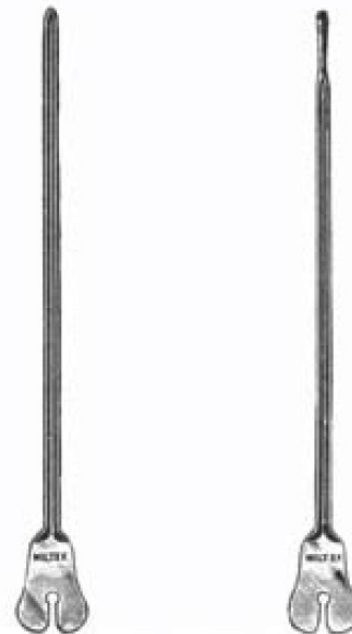

**WE MAINTAIN STOCK LEVEL FOR MOST ITEMS**

## BULLET PROBES

- Precision Stainless Steel
- Ideal for tracing entry of bullet angle and path. Ultra Smooth Finish, Ball- End, Round Tip

- Available In 3 Sizes

CAT NO.	DESCRIPTION
3-592	18" Long, 22 Caliber
3-593	18" Long, 38 Caliber
3-594	18" Long, 45 Caliber
3-596	24" long, 38 Caliber
3-598	36" long, 38 Caliber

**VOLUME DISCOUNTS AVAILABLE**

**PLEASE CALL  
(949) 699-3663  
FOR FURTHER DETAILS**

**22 Caliber**



**38 Caliber**



**45 Caliber**



**ANEURYSM NEEDLE**

- Stainless Steel, 6 1/2", Pulls Needle Through Tough Tissue, Blunt Tip with Eye

- **Medium**

CAT NO.
33-840

- **Premium**

CAT NO.
333-840

**MICROTOME OBJECT DISC**

- Stainless Steel

- **Standard**

CAT NO.	SIZE
3-820	7/8"
3-822	1 1/8"
3-824	1 1/2"
3-826	2"



**DONT' SEE WHAT YOU ARE LOOKING FOR?  
WE WILL SOURCE IT FOR YOU**

## US ARMY RETRACTORS

- Stainless Steel, Set of two

- **Standard**

CAT NO.
---------

3-6500
--------



## SENN (MILLER) RETRACTOR

- Stainless Steel, 6.25", Double Ended

- **Standard**

CAT NO.	DESCRIPTION
3-6600	Sharp
3-6602	Blunt

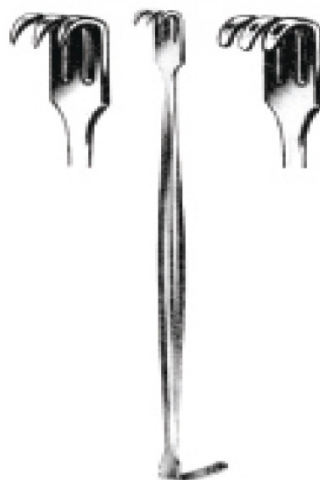

## TRACHEAL RETRACTORS

- Stainless Steel, Rigid Neck, 6"

- **Standard**

CAT NO.	DESCRIPTION
3-6300	1 Prong, Sharp
3-6302	2 Prongs, Sharp
3-6304	3 Prongs, Sharp
3-6306	1 Prong, Blunt
3-6308	2 Prongs, Blunt
3-6310	3 Prongs, Blunt



**WE MAINTAIN STOCK LEVEL FOR MOST ITEMS**

## WEITLANER RETRACTORS

- Stainless Steel

- **Standard**

CAT NO.	DESCRIPTION	SIZE
3-6000	(10.2 cm) 2 x 3 Teeth, Sharp	4.0"
3-6002	(14 cm) 3 x 4 Teeth, Sharp	5.5"
3-6004	(16.5 cm) 3 x 4 Teeth, Sharp	6.5"
3-6006	(20.3 cm) 3 x 4 Teeth, Sharp	8.0"
3-6008	(10.2 cm) 2 x 3 Teeth, Blunt	4.0"
3-6010	(14 cm) 3 x 4 Teeth, Blunt	5.5"
3-6012	(16.5 cm) 3 x 4 Teeth, Blunt	6.5"
3-6014	(20.3 cm) 3 x 4 Teeth, Blunt	8.0"



- **Premium**

CAT NO.	DESCRIPTION	SIZE
333-6000	(10.2 cm) 2 x 3 Teeth, Sharp	4.0"
333-6002	(14 cm) 3 x 4 Teeth, Sharp	5.5"
333-6004	(16.5 cm) 3 x 4 Teeth, Sharp	6.5"
333-6006	(20.3 cm) 3 x 4 Teeth, Sharp	8.0"
333-6007	(24.1 cm) 3 x 4 Teeth, Sharp	9.5"
333-6008	(10.2 cm) 2 x 3 Teeth, Blunt	4.0"
333-6010	(14 cm) 3 x 4 Teeth, Blunt	5.5"
333-6012	(16.5 cm) 3 x 4 Teeth, Blunt	6.5"
333-6014	(20.3 cm) 3 x 4 Teeth, Blunt	8.0"
333-6015	(24.1 cm) 3 x 4 Teeth, Blunt	9.5"

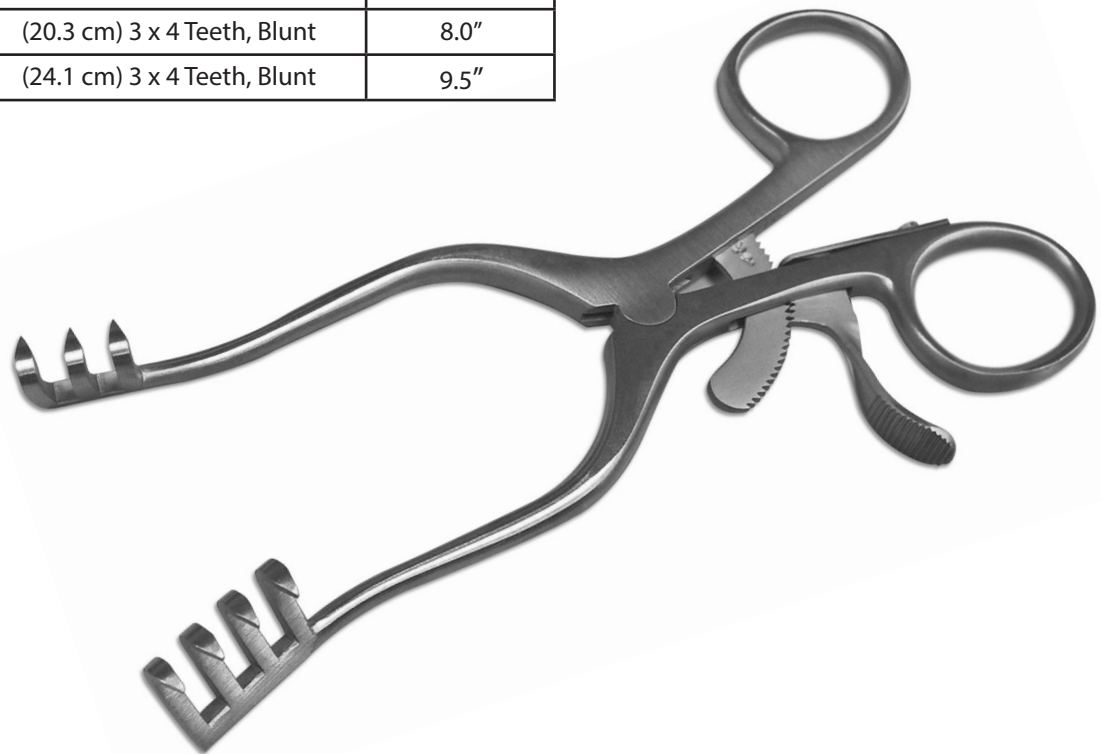

## RICHARDSON - EASTMAN RETRACTORS

- Stainless Steel, Double Ended

- **Standard**

CAT NO.	DESCRIPTION	SIZE
3-6102	Small Size	10.0"
3-6104	Large Size	11.0"

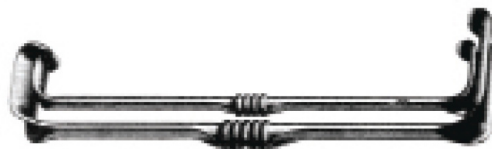

## RICHARDSON RETRACTORS, HOLLOW GRIP HANDLE

- Stainless Steel, 9.5", Hollow Grip Handle

- **Standard**

CAT NO.	HANDLE SIZE
3-6200	1" x 3/4"
3-6202	1 1/4" x 1"
3-6204	1 1/2" x 1 1/2"
3-6206	2" x 3/4"



## DEAVER RETRACTORS

- Stainless Steel

- **Standard**

CAT NO.	SIZE
3-6400	1" x 9"
3-6402	1" x 12"
3-6404	1" x 13"
3-6406	1 1/2" x 12"
3-6408	2" x 12"
3-6410	3" x 12"



**VOLUME DISCOUNTS AND CONTRACT PRICING AVAILABLE**



## INSTRUCTOR'S DISSECTING KIT

### Standard CAT NO. 3 - 5100

- Soft Case
- Needle, Straight, Blunt
- Dressing Forcep, Serrated, 5 ½"
- Scalpels, Small
- Dissecting Scissors, 4 ½"
- Scalpels, Large
- O.R. Scissors, Straight, S/B, 5 ½"
- Dropper
- Tissue Forcep, 1 x 2T, 5 ½" Ruler
- Tissue Forcep, 1 x 2T, 5 ½"
- Triple Chain Hooks
- Spatula, Double Ended
- Needle, Straight, Sharp



**KITS CAN BE CUSTOMIZED TO YOUR NEEDS**

**DONT' SEE WHAT YOU ARE LOOKING FOR?**

**WE WILL SOURCE IT FOR YOU**

## STUDENT DISSECTING KIT

### Standard CAT NO. 3 - 5105

- Soft Case
- Knife Handle, #3
- MAYO HEGAR Needle Holder, 6"
- Knife Handle, #4
- Dressing Forcep, Serrated, 5.5"
- Teasing Needle, Angled
- Tissue Forceps, 1x2T, 5 ½ Ruler
- Triple Chain Hook
- O.R. Scissors, Straight, S/B, 5 ½"
- Dropper
- KELLY Hemostatic Forceps Str, 5 ½"
- Proble with Eye, 5 ½"
- Grooved Director, Plain End, 5 ½"



**KITS CAN BE CUSTOMIZED TO YOUR NEEDS**

**VOLUME DISCOUNTS AND CONTRACT PRICING AVAILABLE**

## MEASURING TAPE

The blade positively locks in position until the cam-activated lock button is released.

CAT NO.	DESCRIPTION
12-3940	1/2"/12 mm x 12' / 4m
12-3942	3/4"/19 mm x 16' / 5m



### FEATURES

- Yellow Measuring Blades
- Tough Tip Blade Protector standard on all 1" and 3/4" (25 and 19 mm) blades (except Re-Tape)
- Rugged, impact resistant case
- Lower edge is graduated in millimeters & numbered in consecutive millimeters to each decimeter & repeat
- Top edge graduated in 16th of an inch and numbered in consecutive inches and numbered at each foot

## POCKET CALIPER

- 5" rule with inside and outside readings in 16ths and 32nds
- Decimal equivalents on back

CAT NO.
12-3950

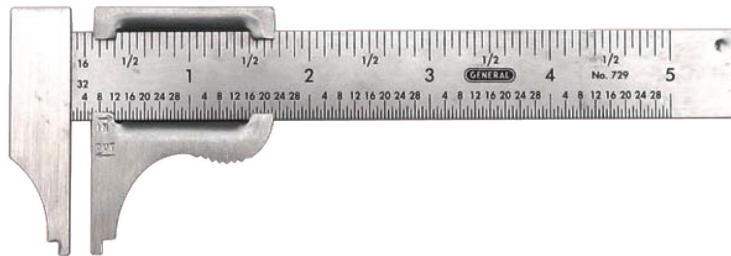

## JAMESON CALIPER

- Made of chrome with thin tips, 3 3/4" (9.5 cm)
- Graduated in inches and mm

CAT NO.
12-3952



**WE MAINTAIN STOCK LEVEL FOR MOST ITEMS**

## FLEXIBLE STEEL RULERS

Satin Chrome Finish

Metric Reading Graduation: E/M = 32nds, 64ths, 1/2 mm, 1 mm;  
4R = 8ths, 16ths, 32nds and 64ths

### FEATURES

- Made of hardened and tempered stainless steel
- Graduations are Marked Micro-Fine on Non-Glare
- Rust and wear resistant to extraordinary durability

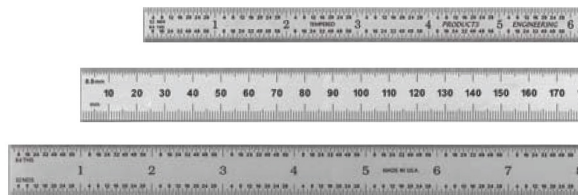

CAT NO.	SIZE	GRADUATION	WIDTH
12-3900	6"	E/M	1/2"
12-3902	12"	E/M	1/2"
12-3904	18"	E/M	3/4"
12-3906	24"	E/M	3/4"
12-3908	36"	E/M	3/4"
12-3910	48"	4R	3/4"

## ECONOMY FLEXIBLE STEEL RULER

6" (15.2cm) x 1/2" (1.3cm), graduated in 1/32" (0.8mm) fractions and mm.  
Flexible stainless steel.

<b>CAT NO.</b>
12-3912



## THE GOLDEN RULE

### FEATURES

- Titanium-Coated for Exceptional Wear & Visibility.
- Long Lasting, hard-wearing, non-glare finish, RC 80 hardness
- Scratch-resistant, microfine graduations with excellent clarity and contrast
- 30% harder than standard chrome rulers

CAT NO.	SIZE	GRADUATION	WIDTH
12-3920	6"/150 mm	Flexible	in/metric
12-3922	12"/300 mm	Flexible	in/metric
12-3924	6"/150 mm	Rigid	in/metric
12-3926	12"/300 mm	Rigid	in/metric





## INSTRUMENT TRAYS

A wide assortment of heavy-duty, seamless trays have coved corners for easy sterilization. Covers have recessed strap handles for ease in handling and storing.

- Stainless Steel

CAT NO.	DIMENSIONS L x W x H	QTs.
22-0600	5 $\frac{3}{8}$ x 4 x 2 $\frac{5}{8}$	5/8
22-0600C	Cover - Fits # 22-0600 Tray	
22-0602	6 $\frac{1}{8}$ x 6 $\frac{1}{8}$ x 2 $\frac{7}{8}$	1 $\frac{1}{4}$
22-0602C	Cover - Fits # 22-0602 Tray	
22-0604	8 $\frac{7}{8}$ x 5 x 2	1
22-0606	8 $\frac{7}{8}$ x 5 x 3	1 $\frac{5}{8}$
22-0604C	Cover - Fits Above 2 Trays	
22-0608	10 x 6 $\frac{1}{2}$ x 2	1 $\frac{5}{8}$
22-0608C	Cover - Fits # 22-0608 Tray	
22-0610	12 $\frac{1}{4}$ x 7 $\frac{3}{4}$ x 2 $\frac{1}{4}$	2 $\frac{7}{8}$
22-0610C	Cover - Fits # 22-0610 Tray	
22-0612	10 x 8 $\frac{1}{4}$ x 2 $\frac{1}{2}$	2 $\frac{5}{8}$
22-0612C	Cover - Fits Above 2 Trays	
22-0616	16 $\frac{1}{2}$ x 10 x 2 $\frac{1}{2}$	5
22-0618	16 $\frac{1}{2}$ x 10 x 4	8 $\frac{7}{8}$
22-0616C	Cover - Fits Above 2 Trays	
2-0620	6 $\frac{7}{8}$ x 4 $\frac{1}{4}$ x 2	5/8
22-0622	6 $\frac{7}{8}$ x 4 $\frac{1}{4}$ x 4	1 $\frac{1}{8}$
22-0620C	Cover - Fits Above 2 Trays	
22-0624	13 $\frac{7}{8}$ x 12 $\frac{7}{8}$ x 2 $\frac{1}{2}$	6 $\frac{1}{8}$
22-0626	13 $\frac{7}{8}$ x 12 $\frac{7}{8}$ x 4	9 $\frac{3}{4}$
22-0628	13 $\frac{7}{8}$ x 12 $\frac{7}{8}$ x 6	14 $\frac{3}{8}$
22-0624C	Cover - Fits Above 3 Trays	
Standard Weight (22 Ga.)		
22-0630	6 $\frac{7}{8}$ x 6 $\frac{3}{8}$ x 2 $\frac{1}{2}$	1
22-0632	6 $\frac{7}{8}$ x 6 $\frac{3}{8}$ x 4	1 $\frac{3}{4}$
22-0634	6 $\frac{7}{8}$ x 6 $\frac{3}{8}$ x 6	2 $\frac{5}{8}$
22-0630C	Cover - Fits Above 3 Trays	

22-0608 and 22-0608C



22-0602 and 22-0602C



22-0626



22-0612



22-0616



## INSTRUMENT TRAYS

A wide assortment of heavy-duty, seamless trays have covered corners for easy sterilization. Covers have recessed strap handles for ease in handling and storing.

- Stainless Steel

CAT NO.	DIMENSIONS L x W x H	QTs.
Standard Weight (22 Ga.)		
22-0700	12 3/4 x 6 7/8 x 2 1/2	2 3/8
22-0702	12 3/4 x 6 7/8 x 4	4
22-0704	12 3/4 x 6 7/8 x 6	6 1/8
Heavy Weight (20 Ga.)		
22-0720	12 3/4 x 6 7/8 x 2 1/2	2 3/8
22-0722	12 3/4 x 6 7/8 x 4	4
22-0724	12 3/4 x 6 7/8 x 6	6 1/8
22-0426C	Cover - Fits Above 6 Trays	
Standard Weight (22 Ga.)		
22-0740	12 3/4 x 10 3/8 x 2 1/2	4
22-0742	12 3/4 x 10 3/8 x 4	7
22-0744	12 3/4 x 10 3/8 x 6	10
Heavy Weight (20 Ga.)		
22-0760	12 3/4 x 10 3/8 x 2 1/2	4
22-0762	12 3/4 x 10 3/8 x 4	7
22-0764	12 3/4 x 10 3/8 x 6	10
22-0766C	Cover - Fits Above 6 Trays	
Standard Weight (22 Ga.)		
22-0780	20 3/4 x 12 3/4 x 2 1/2	9
22-0782	20 3/4 x 12 3/4 x 4	15
22-0784	20 3/4 x 12 3/4 x 6	22
Heavy Weight (20 Ga.)		
22-0800	20 3/4 x 12 3/4 x 2 1/2	9
22-0802	20 3/4 x 12 3/4 x 4	15
22-0804	20 3/4 x 12 3/4 x 6	22
22-0806C	Cover - Fits Above 6 Trays	

## INSTRUMENT TRAYS WITHOUT COVERS

All trays feature flat bottoms, open beads and covered corners.

- Stainless Steel

CAT NO.	DIMENSIONS L x W x H	QTs.
22-1104	w/ Very Slight Flange	8 3/4 x 4 5/8 x 3 1/8
22-1106	w/ Very Slight Flange	10 5/16 x 5 1/2 x 4

22-0702



22-0742

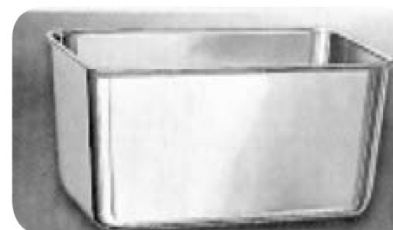

22-0782

*With Very Slight Flange*

**INSTRUMENT DRYING TRAYS**

- The user of these trays benefit from covered corners and large open bead which allow for easy handling, stacking and cleaning.
- Stainless Steel

CAT NO.	DESCRIPTION	DIMENSIONS L x W x H
22-1300	w/ Rolled Bead	10 x 6 1/2 x 3/4
22-1302	w/ Rolled Bead	13 1/16 x 9 13/16 x 3/4
22-1304	w/ Rolled Bead	15 1/8 x 10 5/8 x 3/4
22-1306	w/ Rolled Bead	17 x 1 15/8 x 3/4
22-1308	w/ Rolled Bead	19 1/8 x 12 5/8 x 3/4
22-1310	w/ Rolled Bead	21 1/4 x 16 1/4 x 7/8
22-1312	w/ Flat Flange	25 x 15 x 5/8
22-1314	w/ Flat Flange	12 3/4 x 10 3/8 x 1 1/4
22-1316	w/ Flat Flange	20 3/4 x 12 3/4 x 1 1/4

**STERILIZATION BATH SETS**

- Tray units can be used for either hot or cold sterilization. Covers feature recessed strap handle for ease and safety in transporting, handling and storing.
- Stainless Steel

CAT NO.	DESCRIPTION	DIMENSIONS L x W x H
22-1300	w/ Rolled Bead	10 x 6 1/2 x 3/4
22-0784	Solid Tray	20 3/4 x 12 3/4 x 6
22-0922	Perforated Tray	20 3/4 x 12 3/4 x 4
22-0806C	Flat, Solid Cover	
22-0742	Solid Tray	12 3/4 x 10 3/8 x 4
22-0942	Perforated Tray	12 3/4 x 10 3/8 x 2 1/2
22-0766C	Flat, Solid Cover	
22-0744	Solid Tray	12 3/4 x 10 3/8 x 6
22-0962	Perforated Tray	12 3/4 x 10 3/8 x 4
22-0766C	Flat, Solid Cover	

**STERILIZATION TRAYS (Hot/Cold)**

- All trays feature flat bottoms, open beads and covered corners.
- Stainless Steel

CAT NO.	DESCRIPTION	DIMENSIONS L x W x H
22-1104	w/ Very Slight Flange	8 3/4 x 4 5/8 x 3 1/8
22-1106	w/ Very Slight Flange	10 5/16 x 5 x 4





## PERFORATED CLEANING BASKETS

- The lining of the cleaning baskets boasts 1/4" holes on the bottom and sides to provide excellent penetration of cleaning solutions. Easy-to-clean retractable handles are set on top of basket to promote safe, easy handling. The bottom is offset from the surface by four "feet" to enhance draining and drying. Lids also available.

- Stainless Steel

CAT NO.	DIMENSIONS L x W x H
22-0902	20 3/4 x 12 3/4 x 2 1/2
22-0922	20 3/4 x 12 3/4 x 4
22-1604	20 3/4 x 12 3/4 x 6
22-0942	12 3/4 x 10 3/8 x 2 1/2
22-0962	12 3/4 x 10 3/8 x 4
22-1610	12 3/4 x 10 3/8 x 6



## STAINLESS STEEL SANI-TRAY

- The Perfect Solution for Sanitizing Long Instruments
- Unit may be wall mounted or placed on a counter or shelf
- Hinged Cover
- Has a built in drain for convenient disinfecting solution changes



CAT NO.	DIMENSIONS L x W x H
22-2800	30" x 4" x 4"

## COUNTERTOP TRAY

- The Perfect Solution for Sanitizing Long Instruments
- Tray has a flat bottom and may be placed on counter or shelf
- Constructed of heavy gauge stainless steel, comes complete with lid

CAT NO.	DIMENSIONS L x W x H
22-2810	30" x 4" x 4"



**GRADUATED MEASURES**

- Graduated in ounces and cc's. Measures have easy grip handles and large, smooth pouring spouts.
- Stainless Steel

CAT NO.	CAPACITY	DIMENSIONS DIA. x H (in.)
22-0200	16 Oz.	3 $\frac{3}{4}$ x 4 $\frac{5}{8}$
22-0202	32 Oz.	4 $\frac{3}{4}$ x 5 $\frac{1}{4}$
22-0204	64 Oz.	5 $\frac{1}{2}$ x 6 $\frac{1}{2}$

**IODINE Utility CUPS**

- Stainless Steel

CAT NO.	CAPACITY	DIMENSIONS DIA. x H (in.)
22-1900	6 Oz.	3 $\frac{7}{16}$ x 2
22-1902	14 Oz.	4 $\frac{3}{8}$ x 2 $\frac{5}{8}$

**INSTRUMENT HOLDER**

- Stainless Steel

CAT NO. DIA. x H (in.)	DIMENSIONS DIAMETER	BASE
22-2240	1 x 4	2 $\frac{7}{16}$ "
22-2242	2 $\frac{1}{4}$ " x 4 $\frac{1}{2}$ "	3 $\frac{5}{8}$ "
22-2244	2 $\frac{1}{4}$ " x 7	3 $\frac{1}{16}$ "



## SOLUTION BOWLS

- Tapered sides and rounded bead design make these basins ideal for storing and pouring.
- Stainless Steel

CAT NO.	CAPACITY	DIMENSIONS DIA. x H (in.)
22-1700	3/4 Qt.	6 1/4 x 2 3/8
22-1702	1 1/2 Qt.	8 1/8 x 3
22-1704	3 Qt.	9 3/4 x 4
22-1706	5 Qt.	11 7/8 x 4 1/2
22-1708	6 3/4 Qt.	12 3/4 x 5 1/4
22-1710	8 Qt.	13 5/16 x 5 7/16
22-1712	13 Qt.	16 1/4 x 6



## KICK BUCKET (PAILS) & STAND

- Pails are tapered for easy pouring. "Ears" for handles are an integral part of pail, resisting breakoff, allowing for easy cleaning. Sturdy construction.

\*Stand Fits Sizes 22-2500 / 22-2502

- Stainless Steel Stand Supported by 4 Rubber Casters.

CAT NO.	DESCRIPTION
22-2500	13 Qt. Pail, 11 5/8 x 9 1/4
22-2502	16 Qt. Pail, 11 3/4 x 10 1/8
22-2504	20 Qt. Pail, 13 3/4 x 11 13/16
22-2506	Kick Bucket Stand



**VOLUME DISCOUNTS AND CONTRACT PRICING AVAILABLE**

**COLOR CODED ONE-PIECE LADLES**

- Completely sanitary and seamless, Ladles are constructed from 18-8 304 stainless steel. Extra strength and greater durability. Color Coded.
- Stainless Steel

CAT NO.	COLOR	CAPACITY
22-2602	Black	1 oz.
22-2606	Blue	2 oz.
22-2608	Ivory	3 oz.
22-2610	Gray	4 oz.
22-2612	Teal	6 oz.
22-2614	Orange	8 oz

**LADLES**

- Stainless Steel

CAT NO.	CAPACITY
22-2620	1/2 oz.
22-2622	1 oz.
22-2624	1½ oz.
22-2626	2 oz.
22-2628	3 oz.
22-2630	4 oz.
22-2632	6 Oz.
22-2634	8 Oz.
22-2636	12 Oz.



**DONT' SEE WHAT YOU ARE LOOKING FOR?  
WE WILL SOURCE IT FOR YOU**

## INSTRUMENT CLEANING BRUSH

- Extra firm designed to clean instrument serrations, rasps, files and burs.
- Autoclavable, 7 1/4" (18.4cm).

CAT NO.	DESCRIPTION
333-8000	3/Pack Stainless Steel Bristles
333-8002	3/Pack Nylon Bristles



## LOW -SUDS LIQUID DETERGENT

- Biodegradable, neutral pH cleanser produces minimal suds for ultrasonic / washer-sterilizer cleaning. Economical, highly concentrated detergent acts as a hemolytic (blood remover) and rust inhibitor to help extend instrument life. Contains a rinsing agent for easy, one-step clean-

CAT NO.
62-8020



1 Gallon Bottles, 4/Case

## HIGH -SUDS LIQUID DETERGENT

- For manual instrument cleaning. Hemolytic formula removes blood and soil, rinses spot-free and leaving no residue. Contains a rust inhibitor to prolong instrument life. biodegradable and highly concentrated with a neutral pH. Not for use in automatic washers.

CAT NO.
62-8022



1 Gallon Bottles, 4/Case

## GERMICIDAL DEODORIZERS

- Effectively Kills HIV and HBV in One Minute, TB, Strep, Staph, Pseudomonas, salmonella, herpes simplex, influenza poliovirus, canine parvovirus and vaccinia are killed within Ten Minutes.

CAT NO.
62-8032



Packaged 12 / Case (14oz Cans)

## ROOM DEODORIZERS

- Environmentally Safe - FRESH CITRUS SCENT
- Eliminates harsh odors. 100% Natural so it is Safe to use Everywhere.
- 7oz Spray Bottles.

CAT NO.	DESCRIPTION
62-8028	12/Case 7oz Spray Bottles



**HAMPER STAND with FOOT PEDAL**

- Sturdy, Durable, Chrome Plated Frame.
- Metal, foot pedal operated lid
- 2 locking soft rubber casters
- Vinyl pouch for bag storage, vinyl coated ring to hold bag in place
- Fits 18" Bags or 33 Gallon Disposable Bags

**CAT NO.**

20-9330

**DISPOSABLE SOILED LINEN LINERS**

- Latex free, "Soiled Linen" printed in English and Spanish

CAT NO.	DESCRIPTION
20-9360	29" x 43", 1.1 mil, 33gal, Blue 200/CS (8 Rolls)
20-9362	29" x 43", 1.1 mil, 33gal, Mint Green 200/CS (8 Rolls)
20-9364	29" x 43", 2.0 mil, 33gal, Blue 100/CS
HIGH DENSITY	
20-9366	31" x 43", 17 mil, 33gal, Blue 250/CS (10 Rolls)



**DONT' SEE WHAT YOU ARE LOOKING FOR?  
WE WILL SOURCE IT FOR YOU**



## RED "BIOHAZARD" LINERS

- Latex Free, Super Strong X-Seal Bag is designed without gussets. The X-Seal significantly reduces the seal to minimize seal failures. Bag conforms to the containers shape and distributes the weight of the refuse evenly around the bag, eliminating leakage problems. Printed in English and Spanish.

CAT NO.	DESCRIPTION
20-9270	12" x 12", 1.5 mil, 1 gal, 1,000/Case, Zip Closure
20-9271	17" x 17", 1.5 mil, 4 gal, 500/Case
20-9273	24" x 24", 1.2 mil, 10 gal, 500/Case
20-9274	24" x 26", 1.5 mil, 10 gal, 200/Case
20-9275	24" x 32", 1.2 mil, 15 gal, 500/Case
20-9276	30" x 37", 1.2 mil, 25 gal, 250/Case
20-9277	30" x 44", 1.5 mil, 30 gal, 100/Case
20-9278	31" x 43", 1.2 mil, 33 gal, 200/Case
20-9279	31" x 43", 2 mil, 33 gal, 500/Case
20-9280	40" x 46", 3 mil, 40 gal, 50/Case
20-9281	40" x 46", 1 mil, 40 gal, 100/Case
20-9282	40" x 46", 1.2 mil, 45 gal, 100/Case
20-9283	40" x 46", 2 mil, 50 gal, 100/Case
20-9284	40" x 55", 3 mil, 55 gal, 50/Case
HIGH DENSITY LINERS	
20-9285	24" x 24", 13mic, 10 gal, 1,000/Case
20-9286	24" x 33", 11mic, 15 gal, 500/Case
20-9287	31" x 43", 14mic, 33 gal, 250/Case
20-9288	36" x 48", 17mic, 45 gal, 250/Case



**VOLUME DISCOUNTS AND CONTRACT PRICING AVAILABLE**



## POST MORTEM SURGICAL NEEDLES

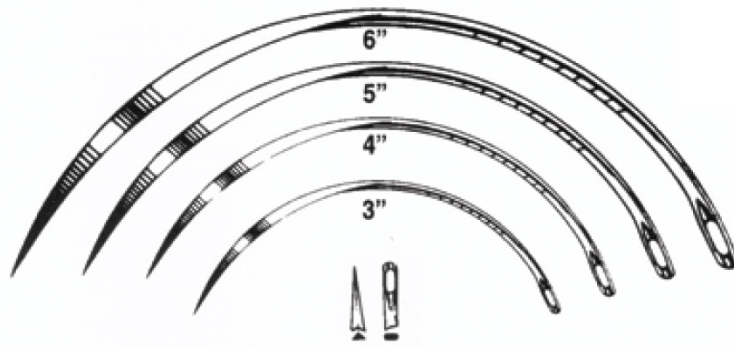

- 3/8 Circle Cutting Edge  
Style 816

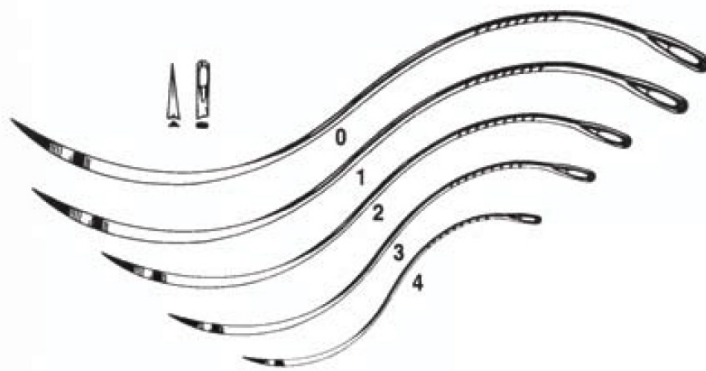

- "SERPENTINE"
- Double Curved Cutting Edge  
Style 819

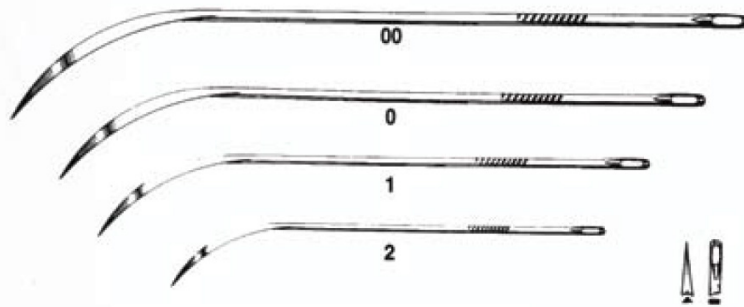

- HALF CURVED CUTTING EDGE  
Style 820

STAINLESS, NON STERILE SUTURE NEEDLE		
CAT NO.	DESCRIPTION	SIZE
1 Dozen / Pack		
C8-816	3/8 Circle-Cutting	(3-6)
C8-819	Double Curved Cutting	(0-4)
C8-820	Half-Curved Cutting	(00-2)

**WE MAINTAIN STOCK LEVEL FOR MOST ITEMS**

## POST MORTEM STAPLER

- The Postmortem Skin Stapler is Preloaded with 35W Staples, May Be Cold Sterilized Between Uses.

CAT NO.	QTY
ST-800	EACH
ST-802	5/BOX



## SURGICAL SKIN MARKERS

Latex Free Sterile Marking Pen provides non-toxic ink mark on skin and stays visible after-surgical prep.

- Sterile Pen
- QUANTITY: 50/Case

CAT NO.	DESCRIPTION
62-001	STERILE PEN WITH RULER
62-002	STERILE PEN WITH RULER AND LABELS



## WAXED POLYESTER SUTURE THREAD

Fine Waxed Polyester Thread, Moisture and Mildew Proof, Will Not Tear Flesh, Chemical Resistant, Eases the Sewing Operation, Tight, Strong and Firm, An Excellent Suturing Medium.

- Non Sterile
- Large 4oz. Spools

CAT NO.	DESCRIPTION
300	7 CORD, WHITE
310	3 CORD, WHITE



## LINEN SUTURE THREAD

Finest quality spun linen suture thread with exceptional tensile strength and smooth, uniform lay. For all purpose post-mortem stitching.

- Non Sterile
- Available in Waxed and Unwaxed Thread
- 1 lb. Spools

CAT NO.	DESCRIPTION
320	7 CORD, UNWAXED
330	7 CORD, WAXED



**WE MAINTAIN STOCK LEVEL FOR MOST ITEMS**

## NATURAL TAN POLYESTER SUTURE THREAD

7 Cord, Waxed Polyester Thread. Excellent for all common suturing and ligating operations. Strong and pliable.

- Non Sterile
- Waxed
- 1 lb. spools



CAT NO.	DESCRIPTION
360	WAXED POLYESTER, NATURAL TAN

## BRAIDED COTTON SUTURE THREAD

7 Cord, unwaxed. Excellent for all common suturing and ligating operations. Braided Cotton Thread, soft, strong and pliable.

- Non Sterile
- Unwaxed
- White
- 1 lb. spools



CAT NO.	DESCRIPTION
340	BRAIDED COTTON

**VOLUME DISCOUNTS AND CONTRACT PRICING AVAILABLE**

## HYPODERMIC NEEDLES

- Long Lasting Piercing Points. Luer Hubs.
- Stainless Steel

CAT NO.	SIZE
12-11	20 Gauge x 1.5"
12-12	20 Gauge x 2.5"
12-13	19 Gauge x 3"
12-14	15 Gauge x 3.5"
12-15	15 Gauge x 4"
12-16	15 Gauge x 5"
12-17	15 Gauge x 6"
12-18	13 Gauge x 8"
12-19	13 Gauge x 10"
12-24	13 Gauge x 4.5"
12-25	13 Gauge x 3"
12-26	13 Gauge x 1.5"
12-20	12 Gauge x 3"
12-21	12 Gauge x 4"
12-22	12 Gauge x 5"
12-23	12 Gauge x 6"

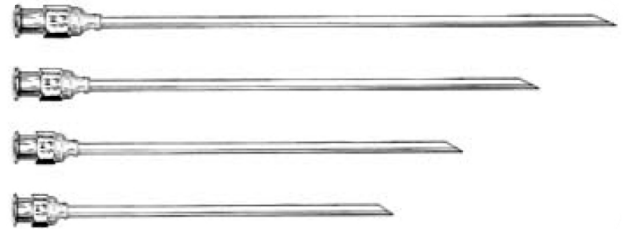

## 35 cc SYRINGE WITHOUT NEEDLE

3 cc SYRINGE STERILE		
CAT NO.	DESCRIPTION	PKG.
• Bold Graduations 1 cc and 1/4oz		• Latex Free
SWD535762	35 cc Syringe, Luer Lock Tip	180 Ea/Cs
SWD535762Z	35 cc Syringe, Luer Lock Tip	30 / Box

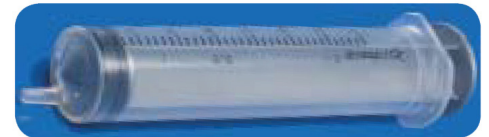

## 60 cc SYRINGE WITHOUT NEEDLE

3 cc SYRINGE STERILE		
CAT NO.	DESCRIPTION	PKG.
• Bold Graduations 5 cc and 1/4oz		• Latex Free
SWD560125	60 cc Syringe, Luer Lock Tip	120/Case
SWD560125Z	60 cc Syringe, Luer Lock Tip	30 / Box



**DONT' SEE WHAT YOU ARE LOOKING FOR?  
WE WILL SOURCE IT FOR YOU**

## SYRINGE WITHOUT NEEDLE

3 cc SYRINGE STERILE		
CAT NO.	DESCRIPTION	PKG.
• Bold Graduations 0.1 cc • Latex Free		
SWD513934	3 cc Syringe, Luer Lock Tip	1000/Case
SWD513934Z	3 cc Syringe, Luer Lock Tip	100/Box

6 cc SYRINGE STERILE		
CAT NO.	DESCRIPTION	PKG.
• Bold Graduations 0.2 cc • Latex Free		
SWD516937	6 cc Syringe, Luer Lock Tip	500/Case
SWD516937Z	6 cc Syringe, Luer Lock Tip	50/Box

10 cc SYRINGE STERILE		
CAT NO.	DESCRIPTION	PKG.
• Bold Graduations 0.2 cc • Latex Free		
SWD512852	12 cc Syringe, Regular Luer Tip	480/Case
SWD512878	12 cc Syringe, Luer Lock Tip	480/Case
SWD512878Z	12 cc Syringe, Luer Lock Tip	80/Box

20 cc SYRINGE STERILE		
CAT NO.	DESCRIPTION	PKG.
• Bold Graduations 1 cc • Latex Free		
SWD520673	20 cc Syringe, Regular Luer Tip	300/Case
SWD520673Z	20 cc Syringe, Regular Luer Tip	50/Box
SWD520657	20 cc Syringe, Luer Lock Tip	300/Case
SWD520657Z	20 cc Syringe, Luer Lock Tip	50/Box



**WE MAINTAIN STOCK LEVEL FOR MOST ITEMS**



## ECONOMY PATHOLOGY CONTAINERS

- Durable Polypropylene, Snap Lock Lids that Minimize Leaking.
- Can Be Frozen without Cracking

CAT NO.	DESCRIPTION
620-255	8 oz, 250 / Case
620-260	16 oz, 100 / Case
620-265	32 oz, 100 / Case
620-270	64 oz, 50 / Case
620-275	165 oz, 25 per Case



## POLYPRO CONTAINERS with SCREWCAPS

Durable Polypropylene containers are the ultimate in leak-tight storage and transportation of liquids. An expanded inner liner in the screwcap is designed to compress against the uppermost wall and top rim of the container providing an air-tight seal.

CAT NO.	CAPACITY	DIAMETER	HEIGHT	QTY
380-518	20 ml	1 1/2"	1 3/4"	1000
380-520	40 ml	2"	1 5/8"	600
380-522	60 ml	2"	2 3/8"	500
380-524	90 ml	2 1/4"	2 1/2"	400





## POLYPROPYLENE JARS

- Polyethylene plastic jars with lined Polypropylene secure screw cap.
- Available in assorted sizes and volumes
- Excellent for all Industries
- Autoclavable
- COLOR: Opaque

CAT NO.	OZ	QTY	DIMENSIONS
380-6361	1/4 oz	2783	1" x 1"
380-6363	1/2 oz	2024	1" x 1 7/16"
380-6365	7/8 oz	1452	1" x 1 7/8"
380-6367	1 oz	980	1 3/8" x 1 7/16"
380-6371	2 oz	585	1 5/8" x 1 5/16"
380-6373	2 oz	588	1 13/16" x 1 11/16"
380-6375	3 oz	432	1 15/16" x 2"
380-6377	4 oz	280	1 15/16" x 2 3/8"
380-6381	4 oz	528	2 7/16" x 2 3/16"
380-6383	6 oz	432	2 7/16" x 2 5/8"
380-6387	8 oz	336	2 7/16" x 3 3/8"
380-6391	4 oz	510	3 3/16" x 1 3/8"
380-6393	6 oz	390	3 3/16" x 1 7/8"
380-6395	8 oz	300	3 3/16" x 1 3/8"
380-6397	12 oz	240	3 3/16" x 3"
380-6399	16 oz	180	3 1/8" x 4"
380-6401	20 oz	150	3 1/8" x 5"



## POLYSTYRENE JARS

- Polystyrene plastic jars with lined Polypropylene secure screw cap.
- Available in assorted sizes and volumes
- COLOR : Clear

CAT NO.	OZ	QTY	DIMENSIONS
380-6360	1/4 oz	2783	1" x 1"
380-6362	1/2 oz	2024	1" x 1 7/16"
380-6364	7/8 oz	1452	1" x 1 7/8"
380-6366	1 oz	980	1 3/8" x 1 7/16"
380-6370	2 oz	585	1 5/8" x 1 5/16"
380-6372	2 oz	588	1 13/16" x 1 11/16"
380-6374	3 oz	432	1 15/16" x 2"
380-6376	4 oz	280	1 15/16" x 2 3/8"
380-6380	4 oz	250	2 7/16" x 2 3/16"
380-6382	6 oz	200	2 7/16" x 2 5/8"
380-6386	8 oz	150	2 7/16" x 3 3/8"
380-6390	4 oz	224	3 3/16" x 1 3/8"
380-6394	8 oz	140	3 3/16" x 1 3/8"
380-6396	12 oz	112	3 3/16" x 3"
380-6398	16 oz	84	3 1/8" x 4"
380-6400	20 oz	56	3 1/8" x 5"



# SPECIMEN TRANSPORT POUCH

## SPECIMEN POUCH

Bags are individually pre-printed with the biohazard symbol. Designed for safe storage/transportation of specimens with easy to store document compartment.

- Zipper closure allows unlimited access to bag
- Pre-printed with biohazard symbol
- 1,000 per Case / 10 per Pack

CAT NO.	DIMENSIONS
620-251	6" x 6"
620-261	6" x 9"
620-271	8" x 8"



**DONT' SEE WHAT YOU ARE LOOKING FOR?  
WE WILL SOURCE IT FOR YOU**

## SPECIMEN TRANSPORT POUCH

2 mil gauge polyethylene, designed for the safe transportation of specimens and documentation. Each bag is preprinted with the biohazard symbol and provides checkmarks to indicate handling instructions.

- Zipper closure allows unlimited access to bag
- Attached Document Compartment
- Pre-printed with biohazard symbol
- 1,000 / Case

CAT NO.	DIMENSIONS
380-918	6" x 9", Zipper Closure
380-922	6" x 9", Zipper Closure with Tear Zone
380-925	8" x 10", Zipper Closure with Tear Zone
380-928	12" x 15", Zipper Closure with Tear Zone
<b>RED TINT SPECIMEN STAT BAGS</b>	
380-950	6" x 9", Zipper Closure with Tear Zone
380-950A	6" x 9", Zipper Closure
<b>SPECIMEN TRANSPORT BAGS with GLUE CLOSURE</b>	
380-921	6" x 9", Glue Closure
380-923	6" x 9", Glue Closure, Absorbent Pad / 500 Bags



**WE MAINTAIN STOCK LEVEL FOR MOST ITEMS**

**UTILITY CART, STAINLESS STEEL**

- Three (3) Shelf Utility Cart with 4" Rubber Wheel for Easy Mobility.
- Stainless Steel Construction

CAT NO.	DESCRIPTION
76-1002	24" x 18" x 35" 350 lb. Cart Capacity
76-1003	22" x 39 1/4" x 37 1/4" 350 lb. Cart Capacity
76-1004	27 1/2" x 16 1/4" x 32 1/8" 300 lb. Cart Capacity

**3 SHELF UTILITY CART STAINLESS STEEL**

- Stainless Steel Construction for easy cleaning. Standard leg and handle bumpers protect cart, walls and doorways from damage.
- Weight Capacity 200 lbs
- L : 27 1/2" x W : 16 1/4" x H : 46"

CAT NO.	DESCRIPTION
76-1010	200 lb. Cart Capacity
76-1012	200 lb. Cart Capacity with Nylon Cover



**STAINLESS PRODUCTS CAN BE MADE TO YOUR SPECS**

## SERVICE CART

Heavy-Duty 400 lbs Capacity. Molded Handle, Impact Resistant Reinforced Edge. No Sharp Edges. Lighter Than Metal For Easy Maneuverability. Easily to Assemble. Third Shelf Option Available.

CAT NO.	DESCRIPTION
RUB4520	2 Shelves
L 45" x W 25" x 33"	



## INSTRUMENT CART

This innovative INSTRUMENT CART provides a portable workstation complete with locking cabinet and sliding top drawer. Shelves are smooth and easy to clean. Large, quiet, non-marking casters make this cart a perfect choice for morgues and laboratory. Smooth rounded corners help protect walls. "Pound together" design makes assembly easy and fast. Available in gray. Maximum cart load capacity is 300 lbs.

CAT NO.	DESCRIPTION
RUB2040	L 40 <sup>3</sup> / <sub>5</sub> " x W 20 <sup>3</sup> / <sub>4</sub> " x H 37 <sup>4</sup> / <sub>5</sub> "



**VOLUME DISCOUNTS AND CONTRACT PRICING AVAILABLE**

## AUTOPSY SCALE HANGER BRACKET

### STANDARD DESIGN FEATURES:

The Scale Hanger Pole is fabricated from Type 304 polished Stainless Steel with .120" wall thickness. Welding is of the heliarc method and all welds are polished to match adjoining surfaces. A stainless steel support is welded to the vertical and horizontal bars for added strength. A location for scale attachment is provided. The pole bracket is custom fabricated from 0.25" thick Type 304 polished stainless steel.

Pole is provided with a locking knob which allows the pole to be secured anywhere along its 360 degree turning ability.

CAT NO.	DESCRIPTION
90-0000	Bracket for Wall Mounted Autopsy Sink Station
90-0002	Bracket for Pedestal Mounted Autopsy Sink Station
90-0004	Bracket for Wall Mounting





**AUTOPSY SCALE STAND On Casters****CAT NO.**

90-0006

**STANDARD DESIGN FEATURES:**

The portable stand on casters is a supplement to the Scale Hanger Pole which is fabricated from Type 304 polished Stainless Steel with .120" wall thickness. Welding is of the heliarc method and all welds are polished to match adjoining surfaces. A stainless steel support is welded to the vertical and horizontal bars for added strength. A location for scale attachment is provided. The pole bracket is custom fabricated from 0.25" thick Type 304 polished stainless steel. Pole is provided with a locking knob which allows the pole to be secured anywhere along its 360 degree turning ability.



**HSDC SERIES SCALE**

The HSDC Scale is a Battery Powered, Fully Featured Hanging Digital Scale

Sleep and Auto Shut-off Mode to Extend your Battery Life

Aluminum Alloy Construction makes it Lightweight and Durable

Easy to Use

All Models are Furnished with a Hook

- Perfect for Portable Weighing
- Battery Powered: 6 "C" Alkaline Batteries (Not Includ
- Large LCD Display: 1" High
- Push Button Tare
- Auto Shut-Off and Sleep Mode
- Finish: Head - Aluminum Alloy

"Legal for Trade" Meets or Exceeds NIST  
Recommendations for a Class III Weighing Devices

CAT NO.	CAPACITY	GRADUATION
31-HSDC-20	20 lb	.01 lb.
31-HSDC-40	40 lb.	.02 lb.
31-HSDC-20K	20 kg	.01 kg.

**FEATURES & SPECIFICATIONS:**

- Scale Weight: 5 lbs ( 10 lbs. With Optional Pan).
- Operating Temperature: -10o to over 40oC/14o to 104oF.
- Display Type: 1" High LCD.
- Power: 6 "C" size alkaline (Not Included)
- Battery Life: 1 Year Continuous Use.
- Zero : Established during setup and maintained automatically to + 1/4 graduation.
- Stainless Steel Pan: 12.5" diam. x 5" depth; 8 qt. (500 cu. in.) volumetric capacity.

## 9" DIAL HANGING SCALES

Used by Hospitals, Laboratories and Universities as Required Equipment. These quality scales offer the highest accuracy, reliability and precision.

### FEATURES:

- 9" Diameter Glass-Covered Dial
- Chrome Plated Steel Outer Band and Glass-Retaining Sash
- Machined Stainless Steel Pinions
- Capacity is Reached in Three Pointer Revolutions. Runners are Indexed for Each Revolution
- Available with Deep Stainless Steel Pan (AS) or with a Bottom Hook
- The Models with Hook can be Started for Weights of your Particular Loading Attachments

MODEL NO.	CAPACITY
815AS	15 kg x 20 g (with Pan)
815 H	15 kg x 20 g (with Bottom Hook)

## 13" DIAL HANGING SCALES

Used by Hospitals, Laboratories and Universities as Required Equipment. These quality scales offer the highest accuracy, reliability and precision.

### FEATURES:

- 13" Diameter Glass-Covered Dial
- One Dial Reads Clockwise, the Opposite Reads Counterclockwise
- Chrome Plated Steel Outer Band and Glass-Retaining Bezels
- Machined Stainless Steel Pinion and Phosphor Bronze rack Combination Assure Low Friction Performance at Elevated Temperatures
- Two Brass Air Dashpots stop pointer oscillation
- Capacity is Reached in Three Pointer Revolutions. Runners are Indexed for Each Revolution
- Available with Deep Stainless Steel Pan (AS) or with a Bottom Hook
- The Models with Hook can be Started for Weights of your Particular Loading Attachments

MODEL NO.	CAPACITY
1315 ASDD	15 kg x 25 g (with Pan)
1315 HDD	15 kg x 25 g (with Bottom Hook)
1309 ASDD	9 kg x 10 g (with Pan)
1309 HDD	9 kg x 10 g (with Bottom Hook)



DETECTO's exclusive digital solar hanging scale is powered completely by light and never requires battery replacement. The model SCS30 is NTEP approved legal for trade making it ideal for grocery stores, farmers markets, hardware stores, and roadside produce stands where customers pay by weight. The 30 lb/15 kg capacity and 0.01 lb/0.005 kg divisions offer you pinpoint measurement accuracy. The bold 1-inch-high LCD displays instant digital readouts. A stainless steel produce pan, hanging assembly, and two S-hooks are included, so the solar-powered scale is ready to use right out of the box, just add light! Requires minimum 400 lux. Optional stand available.

## FEATURES:

- 30 lb / 15 kg Capacity
- Automatic Zero Tracking
- Digital Speed for Instantaneous Weight Readouts
- Easy to Operate – No Buttons to Press
- Exclusive Solar Powered Design
- Includes Stainless Steel Produce Pan and 2 S-Hook
- Large 1-in/25-mm High Digits
- Never Replace a Battery – Completely Solar Power
- NTEP Legal for Trade

## Optional Stand Available (Model HS-STAND)



## Model: SCS30

**Capacity: 30lb x 0.02lb / 15kg x 0.01kg**

Unit Conversion: lb / kg

Power: Solar cell

Solar Type: Amorphous silicon solar panel

Lighting Requirements: Minimum 400 lux

Recommended Placement: Indoors – direct light | Outdoors – indirect light

(NOTE: Do not operate the SCS30 in direct sunlight)

LCD Digits: Five-digit, seven-segment, 1.0 in / 25 mm high bold digits

Annunciators: lb, kg, zero, solar charge status

Button: Zero/Tare button (located on bottom of scale)

Certification: NTEP legal for trade

Accuracy Class: III

NTEP Certificate: 15-009

Temperature Range: 32° F to 104° F (0° C to 40° C)

Construction: Polycarbonate scale, stainless steel pan and bow

Includes: SCS30 digital scale, 2 S-hooks, 1 bow assembly, 1 ring assembly, 2 pan bow nuts, 2 wing nuts 5/16-18, 1 pan with 3 drainage holes

LCD Display Size: 3.9 in W x 1.4 in H / 9.9 cm W x 3.6 cm H

Scale Dimensions: 8.8 in diameter x 3.8 in D / 22.4 cm diameter x 9.7 cm D (round portion)

Overall Dimensions: 16 in W diameter x 32 in H / 40.6 cm W diameter x 81.3 cm H (including all components)

**Pan Dimensions: 13.7 in diameter x 4.4 in H / 34.8 cm diameter x 11.2 cm H**

Product Weight: 4.5 lb / 2.0 kg

UPC Code: 809161194401

Optional: Portable hanging scale stand (model HS-STAND)

Solar Panel Dimensions: 5 in W x 3.4 in H / 127 mm W x 86 mm H

## OHAUS SCOUT

An Economical PORTABLE Scale

The OHAUS Scout, perfect for both laboratory and industrial use, features a slim and stackable design, along with a large backlit LCD screen.

- The Scout's bright backlit LCD and simple 4-button control ensure efficient operation and user-friendly experience.
- Benefitting from advanced overload protection and sturdy pan support, the balance is safeguarded against shocks and overloading in tough environments.
- Improved performance and higher capacities broaden the range of weighing applications. Faster stabilization times, as quick as 1 second, and advanced weighing technology enhance productivity in your facility, while increased capacity enables a wider variety of weighing tasks.



CAT NO.	SPX621
Capacity x Readability (g)	620 x 0.1
Linearity (g) Pan	+ -0.1
Size (in/cm)	96.7 X 5.5 / 17.0 X 14.0
Dimensions (W x H x D)(in/cm)	8.0 x 8.8 x 2.1 / 20.2 x 22.4 x 5.4
Span Mass (g)	300

**VOLUME DISCOUNTS AND CONTRACT PRICING AVAILABLE**

## OHAUS VALOR™ 2000

Compact PORTABLE Washdown Scale

The OHAUS Valor 2000 food scale sets a new standard for speed and durability. It features water-resistant design options, large LED displays, and food safety keypads, making it ideal for dry or washdown environments.



- NEMA 4 / IP65 Washdown Protection
- 1:6,000 or 1:7,500 maximum displayed resolution
- NSF Listed/Certified, USDA-AMS Accepted, supports HACCP systems
- ABS housing, dishwasher-safe removable stainless steel pan
- Dual LED displays (front and back of housing)
- Lb, oz, g or kg
- AC power adapter or 50 hour internal rechargeable battery (included)

CAT NO.	V21PW3	V21PW6	V22XW6
Capacity x Readability (g)	3000 x 0.5	6000 x 1	6000 x 1
Display Indicators	Stability, center of zero, net, battery status		
Pan Size (in/cm)	7.5 x 9.5 / 19.0 x 24.2		
Dimensions (W x H x D)(in/cm)	10.1 x 11 x 4.8 / 25.6 x 28.0 x 12.1	256 x 288 x 124 mm / 10.1 x 11.3 x 4.9 in	
Net Weight	3000 g / 6.6 lbs	3900 g / 8.6 lb	

**DONT' SEE WHAT YOU ARE LOOKING FOR?  
WE WILL SOURCE IT FOR YOU**



## OHAUS VALOR™ 3000 XTREME

High Performance Easy to Use PORTABLE Scale

The Valor 3000 Xtreme offers high precision readability, durability, and ease-of-use, in a sleek and stainless steel housing. Washdown versions models ensure that the Valor 3000 Xtreme meets the needs of even the most demanding environments.



- 10x capacity rated overload protection
- Easy-to-clean stainless steel pan and housing
- Bright backlit LCD SmarText™ user interface guides user throughout application use and scale setup

CAT NO.	V31XW301	V31XH2	V31XW3	V31XW6
Capacity x Readability (g)	300 x 0.1	2000 x 0.1	3000 x 0.5	6000 x 1
Linearity (g)	0.2	0.1	1	1
Pan Size (in/cm)	5.8 x 6.2 / 14.6 x 15.8			
Dimensions (W x H x D)(in/cm)	8.5 x 7.3 x 3 / 21.8 x 18.6 x 7.7			
Span Mass (g)	300	2000	3000	6000

### OHAUS VALOR™ 3000 XTREME ACCESSORIES

ORDER NO.	DESCRIPTION
80251216	Hard Shell Carrying Case
80251147	Sandwich Pan, 11 x 5.9 x 0.4 in.
80251148	French Fries Holder Pan
80251149	Ice Cream Cone Holder Pan
80250400	Stainless Steel Scoop 12 x 6 x 2.75 in.

## OHAUS COMPACT

### An Economical PORTABLE Scale

From the laboratory to the field, Our Compact Scales are reliable and easy to use. The portable Compact moves with you to any environment and has a long battery life for all-day field experiments. Consistent and quick weighing has never been so easy!

- Best overall overload protection and durability in the class
- Superior RF protection for use in production areas
- Available with Postal charts and metal holder letters



CAT NO.	CX2200	CS5000
Capacity x Readability (g)	2200 x 1	5000 x 1
Linearity (g)	+1	+1
Pan Size (in/cm)	5 x 5.6 / 12.8 x 14.2	5.75 x 5.25 / 14.5 x 11.3
Dimensions (W x H x D)(in/cm)	5.3 x 7.9 x 1.6 / 13.5 x 20.1 x 4.1	8.0 x 5.5 x 1.5 / 20.3 x 14.0 x 3.8
Span Mass (g)	1000	2000

**VOLUME DISCOUNTS AND CONTRACT PRICING AVAILABLE**



## CL-SERIES

### PORTABLE Weighing at an Affordable Price

The OHAUS CL is a portable scale for basic weighing in grams. Two easy-to-use buttons let you start weighing right out of the box. Use it in the office, lab or carry it with you anywhere.

Simple Weighing at an affordable price

- Load cell lock protects scales when transported or stacked for storage
- Auto shut-off



CAT NO.	CL201	CL2000	CL5000
Capacity x Readability (g)	200 x 0.1	2000 x 1	5000 x 1
Linearity (g)	+ -1	+ -1	+ -1
Pan Size (in/cm)	4.75 / 12.0		
Dimensions (W x H x D)(in/cm)	5.5 x 1.6 x 7.9 / 14.0 x 4.0 x 20.0		
Span Mass (g)	100	100	200

**DONT' SEE WHAT YOU ARE LOOKING FOR?  
WE WILL SOURCE IT FOR YOU**

## SECA 727 - Electronic Baby Scale with Integrated Printer Interface

A special integrated damping together with the HOLD function for quick, precise weighing even if the baby is restless. The ergonomically formed tray with high rounded sides make it easy to weigh larger babies. The large, bright LED figures make it easy to read the result. The integrated RS232 interface guarantees the reliable transmission of data to a PC or printer.

### OPTIONAL ACCESSORIES:

- 451 Interface Cable
- 425 Transport Case
- A/C UL Adapter

FEATURES	
Capacity	44 lbs / 20 kg
Graduation	0.1 oz < 22 lbs > 0.2 oz 2 g < 10 kg > 5 g
Dimensions (WxHxD)	22 x 6 x 12.5"
Tray (WxHxD)	21 x 1.5 x 9.8"
Weight	11 lbs
Power supply	A/C UL adapter OR battery
Warranty	2 years
Function	TAKE, HOLD, weighing range switch-over lbs/kg switch-over
Measuring Range:	4 - 39" / 10 - 99 cm"
Graduation:	1/4" / 5 mm



## SECA 210 - Measuring Mat

for Babies & Toddlers

Precise measurement, fixed head piece & easy slide foot positioner, washable & foldable



## SECA 374 - Electronic Baby Scale

with Extra Large Weighing Tray  
Suitable for babies & Infants up to 40 lbs

The shell-shaped design of the seca 374 is consistent with the high demands made on its multiple functions: the large tray provides maximum safety against the baby falling from the scales. The clear controls of the user interface are located on the slightly raised, ergonomically formed side of the scales facing the user. A large LCD display makes it quick and easy to determine the weight. The extremely robust, hygienic surface of high-quality plastic is easily and quickly cleaned.

FEATURES	
Capacity	44 lbs / 20 kg
Graduation	0.2 oz < 22 lbs > 0.5 oz 5 g < 10 kg > 10 g
Dimensions	W24.5 x H7.5 x D14"
Tray	W24.5 x H2.7 x D12"
Weight	7 lbs
Power supply	Batteries or A/C UL adapter optional
Warranty	2 years

### OPTIONAL ACCESSORIES:

- 418 - Head & Foot Positioner
- Dimensions: 205x 148 x 69 mm
- Weight 0.9 lbs

### FUNCTION:

- TAKE, HOLD, weighing range
- switch-over lbs/kg switch-over





## SECA 656 - PLATFORM SCALE on Wheels For STRETCHERS or GUERNEYS

### SPECIFICATIONS

Capacity	800 lbs / 360 kg
Graduation	0.2 lbs / 100 g

The platform of the SECA 656 makes it possible to weigh patients on all common roll-in systems or stretchers with integrated and separate under carriages. Thanks to its extremely robust construction and very high capacity of 360 kg, it is possible to weigh even heavyweight patients with little effort. With the practical transport castors and the integrated handle, the scale can be moved arounda easily and can thus be used in different locations. The cable remote display, can be wall mounted or placed on a table.

### OPTIONAL ACCESSORIES:

- 460 - RS232 interface
- 472 - stand seca
- 470 - Ramp

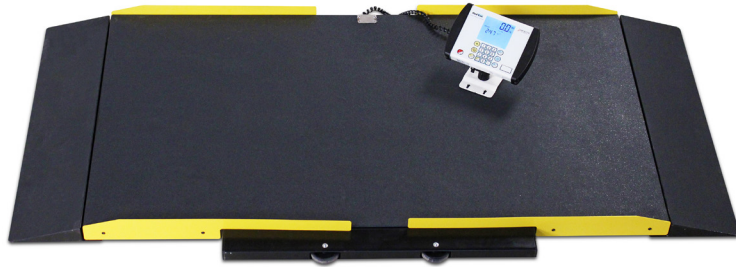

### FUNCTIONS:

Pre-TARE with 3 storage spaces for additional weights, TARE, HOLD,  
BMI with 3 storage spaces for heights, damping, kg/lbs/sts switch-over





**PS1000 & PS2000**  
**Portable PLATFORM SCALE By Salter Brecknell**  
**For STRETCHERS or GUERNEYS**

Fitted with two easy access carrying handles that makes this scale convenient to relocate. No need for ramps or recessed floors, as this unit comes with ramped ends. Rugged steel construction with tread plate surface protects from accidental slips and falls.

**Adjustable** – foot pads allow scale to work effectively on uneven floors.

**Accurate** – Consistent accuracy within 0.1% Equipped with an indicator for fast digital read out.

**Overload Capacity** – Capable of withstanding 150% capacity of weight without damaging the scale.

**Easy Assembly** – No installation costs or parts that require maintenance. Just place the scale on a hard surface and level by adjusting the foot pads. Connect the indicator and turn on the power.

**Economical** – There are no installation costs and no moving parts that require maintenance or adjustment.



SPECIFICATIONS	
Capacity	1000 lbs / 2000 lbs
PS1000	1,000 lb x 0.5 lb (500 kg x 0.2 kg)
PS2000	2,000 lb x 1.0 lb (1000 kg x 0.5 kg)
Power	Four (4) AAA batteries or 6 VDC, 500m A adapter, both included
Operating Temp	41° F to 95° F (5° C to 35° C)
Battery Life	20 hours
Display	Five 0.625" digits (17 mm) LCD
Serial Port	One full duplex RS232, with cable
Keyboard	Hold/Print, Units, Tare, On/Off/Zero
Unit	lb, kg, lb/oz
Low Profile	2.50" high



**Alpha Air®**

The AlphaAir facemasks are clean, comfortable and provide outstanding particle filtration down to 0.1 micron. The full-length aluminum nosepiece and sonic welded design ensures maximum protection for the user. These masks are available with tie strings or ear loops. Hypoallergenic Latex Free Particle Filtration to 0.1 micron

**FACE MASK with TIES**

- 100% Polypropylene
- Hypoallergenic
- Latex Free
- Particle Filtration to 0.1 micron

CAT NO.	DESCRIPTION	QTY
35-2530	Tie Mask, BLUE	300/Case (50/Bx)

**FACE MASK with EARLOOPS**

- 100% Polypropylene
- Hypoallergenic
- Latex Free
- Particle Filtration to 0.1 micron

CAT NO.	DESCRIPTION	QTY
35-2534	Ear Loop, Blue	500/Case (50/Box)

**COOLOne™ FACE MASKS**

This face mask features exclusive Magic Arch design, Hypoallergenic & Fluid Resistant. Magic Arch support keeps the mask away from your nose & mouth without restricting downward vision, providing a cooler, more comfortable breathing chamber

- Latex Free

CAT NO.	DESCRIPTION	PACKAGING
35-6002B	Earloop, Blue	500/Case, 10Bx/50
35-6002G	Earloop, Blue	500/Case, 10Bx/50
35-6002P	Earloop, Green	500/Case, 10Bx/50
35-6002Y	Earloop, Pink	500/Case, 10Bx/50





## ShieldMate® Eye Shield Protector

### Mask & Shield Combination Provides the Added Security of Eye Protection.

5 mil LATEX FREE shield is ultrasonically welded to the mask & is anti-fog treated on both sides. It includes an anti-fog foam strip at the nosepiece to eliminate fogging of eyeglasses. The mask incorporates the **Magic Arch®** support strip, which holds the mask away from the nose & mouth providing a larger breathing chamber.

### FACE MASKS with TIES, EYE SHIELD

- 100% Polypropylene
- Hypoallergenic
- Particle Filtration to 0.1 micron

CAT NO.	DESCRIPTION	QTY
35-2538	Tie Mask, Blue	100/Case (4Bx/25)



### SHIELDMATE™ MASK WITH EXTENDED SHIELD

Wrap around shield has permanent anti-fog treatment on both sides.

- 100% Polypropylene
- Latex Free
- 7 Mil thick
- Ear Loops
- Particle Filtration to 0.1 micron

CAT NO.	DESCRIPTION	QTY
35-3540	Earloop, Blue	100/Case (4Bx/25)



### BASIC ISOLATION FACE MASK

Full width nosepiece guarantees proper fit. Face mask features tissue inner and outer facing for light and comfortable wear.

- Latex Free
- QTY: 300 / case(6 boxes of 50)

CAT NO.	COLOR	QTY
35-7120	YELLOW	300/Case



### BASIC PROCEDURE FACE MASK

Features tissue inner & outer facing for comfort. Lightweight & comfortable to wear.

- Latex Free
- Ear Loops

CAT NO.	COLOR	QTY
35-7365	BLUE	300/Case(6Bx/50)





### N-95 Particulate Respirators with Positive Facial Lock® is NIOSH approved and meets CDC and WHO guidelines

PFL®(Positive Facial Lock) Masks are fluid resistant and feature the exclusive Twist-Seal® chin piece which allows a custom fit to any size face, reducing the potential of small particles to be inhaled around the borders of the face mask. This unique design virtually eliminates gaps at the border of the mask.

This Particulate Respirator is NIOSH approved and meets CDC and WHO guidelines. Features exclusive Magic Arch® and PFL® design. These unique design features permit the respirator to be "Custom Fit" to virtually any shape face.

- Double Headband
- Latex Free
- QTY: 210 / Case
- (6 Dispenser Boxes of 35)

CAT NO.	COLOR	QTY
35-2520	Teal Stripe	210/Case
35-2520B	Teal Stripe	35/Box



### N95 CONE-STYLE PARTICULATE RESPIRATOR MASK N-95 PARTICULATE RESPIRATOR, Meets NIOSH and CDC guidelines for T.B. exposure

- Positive Facial Lock®
- Double Bands Secure Mask In Place
- Micro filter protects against micron-size particles
- COLOR: White

CAT NO.	SIZE	PACKAGING
35-4502	Small	120/Case (6 Box/20)
35-4500	Regular	240/Case



### VISITOR SPECS

Lightweight protection for employees or visitors with a built in brow bar & side shields provide additional protection

- Unbreakable Plastic
- QTY: 12 / Box

CAT NO.	FRAME	LENS
35-2472	Large / Clear	Clear Lens



## PROTECTIVE FACE SHIELDS

### Designed for Total Splash Protection

The 7 mil shield is lightweight and can be worn comfortably for long periods. It can easily fit over glasses. Foam headband fits over glasses. Headband fits snugly against the forehead. Double sided anti-fog treatment virtually eliminates fogging. Optically clear with full peripheral vision.

- Individually Poly Bagged
- Anti-Fog Treatment Virtually Eliminates Fogging

CAT NO.	MIL	SHIELD	HEADBAND	QTY
35-2410	7	Half Face	Comfort/Latex Free	100/Case
35-2408	7	Full Face	Comfort/Latex Free	100/Case
35-2406	7	Half Face	Velcro Adjustable	100/Case
35-2404	7	Full Face	Velcro Adjustable	100/Case



## CONE STYLE MASK

Cup-shaped mask is held away from the nose & mouth for enhanced comfort & protection. Can be adjusted to further ensure that the mask remains securely in place.

- Comfortable
- Rounded edges
- Latex Free

CAT NO.	COLOR	QTY
35-7381	BLUE	300/Case (6Bx/50)



**VOLUME DISCOUNTS AND CONTRACT PRICING AVAILABLE**

**Economical General Use Garment  
Dry Particulate Protection  
Strong, Lightweight, Breathable Material  
Superb Barrier Properties**

Material incorporates an exclusive non-woven structure that produces a more breathable fabric without sacrificing barrier durability or integrity. The best available choice for clean rooms, and other applications where low linting is required. POLY-COATED TYVEK® is a standard Tyvek® which has been coated with 1.25 mils of polyethylene, offers excellent splash protection against many inorganic acids, bases and other liquid chemicals.

**DUPONT™ TYVEK® APRON**

- Superior Barrier Performance, Sewn Ties
- Meets ANSI/ISEA 101-1996 Specification

CAT NO.	SIZE	QTY
13-5002	28" x 36", White	100/Case



**DUPONT™ TYVEK® SLEEVES**

- Elastic At Both Ends, Serged Seams
- Meets ANSI/ISEA 101-1996 Specification

CAT NO.	SIZE	QTY
13-1600	18", White	100/Case

**BOUFFANT CAP**

- Bouffant Style, Serged Seams, 21" Diameter
- Clean Room Garment

CAT NO.	SIZE	QTY
13-1750	21", White	250/Case



**HOOD**

- Pullover Style, Serged Seams, Elastic Face
- Meets ANSI/ISEA 101-1996 Specification

CAT NO.	SIZE	QTY
13-0713	One Size, White	100/Case



**COVERALL WITH COLLAR**

- Full Cut for Comfort Fit, Serged Seams
- Set-in Sleeve, Non Sparkling Zippered Front
- Meets ANSI/ISEA 101-1996 Specifications

CAT NO.	SIZE	QTY
13-1001	Medium, White	25/Case
13-1002	Large, White	25/Case
13-1003	XLarge, White	25/Case
13-1004	2XLarge, White	25/Case
13-1005	3XLarge, White	25/Case



**COVERALL, WITH COLLAR, ELASTIC WRISTS & ANKLES**

- Full Cut for Comfort Fit, Serged Seams
- Meets ANSI/ISEA 101-1996 Specifications

CAT NO.	SIZE	QTY
13-1021	Medium, White	25/Case
13-1022	Large, White	25/Case
13-1023	XLarge, White	25/Case
13-1024	2XLarge, White	25/Case
13-1025	3XLarge, White	25/Case



**HOOD, ELASTIC WRISTS & ANKLES**

CAT NO.	SIZE	QTY
13-1060	Small, White	25/Case
13-1061	Medium, White	25/Case
13-1062	Large, White	25/Case
13-1063	XLarge, White	25/Case
13-1064	2XLarge, White	25/Case
13-1065	3XLarge, White	25/Case
13-1066	4XLarge, White	35/Case
13-1067	5XLarge, White	35/Case

**Economical General Use Garment**  
**Appropriate in a Non-Toxic Workplace**  
**Cool, Comfortable, Breathable Material**  
**Serged Seams**

Economical and disposable garments, appropriate for work in a non-toxic workplace.

### BOUFFANT CAP

- Spunbound Polypropylene Fabric
- Meets ANSI/ISEA 101-1996 Specs

CAT NO.	SIZE	QTY
13-1772	21", White	500/Case



### SLEEVES

Elastic at Both Ends, Serged Seams  
 Spunbound Polypropylene Fabric  
 Meets ANSI/ISEA 101-1996 Specs

CAT NO.	SIZE	QTY
13-1612	18", White	100 pairs/Case

### APRON

- Spunbound Polypropylene Fabric
- Meets ANSI/ISEA 101-1996 Specifications

CAT NO.	SIZE	QTY
13-1614	28" x 36", White	100/Case



### COVERALL WITH HOOD, ELASTIC WRISTS & BOOTS

- Spunbound Polypropylene Fabric
- Strong, Lightweight, Breathable Material
- Zippered Front, Serged Seams
- Meets ANSI/ISEA 101-1996 Specs

CAT NO.	SIZE	CASE
13-1100	Small, White	25/Case
13-1101	Medium, White	25/Case
13-1102	Large, White	25/Case
13-1103	XLarge, White	25/Case
13-1104	2XLarge, White	25/Case
13-1105	3XLarge, White	25/Case





## COVERALL with ZIPPER

- Spunbound Polypropylene Fabric
- Strong, Lightweight, Breathable Material
- Zippered Front, Serged Seams
- Meets ANSI/ISEA 101-1996 Specs

CAT NO.	SIZE	CASE
13-1090	Small, White	25/Case
13-1091	Medium, White	25/Case
13-1092	Large, White	25/Case
13-1093	XLarge, White	25/Case
13-1094	2XLarge, White	25/Case
13-1095	3XLarge, White	25/Case
13-1096	4XLarge, White	25/Case
13-1097	5XLarge, White	25/Case
13-1098	6XLarge, White	25/Case
13-1090N	Small, Navy	25/Case
Also Available in NAVY		

## ELASTIC WRISTS & ANKLES

CAT NO.	SIZE	CASE
13-1080	Small, White	25/Case
13-1081	Medium, White	25/Case
13-1082	Large, White	25/Case
13-1083	XLarge, White	25/Case
13-1084	2XLarge, White	25/Case
13-1085	3XLarge, White	25/Case
13-1086	4XLarge, White	25/Case
13-1087	5XLarge, White	25/Case
13-1088	6XLarge, White	25/Case
Also Available in NAVY		



Protective Apparel

**DONT' SEE WHAT YOU ARE LOOKING FOR?  
WE WILL SOURCE IT FOR YOU**



**SLEEVES**

- Tapered Sleeve, Elastic on Both Ends
- Spunbond Polypropylene
- Sonic Welded Seams, Length: 21.5"
- COLOR: WHITE

CAT NO.	SIZE	CASE
35-3108	UNI	300/Case (150 Pairs)
35-3109	XL	300/Case (150 Pairs)

**SLEEVES, Ultra Clean**

- For Sterile Work Areas, Individually Packed in Pairs

CAT NO.	SIZE	CASE
35-3118	UNI	300/Case (150 Pairs)
35-3119	XL	300/Case (150 Pairs)

**COVERALL with ELASTIC WRISTS & ANKLES**

- Full Cut for Comfort Fit
- Spunbond Polypropylene
- Zippered Front
- COLOR: WHITE

CAT NO.	SIZE	CASE
35-3120	Small	25/Case
35-3121	Medium	25/Case
35-3122	Large	25/Case
35-3123	XLarge	25/Case
35-3124	2XLarge	25/Case
35-3125	3XLarge	25/Case
35-3126	3XLarge	25/Case

**ELASTIC HOOD, WRISTS & ANKLES**

CAT NO.	SIZE	CASE
35-3132	Medium	25/Case
35-3133	Large	25/Case
35-3134	XLarge	25/Case
35-3135	2XLarge	25/Case
35-3136	3XLarge	25/Case
35-3137	3XLarge	25/Case

**ELASTIC HOOD, WRISTS & AquaTrak® BOOT**

CAT NO.	SIZE	CASE
35-3140	Small	25/Case
35-3141	Medium	25/Case
35-3142	Large	25/Case
35-3143	XLarge	25/Case
35-3144	2XLarge	25/Case
35-3145	3XLarge	25/Case
35-3146	4XLarge	25/Case



## VINYL SLEEVES, 4 mil

- Elastic on both ends for complete protection. Superior flexibility. Resistant to chemicals, fats and oils, grease, punctures and abrasions.

CAT NO.	SIZE	QTY
13-1622	18", Clear	24/Pack



## VINYL APRONS, Medium Weight

- Provides Strong Durable Protection.
- Made from high quality virgin vinyl. Superior flexibility & resistance to chemicals, fats and oils, grease punctures & abrasions

CAT NO.	SIZE	QTY
13-2332	6 mil, White, 33" x 44"	12/Pack



## POLY APRONS

A smooth formulated film that ensures quality and strength. Designed to protect against fluid while remaining cool and quiet.

- Polyethylene Bib Style Apron, Smooth Finish

CAT NO.	SIZE	CASE
14-2325	1.0 mil, White, 24" x 42"	100/Bx
14-2326	1.0 mil, White, 28" x 46"	100/Bx
1-910	1.25 mil, White, 28" x 46"	100/Bx



**WE MAINTAIN STOCK LEVEL FOR MOST ITEMS**

## POLY GOWN THUMB LOOP & ELASTIC CUFFS

A Cost Effective Replacement for Expensive Gowns, Aprons & Sleeves. Our Fluid Protective Barrier Gowns are Made of Heavy Duty EVA.

- One Piece Gown with Welded Seams
- Elastic Cuffs & Thumb Loops
- Open Back Provides Ventilaton
- Packaged in Individual Pouches
- COLOR: Blue

CAT NO.	SIZE	QTY
11-940	UNISIZE	50/Case
11-940XL	XLONG	50/Case



## BREATHABLE PROTECTION GOWN OPEN BACK & KNITTED CUFFS

This Lightweight, Breathable Fluid Protective, Laminated Spunbond Polypropylene Gown is LATEX FREE.

- Our Generous Sizing Enables Greater Coverage & Flexibility
- A Lengthy Waist & Neck Tie with Secure Knitted Cuffs
- Designed with an Open-Back
- Color: Blue

CAT NO.	SIZE	QTY
11-1920	UniSize	50/Case
11-1921	XLarge	50/Case



## LAMINATED POLYPRO PROTECTION GOWN OPEN BACK & KNITTED CUFFS

A Superior Lightweight Gown, Spunbond Polypropolyene with Coated Polyethylene.

- Latex Free
- Waist & Neck Ties to Ensure a Secure Fit
- Knitted Cuffs & Serged Seams
- Impervious to High Levels of Fluid
- Color: Blue

CAT NO.	SIZE	QTY
11-1930	UniSize	50/Case
11-1931	XLarge	50/Case



## REINFORCED PROTECTION GOWN CLOSED BACK & KNITTED CUFFS

A Reinforced Spunbond Polypropolyene with Coated Polyethylene.

- Latex Free
- A Reinforced Chest, Torso, & Elbow For Additional Protection
- Serged Seams Provide Durability to withstand Fluid Protection
- yet Gown is Breathable for Extended Wear
- Ties at Waist and Neck Line for a Secure Fit
- Designed with a Closed Back
- Color: Blue

CAT NO.	SIZE	QTY
11-1950	UniSize	50/Case



## TYVEK® 17" BOOT COVERS, NON-SKID

- Elastic Top Boot Cover
- Serged Seams, Non-Skid Material
- Meets ANSI/ISEA 101-1996 Specifications

CAT NO.	SIZE	QTY
13-1801	Uni-Size	100 Pairs/Case
13-1803	Uni-Size, Gray	100 Pairs/Case
13-1805	Uni-Size, Gray	50 Pairs/Case



## GENPRO™ HEAT SEALED SEAMS

- Moderate Fluid Barrier
- Elastic Cuff, Snug Fit
- Adhesive Sole

CAT NO.	SIZE	QTY
35-1820	Uni-Size, BLUE	150 Pairs/Case
35-1823	XLarge, BLUE	150 Pairs/Case



## CPE SHOE COVERS

Fluid resistant performance and great dry surface traction.

- Ideal for critical environments, material reduces contamination entering your work areas.
- Comfortable to wear during any work activity

CAT NO.	SIZE	QTY
13-1854	XL, White	500 Pair/Case
13-1854B	XL, Blue	500 Pair/Case



## AQUATRAK® SHOE COVERS

Sonic Welded Seamless Sole, FLUID IMPERVIOUS

- Sonic Welded Seamless Sole Shoe Covers
- Fluid Impervious in Material and Construction
- Seamless Sole for Added Comfort
- Elastic In Sole Provides Added Traction, Snug Fit

CAT NO.	SIZE	QTY
35-1885	Uni-Size, WHITE	75 Pair/Case
35-1886	XLarge, WHITE	75 Pair/Case
35-1887	Uni-Size, WHITE	75 Pair/Case
35-1888	XLarge, WHITE	75 Pair/Case
35-1889	2XLarge, WHITE	75 Pair/Case
35-1887B	Uni-Size, BLUE	75 Pair/Case
35-1888B	XLarge, BLUE	75 Pair/Case
35-1889B	2XLarge, BLUE	75 Pair/Case





## AQUATRAK® BOOT COVERS, Ankle High, Serged Seams

For DRY Conditions or Light Surface Wetness

- Elastic Seams Provide Secure Closure, Snug Fit
- Color Coded by Size for Easy Identification

CAT NO.	SIZE	QTY
35-1934B	XLarge, BLUE	100 Pair/Case
35-1934BL	2XLarge, BLACK	100 Pair/Case



## AQUATRAK® BOOT COVERS, Ankle High, IMPERVIOUS

Sonic Welded Seamless Sole

- Fluid Impervious in Material and Construction
- Ankle Ties for a Snug Fit, Ankle High
- A Seamless Sole for Comfort and Traction
- Elastic Top ensures Closure and Support

CAT NO.	SIZE	QTY
35-1910	Uni-Size, BLUE	100 Pairs/Case
35-1912	XLarge, BLUE	100 Pairs/Case

## BOOT COVERS, Knee High, Non Skid

- Breathable, fluid-resistant Multilayer material above and fluid-resistant polypropylene coating below the ankle for effective fluid protection
- Excellent traction and increased stability with special tread on the bottom
- Heat-sealed seams help reduce risks of fluid penetration
- Knee-high design

CAT NO.	SIZE	QTY
35-1900	Uni-Size, BLUE	75 Pairs/Case
35-1902	XLarge, BLUE	75 Pairs/Case





**SHOE PROTECTION**

Non Skid Material Reduces Slips and Falls  
 Excellent for Dry Conditions  
 A Combination of Traction, Durability and Cleanliness

**SHOE COVERS, SERGED SEAMS, Non-Conductive**

Serged seams for added strength, traction and a snug fit for safety; unique conductive shoe cover for those environments where electro-static dissipation (ESD) protection is required

CAT NO.	SIZE	QTY
35-1850	Uni-Size, BLUE	150 Pair/Case
35-1851	XLarge, BLUE	150 Pair/Case
35-1852	2XLarge, BLUE	150 Pair/Case

**SHOE COVERS, SERGED SEAMS, Conductive For Dry Conditions**

- Conductive Strip Meets NFPA 99 ESD Requirements, Tucks into Sock to Provide a Path to Grounds
- Anti-Shock, ESD Protective

CAT NO.	SIZE	QTY
35-1900	Uni-Size, BLUE	75 Pairs/Case
35-1902	XLarge, BLUE	75 Pairs/Case



**VOLUME DISCOUNTS AND CONTRACT PRICING AVAILABLE**

## BOOT & SHOE PROTECTION

Designed for Long Wear  
Will not Leave Residue on any Floors  
For Dry or Damp Environments

ULTRAGRIP™ The Ultimate in Slip & Fall Protection, Designed to withstand the most Abrasive Floor Surfaces

### SHOE COVERS, Serged Seams, BarrierTech® UltraGrip™

The Ultimate in Safety, Material is a Barrier to Fluids, Particulates & Limited Light Chemical Splash

CAT NO.	SIZE	QTY
35-1926	Medium, White	100 Pair/Case
35-1927	Large, White	100 Pair/Case
35-1928	Uni-Size, White	100 Pair/Case
35-1929	XLarge, White	100 Pair/Case
35-1926B	Medium, Blue	100 Pair/Case
35-1927B	Large, Blue	100 Pair/Case
35-1928B	Uni-Size, Blue	100 Pair/Case
35-1929B	XLarge, Blue	100 Pair/Case



### Boot Covers, Elastic Top, Ankle Ties Microbreathe™, UltraGrip™

A Fluid & Particulate Barrier with an Amazing Water Vapor Transmission Rate That will Keep you Comfortable.

- Performs Well in Both Dry & Wet Conditions
- Protects your Employees & Your Environment
- Anti-Skid Sole will Eliminate Accidents
- Elastic Top, Ankle Ties

CAT NO.	SIZE	QTY
35-1940	Medium, White	100 Pair/Case
35-1941	Medium, White	100 Pair/Case
35-1942	XLarge, White	100 Pair/Case
35-1943	Uni-Size, White	100 Pair/Case



### Boot Covers, Elastic Top & Ankle Microbreathe™, UltraGrip™

CAT NO.	SIZE	QTY
35-1941E	Medium, White	100 Pair/Case
35-1942E	XLarge, White	100 Pair/Case
35-1943E	Uni-Size, White	100 Pair/Case

## NITRILE GLOVES, Powder Free

Nitrile gloves have excellent barrier protection and abrasion resistance. Aloe coating soothes and protects hands. Comfortable fit with textured grip. Approved for use with Chemotherapy Drugs.

- Meets or exceeds ASTM D3578
- 1,000 / Case, 10 Boxes / 100

CAT NO.	SIZE
16-2740	X-Small, Green
16-2741	Small, Green
16-2742	Medium, Green
16-2744	Large, Green
16-2745	X-Large, Green



## VersaShield Extended Cuff Powder-Free Nitrile Exam Gloves

- VersaShield gloves offer dependable strength you can count on and have a long 12"; cuff that helps provide an extra barrier for your wrists and arms; textured fingertips provide enhanced grip
- Barrier tested against fentanyl exposure up to 240 minutes to help protect you when treating overdose patients (permeation testing per ASTM D6978-05)
- Chemical tested to ASTM F739-12\*
- Meets both ASTM D6978-05 and USP 800 Personal Protection Equipment requirement for use of chemotherapy gloves when handling hazardous drugs\*\*
- Meet standards of the National Fire Protection Association (NFPA)\*\*\*
- 500 / Case/10 Boxes / 50

CAT NO.	SIZE
16-2741X	Small, Blue
16-2742X	Medium, Blue
16-2744X	Large, Blue
16-2745X	X-Large, Blue



## CURAD Powder-Free Textured Latex Exam Gloves

- CURAD powder-free latex exam gloves have excellent barrier properties combined with great fit and feel
- The textured surface helps ensure a secure grip
- Superior elasticity provides exceptional comfort and strength
- 1,000/Case, 10 Boxes/100
- X-Large: 900/Case, 9 Boxes/100

CAT NO.	SIZE
16-1000	X-Small, White
16-1001	Small, White
16-1002	Medium, White
16-1003	Large, White
16-1004	X-Large, White



## CHEMO NITRILE LATEX FREE POWDER FREE GLOVES

Nitrile gloves conform to the shape of the hand. Gloves have excellent tactile sensitivity with high tensile strength for durable barrier protection. Tight cuffs to minimize exposure, textured for a better grip. Approved for use with Chemotherapy Drugs, Formaldehyde, Gluteraldehyde.

- Meets or exceeds ASTM D3578
- 1,000 / Case, 10 Boxes / 100

CAT NO.	SIZE
16-1061	Small
16-1062	Medium
16-1063	Large
16-1064	X-Large



## Ansell Touch N Tuff® ECONOMY TEXTURED, NITRILE GLOVES

Touch N Tuff Durable disposable nitrile gloves with textured fingers for improved grip. Gloves are static dissipative.

- APPLICATIONS: Laboratory analysis/Technical work
- 1,000 / Case, 10 Boxes / 100
- COLOR: Blue

CAT NO.	SIZE
16-1071	Small, Powder Free
16-1072	Medium, Powder Free
16-1073	Large, Powder Free
16-1074	X-Large, Powder Free
16-1076	Small, Lightly Powdered
16-1077	Medium, Lightly Powdered
16-1078	Large, Lightly Powdered
16-1079	X-Large, Lightly Powdered



## Touch N Tuff® POWDERED DISPOSABLE GLOVES

100% Natural Rubber Latex, lightly powdered with absorbable cornstarch for easy donning. Gloves have excellent dexterity along with strength and comfort.

- LENGTH: 9.5"
- APPLICATIONS: Laboratory analysis/Technical work
- 1,000 / Case, 10 Boxes / 100

CAT NO.	SIZE
16-1091	Small, White
116-1091	Medium, White
16-1091	Large, White
16-1091	X-Large, White



## SAFEGRIP® Exam Gloves LATEX, POWDER FREE

Extended beaded cuff for protection over the wrist and arm. Thicker fingertips for additional protection in high risk situations. Excellent for hazardous environments.

- Length: 11.8"
- Finger: 16.5mil Hand: 11.4mil Cuff: 9.7mil
- 500 / Case, 10 Boxes / 50

CAT NO.	SIZE
16-1151	Small
16-1152	Medium
16-1153	Large
16-1154	X-Large



## Diamond Grip™ NATURAL LATEX, POWDER FREE

Natural rubber latex examination glove, tough and reliable. Provides durability and comfort. Textured fingertips excellent for dry or wet conditions.

- Length: 9.8"
- Finger: 9.1mil Hand: 6.3mil Cuff: 5.1mil
- 1,000 / Case, 10 Boxes / 100

CAT NO.	SIZE
16-1131	Small
16-1132	Medium
16-1133	Large
16-1134	X-Large



## ComfortGrip™ LATEX, POWDER FREE GLOVES

Low protein natural rubber latex, offers elasticity and barrier integrity to promote comfortable protection.

- Length: 9.6"
- Finger: 5.9mil Hand: 5.1mil Cuff: 3.9mil
- 1,000/Case, 100/Box

CAT NO.	SIZE
16-1121	Small
16-1122	Medium
16-1123	Large
16-1124	X-Large





## FitGuard Touch Powder-Free Nitrile Exam Gloves

- Sensitive nitrile gloves designed to combine tactile feel with durable nitrile protection and textured fingertips for enhanced grip
- Color-coded sizing helps quickly identify right size
- FitGuard Touch Nitrile Gloves (FG3002 series and FG100M series) use Zinc Di-n-butylidithiocarbamate (ZDBC), a carbamate accelerator
- Meets USP 800 Personal Protection Equipment requirement for use of chemotherapy gloves when handling hazardous drugs\*

\* When used in accordance to the guidelines set forth in the USP 800 chapter. Tested chemotherapy drugs available upon request. Do not use with Carmustine and Thiotepa.

- 1000/Case, 10 Boxes/100

CAT NO.	SIZE
16-FG100	Small
16-FG102	Medium
16-FG104	Large
16-FG106	X-Large



## Ansell Microflex Midnight® NITRILE GLOVES

MidKnight gloves are designed with a distinctive black color that masks stains and provides improved framing effect. This is the glove of choice for individuals who demand both quality and protection against day-to-day hazards.

- Length: 9.6"
- Finger: 6.0mil Hand: 4.7mil Cuff: 3.1mil
- 1,000/Case, 10/Box

CAT NO.	SIZE
16-1296	Large



## Ansell Microflex Evolution One® Powder-Free Latex Exam Gloves

Made with premium latex, Evolution One® gloves provide maximum comfort along with enhanced tactile sensitivity. Strong and durable with a secure grip, Evolution One® gloves slip on easily, wet or dry, and provide a consistent performance in mid-range environments.

- 1000/Case, 10 Boxes/100

CAT NO.	SIZE
16-1250	Small
16-1252	Medium
16-1254	Large
16-1256	X-Large

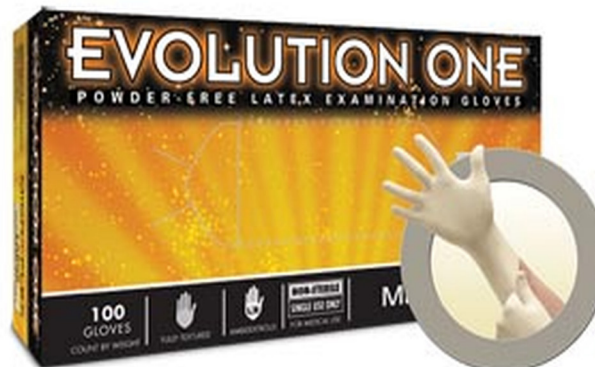



**Ansell Canners and Handlers™ GLOVES**

Canners gloves can be used for autopsy and embalming. Natural Latex, (Natural Rubber Latex May Cause Allergic Reactions) excellent dexterity, tensile strength and elasticity, An Excellent Choice, Fishscale pattern for Better Grip in Dry/Wet Conditions

**CHEMICAL RESISTANCE:**

Acid, Detergents, Salts, Caustic, Animal Fats, Vegetable Oils and Alcohols, Abrasion and Tear Resistance

**FEATURES/BENEFITS:**

20 Mil Natural unsupported  
Latex, Excellent Chemical, Abrasion and Tear Resistance

- LENGTH: 12"
- COLOR: Natural
- QUANTITY: 12 Pairs / Pack

CAT NO.	SIZE
17-3912	7
17-3914	8
17-3916	9
17-3918	10

**The GAUNTLET STAINLESS STEEL GLOVE**

Gloves have Stainless Steel Individual, interlocking rings providing a remarkable sense of touch while securely protecting the users hand. Gloves are designed for optimal comfort and fit.

**SPECIFICATIONS**

- Easy to Clean and Hygienic
- Full Hand Coverage
- Polypropylene Fiber Strap

**APPLICATIONS**

- Autopsy/Post Mortem Use
- Food Processing
- Veterinary Service
- Manufacturing Industries

CAT NO.	SIZE
15-2820	XSmall
15-2821	Small
15-2822	Medium
15-2823	Large
15-2824	X-Large
15-2825	XX-Large



## KUT-GARD® PROTECTION

Fiber Steel, an advanced stainless steel fiber that offers all the performance advantages of steel wire without the stiffness or wire end irritation, combined with highly abrasion resistant thermoplastic fibers in an engineered yarn. Alternative to most wire and non-wire gloves, featuring outstanding cut and abrasion protection, combined with exceptional wear for a longer service life. Offers excellent grip and is soft and flexible enough to be worn for long periods of time.

A finer gauge version which features an extraordinarily high degree of dexterity, comfort and fit, while still providing excellent cut and abrasion protection.

Gloves are thin and flexible enough to be worn under other gloves as a protective liner or on its own as a highly ergonomic alternative to heavier gloves, without having to sacrifice protection.

**WARNING: Kut-Gard Products are Not Recommended for use with Serrated or Moving Blades.**

## SPECIFICATIONS:

- Fully Reversible
- Seamless Knit Construction
- Flexible and Comfortable
- 3" Cuff w/ Non-metallic Wrist Band Prevents Wrist Irritation
- Pre-Shrunk Sizes Assure Fit after Laundering
- Color-Coded Hems Indicate Size
- Meets FDA & USDA Food Handling Requirements

## APPLICATIONS:

- Autopsy/Post Mortem Use
- Food Processing
- Military Installations
- Foundries

## KUT-GARD® II GLOVES

- 7 Gauge Fiber Steel Core
- Machine washable. Complies with FDA & USDA Regulations.
- COLOR: White with Color Coded Size Band
- QTY: 1 Glove / Individual Pack

CAT NO.	SIZE
13-2940	XLarge, Green
13-2942	Large, White
13-2944	Medium, Blue
13-2946	Small, Yellow
13-2948	XSmall, Black



## KUT-GARD® II LITE GLOVES

- 10-Gauge Fiber Steel Core
- Machine washable. Complies with FDA & USDA Regulations.
- COLOR: White with Color Coded Size Cuff
- QTY: 1 Glove / Individual Pack

CAT NO.	SIZE
13-2960	XLarge, Green
13-2962	Large, White
13-2964	Medium, Blue
13-2966	Small, Yellow
13-2968	XSmall, Black



### PATTERN DESIGN

Patent No. 6,004,034

Our Innovative Salam Pattern Design Eliminates Sewing and Welding on the Length Sides. This Increases the Strength with Absolutely No Leakage. GUARANTEED

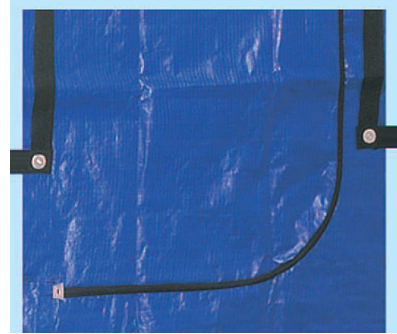

### BAG TAG/LOCK

Patent No. 6,112,383

With Our New Bag Tag/Lock, Our Salam Pouches will not tear at the end of the zipper. GUARANTEED



### WELDING

An Innovative Application of High Frequency Welding Ensures that Our Pouches are the Strongest. Salam Pouches are Completely leak proof on all sides. GUARANTEED



### ZIPPER WITH 2-SLIDERS

Salam Pouches have #5, #7 and #10 Heavy-Duty Zippers, with 2 Sliders/Pulls for Easy Opening and Easy Securing of Evidence with Lock. GUARANTEED



### RIVETS

Salam Heavy-Duty Rivets and Fender Washers Ensure that webbing and handles are fastened to the pouch with more than adequate strength. GUARANTEED



## FEATURES OF DISASTER POUCHES



Impervious to Blood, Body Fats, Chemicals and Fluids

Low Odor Detection, Mildew/Temperature Resistant

Best Quality, Puncture/Tear Resistant, Packed in Poly Bag

### ECONOMY

Our Economical Vinyl Pouch, 5-6 mil, Pattern Design (Patent No. 6,004,034) & Bag Tag/Lock (Patent No. 6,112,383), Tear resistant, Heavy-Duty #5 Zipper, 2 Large Lockable Sliders/Pulls for easy opening and securing. Completely Leak proof from all sides.

### HEAVY VINYL POUCH

Our Thicker, Heavy Vinyl Pouch, 7-9 mil, Pattern Design (Patent No. 6,004,034) & Bag Tag/Lock (Patent No. 6,112,383), Tear resistant, Heavy-Duty #7 Zipper, 2 Large Sliders/Pulls for easy opening and securing. Completely Leak proof from all sides.

### MEDIUM WEIGHT POUCH

Our Low Cost Pouch, Pattern Design (Patent No. 6,004,034) & Bag Tag/Lock (Patent No. 6,112,383), Tear resistant, Heavy Duty #7 Zipper, 2 Large Sliders/Pulls for easy opening and securing. The strongest pouch in its class. CHLORINE FREE

### SUPER MEDIUM WEIGHT POUCH

Made with Super Strong Material, Pattern Design (Patent No. 6,004,034) & Bag Tag/Lock (Patent No. 6,112,383), Tear resistant, Heavy Duty #10 Zipper, 2 Large Sliders/Pulls for easy opening and securing. A very strong pouch. CHLORINE FREE

### HEAVY DUTY WEIGHT POUCH

Our Strongest Pouch Yet, Pattern Design (Patent No. 6,004,034) & Bag Tag/Lock (Patent No. 6,112,383), Tear resistant, Heavy Duty #10 Zipper, 2 Large Sliders/Pulls for easy opening and securing. High Frequency Welded for strength. Completely Leak proof from sides.



## ECONOMY VINYL DISASTER POUCHES

### A Heavier Yet Much Softer Material

- 5-6 mil Vinyl
- A Longer Heavy Duty # 5 Zipper
- (2 Way) Zipper with 2 sliders that allows pouch to be opened & closed at any point
  - 2 Large Lockable pulls to secure pouch
  - A wider envelope opening
- No sewing or welding on length sides eliminating any leaks and increasing strength,
  - Ends are High Frequency Welded
  - Opaque White

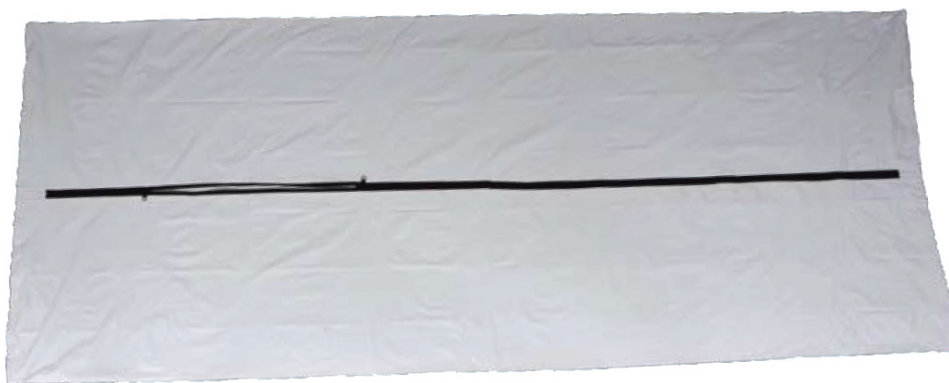

PATTERN DESIGN (Patent No. 6,004,034) & BAG TAG/LOCK (Patent No. 6,112,383)

### ABSOLUTELY NO LEAKAGE FROM SIDES

\*Does not include zipper area.

CAT NO.	SIZE	STYLE
11-122	Adult 90" x 36"	Center Zipper
11-124	Adult 90" x 36"	Envelope Zipper

**OVER 150,000 POUCHES IN STOCK OR IN PRODUCTION AT ANY GIVEN TIME**

**VOLUME DISCOUNTS & CONTRACT PRICING AVAILABLE**

## ENVIRONMENTALLY FRIENDLY DISASTER POUCH Heavy Duty Superior Strength

A Unique Material Co-Extruded by ETHYLENE COPOLYMER mix with 3 Layers of C4, C6, and C8 Respectively. That is why the Material is so Strong. Chlorine Free. Complies with OSHA Regulation 3130 involving Containment of Body Fluids, Impervious to Blood, Body Fats, Chemicals and Fluids, CHLORINE -FREE Burn Requirement

- A Heavy Duty # 7 Zipper
- (2 Way) Zipper with 2 Sliders that Allows Pouch to be Opened & Closed at Any Point
  - 2 Large Lockable Pulls to Secure Pouch
  - A wider envelope opening
- No Sewing or Welding on Length Sides Eliminating Any Leaks and Increasing Strength
  - Ends are High Frequency Welded
  - OPAQUE WHITE



**\*THIS POUCH IS 100% LEAK PROOF\***

\*Does not include zipper area.

CAT NO.	SIZE	STYLE
11-384	Adult 94" x 36"	Envelope Zipper

**VOLUME DISCOUNTS & CONTRACT PRICING AVAILABLE**



## HEAVY VINYL DISASTER POUCHES

A Heavier Yet Much Softer Material

### ABSOLUTELY NO LEAKAGE FROM SIDES

- 7-9 mil Vinyl
- A Heavier yet much softer material
  - Heavy Duty # 7 Zipper
- (2 Way) Zipper with 2 sliders that allows pouch to be opened & closed at any point
  - 2 Large Lockable pulls to secure pouch
  - Wider envelope opening
- No sewing or welding on the length sides eliminating any leaks and increasing strength
  - Ends are High Frequency Welded
  - Opaque White and Yellow



PATTERN DESIGN (Patent No. 6,004,034) & BAG TAG/LOCK (Patent No. 6,112,383)

### ABSOLUTELY NO LEAKAGE FROM SIDES

\*Does not include zipper area.

CAT NO.	SIZE	STYLE	COLOR
11-202	Adult 94" x 36"	Center Zipper	White, Yellow
11-204	Adult 94" x 36"	Envelope Zipper	White
11-206	Pediatric 48" x 24"	Envelope Zipper	White, Yellow
11-208C	Infant 24" x 12"	Center Zipper	White, Yellow

**OVER 150,000 POUCHES IN STOCK OR IN PRODUCTION AT ANY GIVEN TIME**

## MEDIUM WEIGHT DISASTER POUCHES HDPE Specially Woven Coated Tarpaulin, A Heavier, Thicker Material

- Heavy Duty # 7 zipper
- 2 Way) Zipper with 2 sliders that allows pouch to be opened & closed at any point
  - 2 Lockable pulls to secure pouch
  - HDPE Specially woven coated tarpaulin, A Heavier & thicker material
- No sewing or welding on length sides eliminating leaks and increasing strength
  - Handles secured by Heavy Duty Rivets
    - 2" Wide webbing for easy grab
    - Handle straps run under pouch
- Additional side straps allow lifting by only 2 people or helicopter without sagging
  - Available in Blue & White

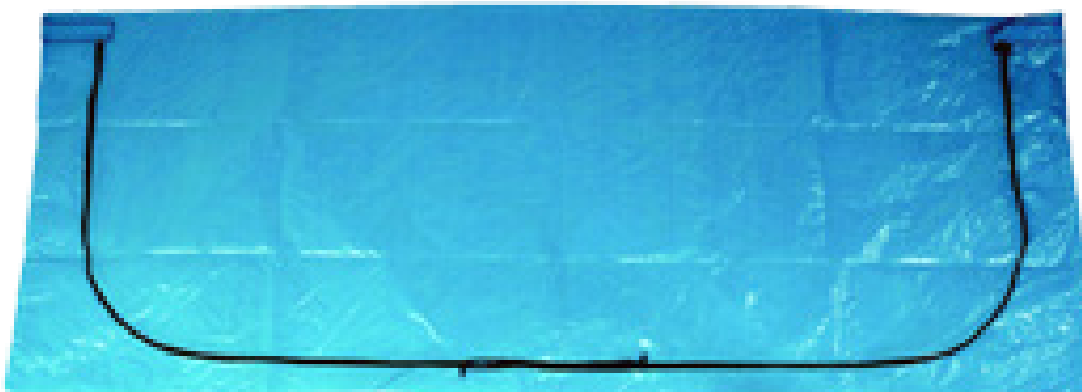

PATTERN DESIGN (Patent No. 6,004,034) & BAG TAG/LOCK (Patent No. 6,112,383)

Complies with OSHA Regulation 3130 involving Containment of Body Fluids, Impervious to Blood, Body Fats, Chemicals and Fluids, **CHLORINE -FREE** Burn Requirement

CAT NO.	SIZE	STYLE	HANDLES	COLOR
11-222	Adult 94" x 36"	Center Zipper	No	Blue, White
11-224	Adult 94" x 36"	Envelope Zipper	No	Blue, White
11-226	Pediatric 48" x 24"	Envelope	No	Blue, White
11-228C	Infant 24" x 12"	Center	No	Blue, White
11-242	Adult 94" x 36"	Center Zipper	4 Handles	Blue
11-244	Adult 94" x 36"	Envelope Zipper	4 Handles	Blue
11-232	Adult 94" x 36"	Center Zipper	6 Handles	Blue
11-234	Adult 94" x 36"	Envelope Zipper	6 Handles	Blue

## SUPER MEDIUM WEIGHT DISASTER POUCHES HDPE Specially Woven Tarpaulin

- A Heavy Duty #10 zipper
- (2 Way) Zipper with 2 sliders that allows pouch to be opened & closed at any point
  - Heavier & thicker material
- Handles secured by Heavy Duty Rivets
  - 2 Lockable pulls to secure pouch
    - A wide Envelope Opening
  - Handle straps run under pouch
- Additional side straps allow lifting by only two people or Helicopter without sagging
- No sewing or welding on length sides eliminating any leaks and increasing strength
  - Ends are High Frequency Welded
    - Dark Blue



PATTERN DESIGN (Patent No. 6,004,034) & BAG TAG/LOCK (Patent No. 6,112,383)

Complies with OSHA Regulation 3130 involving Containment of Body Fluids, Impervious to Blood, Body Fats, Chemicals and Fluids, **CHLORINE -FREE** Burn Requirement

CAT NO.	SIZE	STYLE	HANDLES
11-332	Adult 94" x 36"	Center Zipper	No
11-334	Adult 94" x 36"	Envelope Zipper	No
11-322	Adult 94" x 36"	Center Zipper	6 Handles
11-324	Adult 94" x 36"	Envelope Zipper	6 Handles
SUPER LARGE POUCH SIZE			
11-354	Adult 94" x 46"	Envelope Zipper	6 Handles

## HEAVY DUTY DISASTER POUCHES SIMPLY THE STRONGEST POUCH IN THE MARKET

- Heavy Duty #10 Zipper
- (2 Way) Zipper with 2 large sliders that allows pouch to be opened & closed at any point
  - 2 Lockable pulls to secure pouch
    - Innovative High Frequency
    - Welding for strength
  - Absolutely no leakage from all sides
- No sewing or welding on length sides eliminating any leaks and increasing strength
  - Handles secured by Heavy Duty rivets
    - 2" Wide webbing for easy grab
    - Handle straps run under pouch
- Additional side straps on each side allow lifting by only 2 people or helicopter without sagging
  - Not affected by temperature extremes
    - Available in ORANGE & BLACK



PATTERN DESIGN (Patent No. 6,004,034) & BAG TAG/LOCK (Patent No. 6,112,383)

**ABSOLUTELY NO LEAKAGE FROM SIDES**

\*Does not include zipper area.

CAT NO.	SIZE	STYLE	COLOR	HANDLES
11-504	Adult 94" x 36"	Envelope Zipper	Black	6 Handles
11-514	Adult 94" x 36"	Envelope Zipper	Orange	6 Handles

**VOLUME DISCOUNTS & CONTRACT PRICING AVAILABLE**

## JUMBO SUPER HEAVY DUTY POUCH

SIZE: 54" x 108"

HDPE Specially Woven Coated Tarpaulin, A Heavier, Thicker Material

- Heavy Duty #10 Zipper
- (2 Way) Zipper with 2 Large Sliders that Allows Pouch to be Opened & Closed at any Point
  - 2 Lockable Pulls to Secure Pouch
  - HDPE Specially Woven Coated Tarpaulin
- No Sewing or Welding on Length Sides Eliminating Any Leaks and Increasing Strength
  - Handles Secured by Heavy Duty Rivets
    - 2" Wide Webbing for Easy Grab
    - Handle Straps Run Under Pouch
  - Not Affected by Temperature Extremes
    - DARK BLUE



PATTERN DESIGN (Patent No. 6,004,034) & BAG TAG/LOCK (Patent No. 6,112,383)

**ABSOLUTELY NO LEAKAGE FROM SIDES**

Complies with OSHA Regulation 3130 involving Containment of Body Fluids, Impervious to Blood, Body Fats, Chemicals and Fluids, **CHLORINE -FREE** Burn Requirement

CAT NO.	SIZE	STYLE	COLOR	HANDLES
11-364	Adult 108" x 54	Envelope Zipper	Dark Blue	10 Handles



## NEXT GENERATION HEAVY DUTY POUCH

**PVB Woven Coated Tarpaulin Material With Additional Tensile Strength, Same Material that Prevents Safety Glass Shattering**

**(PVB) Burns Without Black Smoke and Toxin Dioxin, Unlike Most Conventional Pouches**

- (2 Way) Zipper with 2 large sliders that allows pouch to be opened & closed at any point
  - 2 Lockable pulls to secure pouch
  - Innovative High Frequency Welding for strength
    - Absolutely no leakage from all sides
    - Handles secured by Heavy Duty rivets
    - 2" Wide webbing for easy grab
    - Handle straps run under pouch
- Additional side straps on each side allow lifting by only 2 people or helicopter without sagging
  - Not affected by temperature extremes
    - Available in OLIVE GREEN



**\*THIS POUCH IS 100% LEAK PROOF\***  
**\*DOES NOT INCLUDE ZIPPER AREA.**

CAT NO.	SIZE	STYLE	COLOR	HANDLES
11-604	Adult 36" x 92"	Envelope Zipper	Olive Green	6 Handles

**OVER 150,000 POUCHES IN STOCK OR IN PRODUCTION AT ANY GIVEN TIME**



## WATER RECOVERY DISASTER POUCH FLOATER RETRIEVER

Not Affected by Saltwater or Temperature Extremes

- Heavy Duty #10 Zipper
  - Oversize zipper pull for easy grab
- Top of Case is CONCEALED for PRIVACY
- Handles Secured by Heavy Duty Rivets
  - 2" Wide Webbing for EASY GRAB
  - Handle Straps Run Under Pouch
    - Easy to Lift Into Boat
- (2 Way) Zipper with 2 Large Sliders That Allows Pouch to be Opened & Closed at Any Point
  - 2 Lockable Pulls to Secure Pouch
- HDPE Specially Woven Coated Tarpaulin
- No Sewing or Welding on Length Sides Eliminating any Leaks and Increasing Strength
  - 2" Wide Webbing for EASY GRAB
    - Reusable
    - Yellow

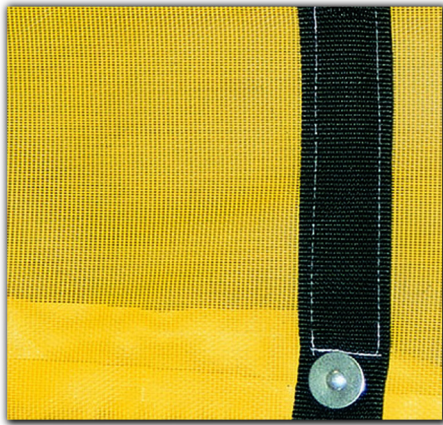

CAT NO.	SIZE	STYLE	COLOR	HANDLES
11-135	Adult 94" x 36"	Envelope Zipper	YELLOW	6 Handles

### CREMATION POUCH

- Complies with OSHA Regulation 3130
  - Chlorine Free Burn Requirement.
    - 100% Leakproof
    - Made with 4mil PE Material
    - High Frequency Welded
  - A Longer Heavy Duty #3 Zipper
- Complies with OSHA Regulation 3130 Involving Containment of Body Fluids, Impervious to Blood, Body Fats, Chemicals and Fluids
  - Sold in Packs of 6
  - OPAQUE WHITE



CAT NO.	SIZE	STYLE	QUANTITY
11-112	Adult 90" x 36"	Center Zipper	6 per Pack

## SHROUDS

Ends of the Shroud are Heat-Sealed. Shroud is Shaped Like a Canoe for Easier, Safer Handling During Transportation

- Heavy Duty Polyethylene
- Extra Large DISPOSABLE Sheets
- Aids with Leakage Problems
- May be used as a Protective Liner for Body Pouches
- Protects Linen on Removal Cots
- Complies with OSHA Regulation 3130 involving Containment of Body Fluids, Impervious to Blood, Body Fats, Chemicals and Fluids, CHLORINE -FREE Burn Requirement
- OPAQUE WHITE



CAT NO.	DESCRIPTION	QTY
11-860	65" x 113", 0.12 mm (5 mil)	25 / Box
11-862	65" x 113", 0.08 mm (3.1 mil)	50 / Box

## SHROUD PACK

CAT NO.	DESCRIPTION	QUANTITY
11-856	72" x 108" (7 mil)	i Sheet
	1/4" x 36" Twill Tape	2 PCS
	1/4" x 60" Twill Tape	2 PCS
	3/16" x 36" Nylon Solid Braid	2 PCS
	3/16" x 72" Nylon Solid Braid	2 PCS
	Toe Tag	3 PCS

## WRAPPING SHEETS

Protective Liner for Body Pouches and Removal Cots

- Heavy Duty Polyethylene Extra Large DISPOSABLE Sheets
- Aids with Leakage Problems
- May be used as a Protective Liner for Body Pouches Protects Linen on Removal Cots
- Complies with OSHA Regulation 3130 involving Containment of Body Fluids, Impervious to Blood, Body Fats, Chemicals and Fluids, CHLORINE -FREE Burn Requirement
- OPAQUE WHITE

CAT NO.	DESCRIPTION	QTY
11-850	65" x 113", 0.12 mm (5 mil)	25 Sheets / Roll
11-852	65" x 113", 0.08 mm (3.1 mil)	50 Sheets / Roll



## VISCERA BAGS

Chem-Proof, TEAR RESISTANT Bags Will Preserve Contents Better and Longer

- Made with 4mil Polyethylene Sheeting
- Securely Holds Chemically Treated Organs
- Aids with Leakage Problems
- Strong Ties
- Complies with OSHA Regulation 3130 involving Containment of Body Fluids, Impervious to Blood, Body Fats, Chemicals and Fluids, CHLORINE -FREE Burn Requirement

CAT NO.	DESCRIPTION	QUANTITY
11-830	24" x 24", 0.10 mm (4 mil)	50 / Box
11-840	20" x 30", 0.10 mm (4 mil)	50 / Box

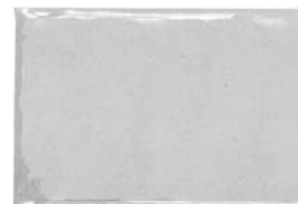

**SENTRY SUPERBAND POLY WRITE ON ID BANDS**

- Lightweight Non-Stretch Polyester
- Patented SecurSnap® closure provides maximum security
- Special ClearImage® surface protects handwritten and embossed information



- QTY: 500/Box

CAT NO.	COLOR	DIMENSIONS
62-9300	Orange	Adult, L 11 1/2" x H 1"
62-9302	Green	Adult, L 11 1/2" x H 1"
62-9304	Yellow	Adult, L 11 1/2" x H 1"
62-9306	Red	Adult, L 11 1/2" x H 1"
62-9308	Blue	Adult, L 11 1/2" x H 1"
62-9310	Pink	Adult, L 11 1/2" x H 1"
62-9312	Purple	Adult, L 11 1/2" x H 1"

**SENTRY SUPERBAND IMPRINTER ID BANDS**

- Lightweight Non-Stretch Polyester
- SPatented SecurSnap® closure provides maximum security
- Special ClearImage® surface protects handwritten and embossed information
- Water-resistant



- QTY: 500/Box

CAT NO.	COLOR	DIMENSIONS
62-9320	White	Adult, L 11 1/2" x H 1"
62-9321	Blue	Adult, L 11 1/2" x H 1"
62-9322	Yellow	Adult, L 11 1/2" x H 1"
62-9323	Red	Adult, L 11 1/2" x H 1"
62-9324	Orange	Adult, L 11 1/2" x H 1"
62-9325	Green	Adult, L 11 1/2" x H 1"

**TOE TAGS**

Ideal for Cadaver Identification

- Easy Write
- Aids with Quick ID
- Elastic Band
- SIZE: 3" x 5.5"
- BRIGHT WHITE

CAT NO.	STYLE	QUANTITY
<b>11-870</b>	Card Stock	100/ Pack
<b>11-870PP</b>	Polypropylene	100/ Pack

I.D. TAG

DECEASED \_\_\_\_\_ DATE \_\_\_\_\_

PLACE OF DEATH \_\_\_\_\_

TRANSPORTED BY \_\_\_\_\_

PROPERTY TAKEN \_\_\_\_\_

PROPERTY LOCATION \_\_\_\_\_

CASE NO. \_\_\_\_\_ INVESTIGATOR \_\_\_\_\_

SIGNATURE \_\_\_\_\_

REMARKS/ADDITIONAL INFORMATION - SEE REVERSE SIDE

## SOFT VINYL WRITE ON ID BANDS

- Soft Vinyl
- Snap Closure
- LATEX FREE
- QTY: 250/Box

CAT NO.	COLOR	DIMENSIONS
62-1441	White	Adult, L 4" x H 1"
62-1442	Blue	Adult, L 4" x H 1"
62-1443	Yellow	Adult, L 4" x H 1"
62-1445	White	Pediatric, L 3" x H 3/4"
62-1446	Blue	Pediatric, L 3" x H 3/4"
62-1447	Yellow	Pediatric, L 3" x H 3/4"



## POUCH LOCKS

The Perfect Solution for Securing Evidence

- Alpha Numeric Serial Numbers
- Tamper Proof
- Length: 8.5" (210 mm)

CAT NO.	MATERIAL	QUANTITY
11-892B	BLUE, Plastic	250/ Pack
11-894B	ORANGE, Plastic	250/ Pack
11-896B	YELLOW, Plastic	250/ Pack



## WRITE ON short stay ID BANDS

- Tyvek™, Tamper Evident
- Adhesive Closure
- LATEX FREE
- QTY: 500/Box

CAT NO.	COLOR	DIMENSIONS
62-3000	White	Adult, L 4" x H 1"
62-3002	Blue	Adult, L 4" x H 1"
62-3004	Yellow	Adult, L 4" x H 1"
62-3006	Red	Adult, L 4" x H 1"



**SLAUGHTER FAUCET ADAPTER**

Faucet adapter to a Slip Hub. This adapter will convert a conventional threaded faucet to accept rubber plastic tubing for flushing and washing. Convenient for sink to table use. Chrome.

CAT NO.	DESCRIPTION
12-3202	Threaded to Slip Hub

**WATTS VACUUM BREAKER CAT NO. 12-2140**

Required in most states. Easily connected.

**AUTOPSY SINK STRAINER**

A strainer developed to eliminate the continual stoppage of sink drainage especially during autopsy work. Prevents waistline blockage. Admits trocar for flushing. Need only to be lifted out to cleanse. No screw necessary. Brass chromed.

CAT NO.	DESCRIPTION
12-3300	Large Sink Strainer, FIX 3 3/8" smaller Plate
12-3302	Small Sink Strainer, FIX 1 7/8" smaller Plate

**ELECTRIC NEEDLE INJECTOR**

Power version of the older manual needle injector. Superior control. It is useful for especially hard or soft bones. Very dependable.

CAT NO.	DESCRIPTION
12-3600	Electric Needle Injector

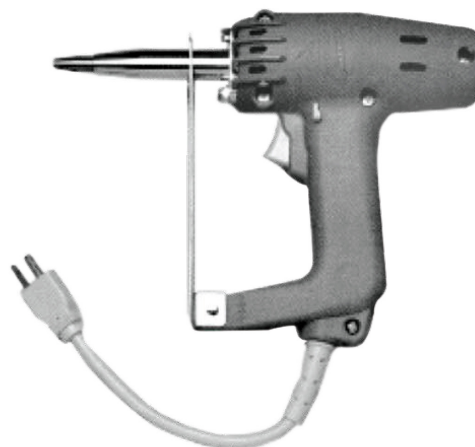
**TUBE DRYING RACK CAT NO. 12-3400**

Made of brass, eliminates molding or kink set in rubber tubing. Permits perfect draining. Keeps tubing in orderly manner. Capacity, 6 lanes. Not pictured.

## NON-CLOGGING POST ASPIRATOR CAT NO. 12-3500

It is designed to completely drain cavities. Its flatness and style of irrigation characterize this item. Upper and lower evacuating surfaces provide non-clogging operation. Full chrome plate and of brass construction. The head can be removed for thorough cleaning.



## POST MORTEM ASPIRATOR

Easy to reach hard-to-reach areas. Aspirates and evacuates fluid material from cavities without the risks posed by use of trocar. Brass, chrome plated.

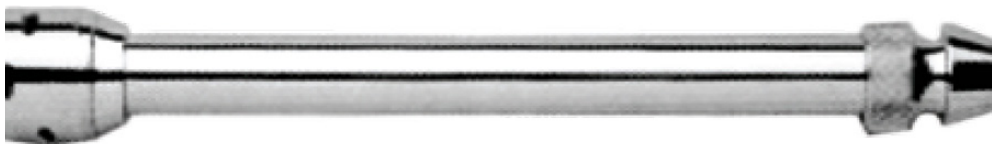

CAT NO.	DESCRIPTION
12-3510	Post Aspirator
12-3512	Post Head Interchangeable With Above

## HYDRO VACUUM TUBE SWIVEL ADAPTER CAT NO. 12-3730

Attaches to 12-3700 Hydro between vacuum tube and Hydro Body for swivel action.

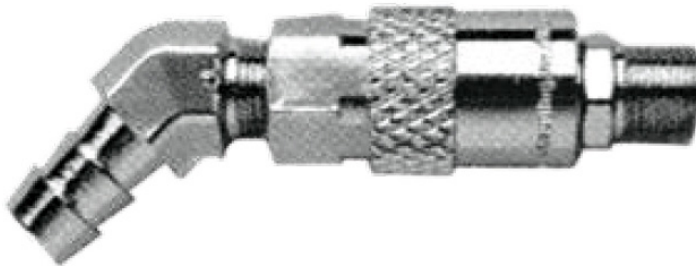



**COMBINATION HYDRO ASPIRATOR CAT NO. 12-3700**

PROVIDES REVERSE FLOW

This Combination Hydro Aspirator's ability to be completely disassembled and cleaned is only one point of its superiority. While the hydro is of the high vacuum type, maintaining a 26" vacuum at 60 pounds water pressure, we advise the use of lower vacuum. A standard trocar is ample to evacuate any body fluids or gases. High vacuum will only collapse the viscera before evacuation is complete and aggravate the clogging of any trocar. We suggest you test hydro and trocar with a vessel of water.

- Solid Brass Chrome Plated Aspirator Completely Disassembles for Easy Cleansing
- Threaded to Fit any Standard Faucet
- A Superior Product in Workmanship and Design
- Unit is Equipped with an Automatic Vacuum Breaker Now Required by Many States As a Safeguard Against Contaminating Water Supply When Pressure Drops
- Aspirator Completely Disassembles for Easy Cleansing
- Maintains a 26 Inch Vacuum at 60 lbs. Water Pressure

**HYDRO ASPIRATOR EXTENSION CAT NO. 12-3710  
REQUIRED BY MANY STATES AS A POLLUTION PRECAUTION**

Doubles protection against water contamination and intensifies aspiration suction. Screws on top of aspirator for instant service. Solid brass chrome plated.

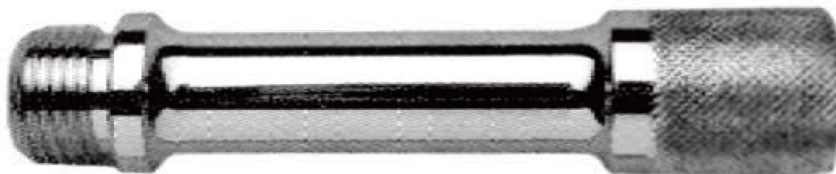

## CLEAR VIEW CAT NO. 12-3720

Operator can see aspirating content before mixing with water, because of the device's large capacity. It is easily kept clean by reversing water valve on hydro.

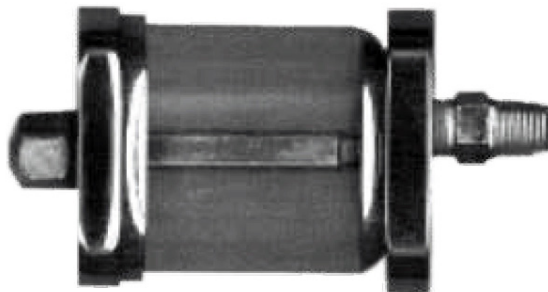

## PURE GUM TUBING



CAT NO.	DESCRIPTION	INNER DIAMETER	OUTER DIAMETER	WALL THICKNESS
12-3800	Trocar Surgical Gum	5/16"	5/8"	5/32"
12-3802	Trocar Clear Vinyl	5/16"	5/8"	5/32"
12-3804	Drain Surgical Gum	5/16"	1/2"	3/32"
12-3806	Drain Clear Vinyl	5/16"	1/2"	3/32"
12-3808	Injection Surgical Gum	1/4"	7/16"	3/32"
12-3812	Hydro Splash Gum	3/4"	1"	1/8"
12-3814	Hydro Splash Clear Vinyl	3/4"	1"	1/8"

## 24-MAXX MORTUARY COT

With its unique, wider surface & independent leg design, the 24-MAXX Heavy Duty Mortuary Cot allows you to transport bodies weighing up to 1,000 pounds. The Cot allows for easy maneuverability in tight areas & down stairs.

The powder coated frame has a stylish design & a variety of innovative features. The 24-MAXX Mortuary Cot offers dependable excellent performance.



CAT NO.	DESCRIPTION
75-2400	24-MAXX Mortuary Cot
75-2402	24-MAXX Mortuary Cot with 1 Pair Side-Lift Handles
75-2404	24-MAXX Mortuary Cot with Side-arms

SPECIFICATIONS	
Length	76" (195.6 cm)
Width	26" (66 cm)
Height	Maximum 40" (102 cm) Minimum 14" (35.5 cm)
Weight	78 lb (35 kg)
Load Limit	1000 lb (450 kg)
Loading Height	Max 26" (66 cm) Min 24" (61 cm)

## 24-MAXX MORTUARY COT

With its unique, wider surface & independent leg design, the 24-MAXX Heavy Duty Mortuary Cot allows you to transport bodies weighing up to 1,000 pounds. The Cot allows for easy maneuverability in tight areas & down stairs.

The powder coated frame has a stylish design & a variety of innovative features. The 24-MAXX Mortuary Cot offers dependable excellent performance.



### FEATURES

- Convenient Dolly Positions
- Independent Controls
- Wheel Locks (Standard on All 24-MAXX Cots)
- Restraints

### OPTIONAL ACCESSORIES

CAT NO.	DESCRIPTION
75-2406	Clamp on Side Arm Kit (24-MAXX/24-miniMax Kit)
75-2408	Side Lift Handles, 1 Pair (24-MAXX/24-miniMax Kit)
75-2409	Replacement 1" (Black) Mattress
75-2410	Cot Cover, Designed for large bodies, Mordex material has Cordura® exterior with a bonded inner liner. Includes a 12" x 14" Pocket • Machine Washable • Burgundy

## 24-MiniMAXX MORTUARY COT

Has all the innovative features of the 24-MAXX in a narrow package. Cot has independent legs with multi-level adjustments, six inch wheels, dual-hand controls, and a distinguished durable gloss-black powder coated finish. 1000lb load capacity allows the cot to handle large bodies with ease. The narrow bed surface gives increased maneuverability and allows two cots to be placed side by side in most rear vehicles.



CAT NO.	DESCRIPTION
75-2420	24-MINIMAXX, Narrow body
75-2422	24-MINIMAXX, Narrow body with side-arms
75-2424	24-MINIMAXX, Narrow body with 1 pair side lift handles

SPECIFICATIONS	
Length	76" (193 cm)
Width	23 5/8" (60 cm)
Height	Maximum 40" (100 cm) Minimum 14" (35 cm)
Weight	76 lb (34 kg)
Load Limit	1000 lb (454 kg)
Loading Height	Max 26" (66 cm) Min 24" (61 cm)



## 24-MiniMAXX MORTUARY COT

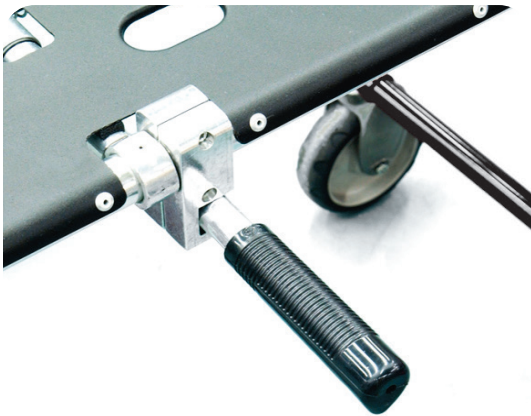

### FEATURES

- Wheel Locks
- Independent Controls
- Side Lift Handles
- Side Rail
- 1 Inch Black Mattress
- 2 Seven Foot Two Piece Black Restraints.

### OPTIONAL ACCESSORIES

CAT NO.	DESCRIPTION
75-2406	Clamp on Side Arm Kit (24-MAXX/24-miniMax Kit)
75-2408	Side Lift Handles, 1 Pair (24-MAXX/24-miniMax Kit)



## Multi Level, One-Man<sup>®</sup> MORTUARY COT

The roll in style cot allows one person to perform retrieval. Special release levers make it possible to raise and lower the cot without assuming the full weight of the cot and body. The loading end legs unfold and lock automatically when unloading the cot. In confined areas, the cot acts as a two wheeled stretcher when the undercarriage is folded and locked. It slides down stairs in this position with built in stair glides. The multi level feature allows the body to be moved easily from bed to cot. The cot also allows a portable stretcher to lie evenly in place. Cot is specially designed for high floor vehicles.



### FEATURES

- Side Lift Handles
- Two-Piece Restraints
- Sidearms
- Telescoping Handles

CAT NO.	DESCRIPTION
75-2430	One-man Mortuary Cot
75-2430	One-man Mortuary Cot with sidearms
75-2430	One-man Mortuary Cot with 2 wheel locks
75-2430	One-man Mortuary Cot with sidearms, 2 wheel locks

SPECIFICATIONS	
Length	77" (196 cm)
Width	21" (53 cm)
Height	Maximum 32" (82 cm) Minimum 10" (24 cm)
Weight	51 lb (24.5 kg)
Load Limit	400 lb (181 kg)
Loading Height	(24) Max 26" (66 cm) (24H) Min 24" (61 cm)
Loading Height	(24) Max 31" (79 cm) (24H) Min 27" (69 cm)

## COT COVER

Fits One-Man Cots. Reversible slip over cover secured by elastic. Includes 12 x 14" pocket.

- Machine Washable
- Available in Suede

<b>CAT NO.</b>
75-2435



## 24-H Multi Level, One-Man© MORTUARY COT

The Model 24-H includes all the great features of the Model 24 Multi-Level and is specially designed for High-Floor Vehicles.



CAT NO.	DESCRIPTION
75-2450	high loading level, One-man Mortuary Cot
75-2451	high loading level, One-man Mortuary Cot with sidearms
75-2452	high loading level, One-man Mortuary Cot with 2 wheel locks
75-2453	high loading level, One-man Mortuary Cot with sidearms, 2 wheel locks

### 27-1 Multi-Level, FIRST CALL COT

The First Call Cot blends classic design with innovative features. All four wheels swivel. The folding end section shortens the cot by 9", and the cot's head section is tapered, making tight corners less of an obstruction. Cot is maneuverable in close quarters and narrow doorways and allows easy access to the body.

The multi-level undercarriage provides flexibility in retrieval. The loading-end wheels can be locked when necessary.



CAT NO.	DESCRIPTION
75-2460	Multi-Level first call cot
75-2462	Multi-Level first call cot with sidearms

SPECIFICATIONS	
Length	78 ¾" (200 cm)
Width	24" (61 cm)
Height	Maximum 34" (86 cm) Minimum 10" (25 cm)
Weight	62 lb (28 kg)
Load Limit	400 lb (181 kg)
Loading Height	Max 25" (64 cm) Min 23" (53 cm)

**VOLUME DISCOUNTS AND CONTRACT PRICING AVAILABLE**



## FEATURES

- Swivel Wheels
- Two-Piece Restraints
- Side Lift Handles
- Sidearms



## One-Man® Roll In Style MORTUARY COT

The Model 23 Roll In Style Cot has an extra long wheel base to provide exceptional stability. Its slide-action leg lock securely locks both sets of legs simultaneously when folded. With its legs folded and locked, the cot can be used as a two-wheeled stretcher. Stair glides reduce wear on the cot and promote smooth movement down stairs. The cot is also wide enough to accommodate a portable stretcher.



CAT NO.	DESCRIPTION
75-2476	Roll in, one man mortuary cot
75-2478	Roll in, one man mortuary cot with sidearms

SPECIFICATIONS	
Length	76" (192 cm)
Width	21" (53 cm)
Height	Maximum 32" (80 cm) Minimum 10" (24 cm)
Weight	44 lb (20 kg)
Load Limit	400 lb (181 kg)
Loading Height	Max 26" (66 cm) Min 24" (62 cm)

**VOLUME DISCOUNTS AND CONTRACT PRICING AVAILABLE**





## FEATURES

- Extra Long Wheel Base for Stability
- Slide Action Leg Lock
- Can be Used as 2-Wheeled Stretcher
- Stair Glides Reduce Wear and Tear

## OPTIONAL ACCESSORIES

- Sidearms
- Side Lift Handles
- Telescoping Handles





## FABRIC and COLOR OPTIONS

Crypton® Aria	Suede
Black	Caviar
Cabernet	Burgandy
Platinum	Fathom
Blue	

## 24-MAXX FIRST CALL COVER

Specially Designed for large bodies, Mordex material has Cordura® exterior with a inner liner. Includes a 12" x 14" pocket.

- Machine Washable
- Burgundy

CAT NO.

75-2410



## 320 FIRST CALL COVER

Fits One-Man Cots. Reversible slip over cover secured by elastic. Includes 12 x 14" pocket.

- Machine Washable
- Available in Mordex or Leatherette

CAT NO.

75-2435



## 330 FIRST CALL COVER

Fits One-Man Cots, most stretchers and standard cots, full length brass zipper. Features snap fasteners that hold it in place beneath the mattress. Includes 12 x 14" pocket. Fits cots approximately 75" x 23".

- Available in Cordura® Nylon or Leatherette

<b>CAT NO.</b>
75-2436



## 321 FIRST CALL COVER

A reversible tailored slip over cover, includes sewn in lining with a 12" x 14" pocket. Fits cots approximately 76" x 23".

- Available in leatherette or Cordura® Nylon

<b>CAT NO.</b>
75-2434



## FOLDING OPERATING TABLE

Ideal for embalming, dressing and transferring. An exclusive, one-hand release easily adjusts either end of the table from 32.5" to 38.5" with the ends being independently adjustable. The table is constructed of a stainless steel top with a convex surface, tubular aluminum frame, and 6" wheels with ball bearings.

The swivel wheels lock to keep the table stationary while in use. The drain, located in the center of the foot end, quickly eliminates fluid from the table. Folds easily for storage.

### FEATURES

- Stainless Steel Top
- Locking Swivel Wheels
- Foot-End Drain with Bucket Hook
- 7 Locking Height Positions

### CAT NO.

75-2470



### SPECIFICATIONS

Length	77" (196 cm)
Width	21" (53 cm)
Height	Maximum 32" (82 cm) Minimum 10" (24 cm)
Weight	51 lb (24.5 kg)
Load Limit	400 lb (181 kg)
Loading Height	(24) Max 26" (66 cm) (24H) Min 24" (61 cm)
Loading Height	(24) Max 31" (79 cm) (24H) Min 27" (69 cm)



## COMBINATION OPERATING TABLE

The combination operating table is a multipurpose table, ideal for embalming, transferring and dressing. For added convenience, each end can be adjusted independently for individual working height and drainage.

The stainless steel top is durable and rigid, featuring a convex surface and deep side troughs for efficient drainage without the need for splash guards. Six inch wheels with locks keep the table stationary while in use.

<b>CAT NO.</b>
75-2472



FEATURES
<ul style="list-style-type: none"> <li>• Stainless Steel Top</li> <li>• Locking Swivel Wheels</li> <li>• Foot-End Drain with Bucket Hook</li> <li>• 7 Locking Height Positions</li> </ul>

SPECIFICATIONS	
Length	80" (205 cm)
Width	30" (77 cm)
Height	Maximum 38" (97 cm) Minimum 32" (82 cm)
Wheelbase	27" x 53" (69 x 136 cm)
Weight	80 lb (36 kg)
Load Limit	1000 lb (450 kg) (454 kg)





## FOLDING DRESSING TABLE

Preparation/Dressing Table unfolds quickly when you need it, stores compactly when your done. The two piece, laminated top resists scratches and stains and can be cleaned in seconds. Four 6" swivel wheels are equipped with locks.



CAT NO.	DESCRIPTION
75-2480	Woodgrain top
75-2482	Grey top



FEATURES
<ul style="list-style-type: none"> <li>• Laminated Table Top</li> <li>• Swivel Wheels with Locks</li> </ul>

SPECIFICATIONS	
Length	77" (196 cm) Folded 16" (41 cm)
Width	24 ½" (62 cm)
Height	Open/Max 34" (86 cm) Folded/Min 59" (150 cm)
Weight	68 lb (31 kg)
Load Capacity	500 lb (227 kg)

**VOLUME DISCOUNTS AND CONTRACT PRICING AVAILABLE**

## DRESSING TABLE

An exclusive, one-hand release on the table allows you to quickly adjust the table height from 32" to 38". Table rolls on 4 6" swivel wheels that lock directionally for stability.



CAT NO.	DESCRIPTION
75-2486	Woodgrain top
75-2488	Grey top



FEATURES
<ul style="list-style-type: none"> <li>• Laminated Table Top</li> <li>• Swivel Wheels with Locks</li> </ul>

SPECIFICATIONS	
Length	Open 77" (196 cm)
Width	24½" (62 cm)
Height	Open/Max 38" (97 cm)
Weight	77 lb (35 kg)
Load Capacity	500 lb (227 kg)

**DONT' SEE WHAT YOU ARE LOOKING FOR?  
GIVE US A CALL**



## CEMETERY CHURCH TRUCK

Made of strong, rectangular aluminum tubing, featuring a protective gloss-anodized finish, keeps the truck looking new and makes it easy to clean. The stable x-frame undercarriage and rubber bumpers help secure the casket. Large, eight-inch pneumatic wheels roll easily over grass or rough terrain. With four swivel wheels allowing for greater maneuverability and two wheel locks. When moved without a casket a special built-in center handle allows the truck to be pushed, pulled or carried. Includes four side handles for lifting over curbs.

The Cemetery Church Truck locks into four positions, allowing a wide range of casket sizes to be displayed with one truck. The additional length increases stability and makes an attractive appearance. Available in clear, bronze, gold, blue-grey or onyx finish.

Not compatible with drape frames or drapes.

CAT NO.

FERNO 87-HCCT



SPECIFICATIONS	
Length	61" (156 cm)
Width	18" (46 cm)
Height	25" (64 cm)
Weight	59 lb (27 kg)
Load Limit	1000 lb (454 kg)

### FEATURES

- Superior craftsmanship to maintain finish and allow for easy cleaning
- Stable x-frame to secure casket
- Six-inch wheels to roll easily over a variety of terrain
- Locks into four positions to allow for a range of casket sizes

## MODEL 87 CHURCH TRUCK

Made of strong, rectangular aluminum tubing, with a protective gloss anodized finish that keeps the truck looking new and makes it easy to clean. The stable x-frame undercarriage and rubber bumpers help to secure the casket. Six-inch rubber wheels roll easily over carpet, sills and other obstacles with quiet dignity. When moved without a casket, a special built-in center handle allows the truck to be pushed, pulled or carried. The Model 87 Church Truck locks into four positions, allowing a wide range of casket sizes to be displayed with one truck. The additional length increases stability and makes an attractive appearance. Available in bronze, gold, blue-grey, silver or onyx finish.

CAT NO.

FERNO 87

FERNO 87-HG



SPECIFICATIONS	
Length	61" (156 cm)
Width	18" (46 cm)
Height	22" (64 cm)
Weight	36 lb (16 kg)
Load Limit	1000 lb (454 kg)

### FEATURES

- Superior craftsmanship to maintain finish and allow for easy cleaning
- Stable x-frame to secure casket
- Six-inch wheels to roll easily over a variety of terrain
- Locks into four positions to allow for a range of casket sizes

## BODY BOARD SUPPORT

Elevates the body above the operating table, allowing waste to be flushed away quickly.

- Aluminum Construction with a powder coated finish to protect against corrosion

<b>CAT NO.</b>
75-2464



## BODY SCOOP

May be placed under the body without rolling or lofting. Quick release hinge separates the top and bottom for positioning under the body.

- Lightweight aluminum
- L: 65" x W: 79" x Height: Max: 17" / Min: 3"
- Load Limit: 350 lbs

<b>CAT NO.</b>
75-2462BODY



**SMALL DISSECTING TABLES**

CAT NO.	SPECIFICATIONS
90-0100	L 24" x W 17" x H 14"

**STANDARD FEATURES:**

- Fabricated of Polished Stainless Steel
- Provides a Stable Work Surface
- Tray Creased Toward Center Drain
- Drain has Hose Attachment to Route Flo

**FOLDING DISSECTING TABLE**

CAT NO.	SPECIFICATIONS
90-0110	L 23 1/2" x W 16 1/2" x H 12 1/2"

**STANDARD FEATURES:**

- Perforated Tray for Easy fluid Drainage
- Legs fold via Stainless Steel Hinges
- Safety Stop Hold Legs in Upright Position
- Sturdy design that can be placed on any counter top

**OPTIONAL ACCESSORIES:**

- Dissecting Boards
- Manufactured from high density polyethylene
- Surface and edges are chamfered, Non-Skid rubber bumpers
- White opaque surface provides excellent background

CAT NO.	SPECIFICATIONS
90-0120	23" x 16" x 3/4"

OTHER SIZES AVAILABLE, CUSTOMIZED TO YOUR SPECIFICATIONS

**PORTABLE DISSECTION CART**

Fabricated from 14 gauge 304 Stainless Steel with a No. 4 Finish. Cart Features a Sloping Tabletop for Positive, Rapid Drainage. Designed to be used as a Movable Dissecting Area, Especially Useful when used with Pedestal Mounted Autopsy Stations.

CAT NO.	SPECIFICATIONS
90-0850	Fixed Height
90-0852	Adjustable Height
Specifications:	L 48" x W 24" x H 35" - 41"

Fabricated from 1 1/2" Square, 14 gauge 304 Stainless Steel Tubing  
Top Tray is Adjustable in one inch Increments from 35" to 41".

(Fixed Height Models also Available)

Four 6" Casters, all with Brake Mechanisms

The Bottom Shelf is Fabricated of 14 gauge Stainless Steel

Compatible with most Autopsy Tables



## DISSECTING TABLE

An Economical Dissection Platform for use in Research Laboratories and Medical Schools. Table Features a Recessed Tabletop Creased toward the Drain for Positive, Rapid Drainage.

CAT NO.	SPECIFICATIONS
90-0830	Dissecting Table

### SPECIFICATIONS:

L 80" x W 30" x H 36"

### STANDARD FEATURES:

- Recessed Tabletop Creased toward the Drain for Positive, Rapid Drainage.
- All 304 Stainless Steel Construction with #4 finish
- Four 8" Swivel Lockable Casters, all with Brake Mechanisms
- Table Sockets Located on all Four Corners to Accommodate Bookstands and Leg
- Supports (Sold Separately See Accessories Listed Below)
- Removable Utility Shelf



### OPTIONAL ACCESSORIES:

- Bookstands, Stainless Steel, CAT NO. 90-0802
- Leg Support - One Piece, Stainless Steel CAT NO. 90-0803
- Leg Supports, Stainless Steel CAT NO. 90-0804
- Kick Bucket (Pails) & Stand, Stainless Steel Construction (See page 165)



**IMMERSION DISSECTING TABLE**

CAT NO.	SPECIFICATIONS
90-0810	Hand Crank Lifting Mechanism
90-0820	Manual Lifting Mechanism

**INTERNAL TANK DIMENSIONS:**

L 80" x W 27" x H 15"

**STANDARD FEATURES:**

- Two Models Available: A Hand Crank Lifting Mechanism, A Manual Lifting Mechanism
- All Stainless Steel Construction
- Inner Tray Drains Instantly and can be Removed for Cleaning Purposes
- Two Hinged Top Panels have Gaskets to Insure a Tight Seal
- Four 8" Swivel Casters, all with Brake Mechanisms
- Table Sockets Located on all Four Corners to Accommodate Bookstands and Leg Supports ( Sold Separately See Accessories Listed Below )
- Convenient Drain Valve



**STAINLESS PRODUCTS CAN BE MADE TO YOUR SPECS**



## DISSECTING TABLE

with TWO SECTION HINGED COVER

Ideal for Use in any University Cadaver Dissection Course. Fabricated from Heavy Gauge 304 Stainless Steel with a No. 4 Finish. Hinged Covers can be Securely Closed when not in use and Fastened Securely Beneath the Tabletop when Opened.

CAT NO.	DESCRIPTION
90-0800	Dissecting Table with Hinged Cover

### OVERALL DIMENSIONS:

- L 86" x W 32"
- H 37" (to top table)
- 50" (to top covered hood)



### STANDARD FEATURES:

- All Stainless Steel Construction
- Recessed Table Top with Rounded Corners for Easier Cleaning
- Four Swivel 8" Casters, all equipped with Brake Mechanism
- Table Sockets Located on all Four Corners to Accommodate Bookstands and Leg Supports (Sold Separately See Accessories Listed Below)
- The Hinged Covers Overlap and are Fitted with a Gasket to Provide a Tight Seal
- Bump latches are provided to Securely and Easily Close the Covers

## DISSECTION CART, TWO TIER, WITH ROLLERS

The Two Tier Dissecting Cart is Best Utilized in Anatomy Labs and Classroom Settings. The two levels provide storage and access to the appropriate cadaver.

CAT NO.	DESCRIPTION
90-0592-CUSTOM	Two Tier, 2.5 Gal Carboys, L 79 5/8" x W 30 1/4" x H 37"

### STANDARD FEATURES:

- All Stainless Steel Construction with #4 Finish
- Four 8" Swivel Lockable Casters, all with Brake Mechanisms
- Table Sockets Located on all Four Corners to Accommodate Bookstands and Leg
- Supports (Sold Separately See Accessories Listed Below)
- Drawer with Sidehole

### OPTIONAL ACCESSORIES:

- Bookstands, Stainless Steel. CAT NO: 90-0802
- Leg-Support- One Piece, Stainless Steel CAT NO: 90-0803
- Leg Supports, Stainless Steel CAT NO: 90-0804
- Kick Bucket (Pails) & Stand, Stainless Steel Construction
- Bump latches are provided to Securely and Easily Close the Covers





**DISSECTING TABLE with VENTILATION CHAMBER**

and TWO SECTION HINGED COVER

Removable Stainless Steel Air Distribution Baffle Creates Uniform Downdraft Airflow Around the Work Surface that Provides Proper Ventilation. Built with a 6" Diameter Exhaust Ventilation Connection at One End of Table. Center Plenum to be Located Below Work Surface Along Entire Length of Table. Supports a Table Drain Pan to Slope Under Plenum for Easy Drainage.

CAT NO.	DESCRIPTION
90-0936	Dissecting Table with Ventilation Chamber

**OVERALL DIMENSIONS:**

- L 86" x W 31 ½"
- H 37" (to top table)
- 50" (to top covered hood)

**STANDARD FEATURES:**

- All Type 304 Stainless Steel Construction
- Heliarc Welded with Exposed Welds Ground and Polished to Match Adjoining Surfaces
- Four 8" Lockable Swivel Casters, all Equipped with Brake Mechanism
- Support Sockets Located on Four Corners Accommodates Optional Bookstand or Leg Supports
- Hinged Covers Overlap and are Fitted with a Gasket to Provide a Tight Seal
- Bump Latches are Provided to Securely and Easily Close the Covers



**STAINLESS PRODUCTS CAN BE MADE TO YOUR SPECS**

## DISSECTING BOARDS

Dissecting Boards are Manufactured from High Density Polyethylene, Providing an Excellent Cutting Surface.

### STANDARD FEATURES:

- All top edges are chamfered and all bottom corners have a non-skid rubber bumper
- Custom Sizes Available
- Available with or without Bumper
- Elevated Board also available
- Color : Opaque White

CAT NO.	SIZE
90-0120	24" x 18" x 3/4"
90-0122	16" x 12" x 3/4"
90-0124	11" x 12" x 3/4"
90-0126	9" x 13" x 3/4"



## BODY BOARDS

Machined from a Solid Piece of High Density Polyethylene.

Boards raise the body above the work surface allowing for added fluid drainage  
Non-Skid rubber bumpers are placed where contact is made with the work surface

CAT NO.	DESCRIPTION
90-0140	Body Boards (Set of Three)

(21 3/4" L) x (3" W) x 1 3/4" Thickness

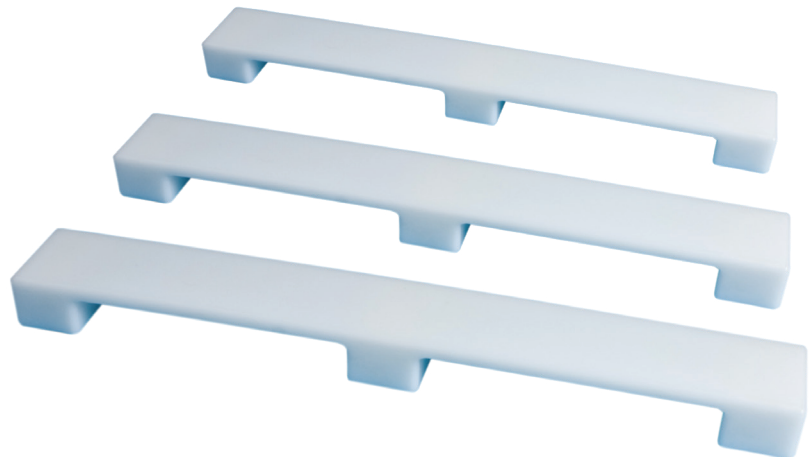

**HEADBLOCK**

Our Headblocks are molded to perfection.

Made from Stain Resistant PU Material, Aluminum, and Rubber, they clean easily and completely.

The colors give your preparation room a clean and sanitary professional look.

CAT NO.	MATERIAL	COLOR
200-200	Sani-Block	White
200-212	Aluminum	Gray
200-214	Rubber	Black

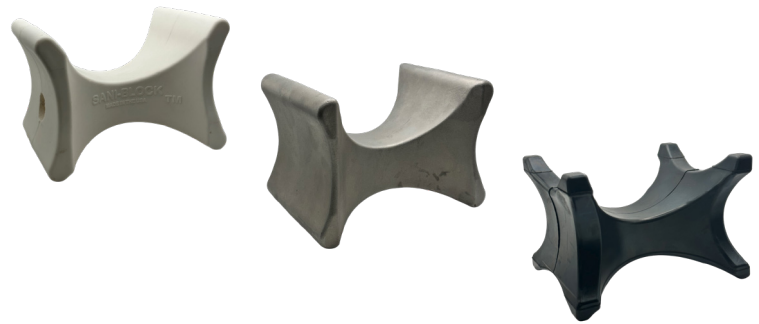
**Kick Bucket (PAILS) & Stand**

Pails are tapered for easy pouring..

"Ears" for handles are an integral part of pail, resisting breakoff, allowing for easy cleaning.

Sturdy construction.

CAT NO.	DESCRIPTION
22-2500	13 Qt. Pail, 11 5/8 x 9 1/4
22-2502	16 Qt. Pail, 11 3/4 x 10 1/8
22-2504	20 Qt. Pail, 13 3/4 x 11 13/16
22-2506	Kick Bucket Stand

\*Stand Fits Sizes 22-2500 / 22-2502

Stainless Steel Stand Supported by 4 Rubber Casters.

**One Piece Stainless Steel Leg Support**

A functional one piece removable style leg post made to fit inside the table. Provides an alternative to our two piece stainless steel leg supports.

CAT NO.
90-803



## ISCERA BAGS

Chem-Proof, TEAR RESISTANT Bags will Preserve Contents Longer

Made with 4 mil Polyethylene sheeting and strong ties. The Viscera Bag securely holds chemically treated organs and aids with leakage problems.

2 Sizes available - Color: Clear

CAT NO.	DESCRIPTION	QTY
11-830	24" x 24", 0.10 mm (4 mil)	50/Box
11-840	20" x 30", 0.10 mm (4 mil)	50/Box



## TOE TAGS

Aids in Quick Cadaver Identification. Toe Tags with Elastic Band. Available in Card stock and Polypropylene.

SIZE: 3" x 5.5"

Color: Bright White

CAT NO.	MATERIAL	QTY
11-870	Card Stock	100 /Pack
11-870PP	Plastic/Polypropylene	100 /Pack

I.D. TAG

DECEASED \_\_\_\_\_ DATE \_\_\_\_\_

PLACE OF DEATH \_\_\_\_\_

TRANSPORTED BY \_\_\_\_\_

PROPERTY TAKEN \_\_\_\_\_

PROPERTY LOCATION \_\_\_\_\_

CASE NO. \_\_\_\_\_ INVESTIGATOR \_\_\_\_\_

SIGNATURE \_\_\_\_\_

REMARKS/ADDITIONAL INFORMATION - SEE REVERSE SIDE

**UNIVERSAL CARRIER for Stainless Steel Trays**

Stainless Steel Universal Carrier is designed for use with our stainless steel trays, (Sold Separately CAT No's. 90-0650 / 90-0660 / 90-00680). Economically priced. Fabricated with a permanent slope of 1 ½". Superior performance for heavy-duty use.

**CAT NO.**

90-0540

**SPECIFICATIONS**

DESIGN LOAD	750 lbs
DIMENSIONS	L 57 ½" x W 31 ½" x H 34"

**FEATURES:**

- All 304 stainless steel construction with #4 finish
- Four Heavy Duty 8" Swivel Casters for Easy Movement with Brake Mechanism

Stainless Steel  
Cart Top

**SPECIFICATIONS**

SHIPPING WT	95 lbs
DESIGN LOAD	500 lbs
DIMENSIONS	L 80 ½" x W 32" x H 1 ½"

**CAT NO.**

90-0652



Stainless Steel  
Cart Top with Trough

**SPECIFICATIONS**

SHIPPING WT	110 lbs
DESIGN LOAD	750 lbs
DIMENSIONS	L 83 ½" x W 32" x H 1 ¾"

**CAT NO.**

90-0660



Stainless Steel  
Bariatric Tray Top

**SPECIFICATIONS**

SHIPPING WT	130 lbs
DESIGN LOAD	750 lbs
DIMENSIONS	L 84" x W 42" x H 1 ¾"

**CAT NO.**

90-0580

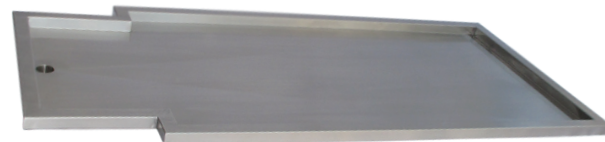

## STANDARD CARRIER

For Stainless Steel Standard Body Trays

Stainless Steel Standard Carrier is designed for use with our standard stainless steel cadaver trays, (Sold Separately CAT No's. 90-0670 / 90-0670HS). Economically priced yet it performs very well under heavy-duty use. Fabricated with a permanent slope of 1 1/2".

SPECIFICATIONS	
DESIGN LOAD	500 lbs
HEIGHT:	34"

CAT NO.
90-0572

## FEATURES:

- Fabricated from 1 1/2" square, 11 gauge, 304 stainless steel tubing
- Stainless steel has a grained finish and all welds match adjoining surfaces
- Four heavy duty 8" swivel casters for easy movement, brake mechanisms



## STANDARD BODY TRAY

All inside Corners are smoothly finished for easy cleaning; edges are rolled and welded for extra strength and easy handling.

CAT NO.	DESCRIPTION
90-0670	BODY TRAY without Handslots
90-0670HS	BODY TRAY with Handslots



SPECIFICATIONS	
DESIGN LOAD	500 lbs
DIMENSIONS	L 77 1/2" x W 23 1/8" x H 2 3/4"



**ECONOMY CARRIER CAT NO. 90-0570**

Designed for Use with Our Hi-Tech Plastic Carrier Top

Carrier is fabricated with a Permanent Slope of 1 ½", (Tray Sold Separately Cat No. 90-0620).

SPECIFICATIONS	
DESIGN LOAD	500 lbs
DIMENSIONS	L 80 ½" x W 26" x H 34"

**FEATURES:**

- Fabricated from 1 ½" Square, 11 Gauge, 304 Stainless Steel Tubing
- Top Tray Holder Fabricated from 1" Square, 11 Gauge, 304 Stainless Tubing
- Stainless Steel has a Grained Finish, All Welds Match Adjoining Surfaces
- Four Heavy Duty 8" Swivel Casters for Easy Movement All with Brake Mechanism

**OPTIONAL ACCESSORIES:**

- Designed for Use with Our Hi-Tech Plastic Carrier Top (Tray Sold Separately Cat No. 90-0620)

**OPTIONAL ACCESSORIES:**

Hi-Tech Plastic Carrier Top with X-Ray Slide Rail

Hi-Tech Plastic is Designed for Use on an Autopsy Carrier or Racking System. The Top is Formed with Ribs for Easy Drainage. X-rays May be Performed without the Removal of the Cadaver from the Autopsy Table. A Reinforced Structure on the Bottom Enables Easy Mobility by Forklift or Floor Lift.

CAT NO.	DESCRIPTION
90-0620	Hi-Tech Plastic Carrier Top (Sold Separately)

SPECIFICATIONS	
DESIGN LOAD:	500 lbs
DIMENSIONS:	L 82" x W 31 ½" x H 4"
COLOR:	Blue



## Hi-Tech Plastic Carrier Top with X-Ray Slide Rails

Shaped to Fit the Sub-Frame of Our Carrier Chassis CAT No. 90-0570 (Carrier CAT No. 90-0570 sold separately). Tray top is formed with ribs for easy drainage. X-rays may be performed without the removal of the cadaver from the autopsy table.

CAT NO.	DESCRIPTION
90-0620	Hi-Tech Plastic Top

SPECIFICATIONS	
DESIGN LOAD	500 lbs
DIMENSIONS	L 82" x W 31 1/2" x H 4"

COLOR: Blue



### FEATURES:

- Detachable Tray Top Ensures a Secure fit to Carts, no Mechanical Fastening Devices Required
- Features a Depressed Pattern Allowing Fluids to Drain Easily
- Fabricated with a Drain Hole for Easy Drainage
- X-Rays Can be taken without the Removal of the Cadaver from the Autopsy Table by Inserting the X-ray Cartridge in to the Slide Rails Found on the Underside of the Tray
- A Reinforced Structure on the Bottom Enables Easy Mobility from the Rack to the Chassis
- through the Use of a Cadaver Lift



**STAINLESS PRODUCTS CAN BE MADE TO YOUR SPECS**

**AUTOPSY CARRIER with GRID PLATES**

This Autopsy Carrier is the same quality as our Stainless Steel Universal Carrier (CAT No. 90-0540) added with our Stainless Steel Cadaver Tray (CAT No. 90-0650). Economically priced. Fabricated with a permanent slope of 1 ½". Superior performance under heavy-duty use. Four removable perforated 14 gauge stainless steel grid plates.

CAT NO.	DESCRIPTION
90-0544	Autopsy Carrier with Grid Plates



SPECIFICATIONS	
DESIGN LOAD	500 lbs
DIMENSIONS	L 80 ½" x W 32" x H 32 ½" to 34"

**FEATURES:**

- Four Heavy Duty 8" Swivel Casters for Easy Movement All with Brake Mechanism
- CART TOP TRAY: Has Full Length Creases Running Toward the Drain for Rapid, Positive Drainage. Fabricated from 14 gauge, 304 Stainless Steel with a No. 4 Finish.
- All Exposed Welds are Ground and Polished to Match Adjoining Surfaces
- GRID PLATES: Four Removable Perforated Grid Plates, made with 14 gauge 304 stainless steel
- CART FRAME: Made with 304 Stainless Steel Heavy Duty 1 ½" Square 11 Gauge Tubing. All Welding is Continuous with an approximate 1/8" Radius Bead
- All Exposed Welds are Ground and Polished to Match Adjoining Surfaces

**STAINLESS PRODUCTS CAN BE MADE TO YOUR SPECS**

## BARIATRIC AUTOPSY CARRIER

Every Facility Should Have at Least One of These on Hand.

Designed for Extra Large Cadaver Cases. Manufactured Using Optimum Design and Materials for use in the most Extreme Conditions. The Cart Top is Non-Removable. Designed to be Used in Conjunction with Our Wall Mounted Autopsy Sinks.

CAT NO.	DESCRIPTION
90-0564	Bariatric Autopsy Carrier



SPECIFICATIONS	
DESIGN LOAD	750 lbs
DIMENSIONS	L 84" x W 42" x H 34"
WIDTH NARROW PT:	32"
SHIPPING WEIGHT:	145 lbs approx.

### FEATURES:

- BARIATRIC CART TOP TRAY: Fabricated from 14 Gauge, 304 Stainless Steel with a No. 4 Finish. All Exposed Welds are Ground and Polished to Match Adjoining Surfaces
- CART FRAME: Heavy-Duty 1 ½" Square 11 gauge with 304 Stainless Steel Tubing.
- All Welding is Continuous with an Approximate 1/8" Radius Bead
- Cart has a Permanent Slope of 1 ½ inches for Rapid Draining
- Four (4) Heavy-Duty 8" Swivel Lockable Casters, All with Brake Mechanisms

**VOLUME DISCOUNTS AND CONTRACT PRICING AVAILABLE**

## C-ARM AUTOPSY CARRIER CAT NO. 90-0574

X-Ray Accessible

The X-RAY Accessible Autopsy Carrier is specifically designed for the use with portable C-ARM X-Ray machines. Frame construction allows the C-ARM to travel the full length of the carrier without obstruction. Designed for use with the Hi-Tech Plastic Carrier Top (Tray Sold Separately Cat No. 90-0620)

### FEATURES:

- Fabricated from 1 ½" square, 11 gauge, 304 stainless steel tubing Stainless steel has a grained finish and all welds match adjoining surfaces
- Four Heavy Duty 8" Swivel Casters for Easy Movement, All with Brake Mechanism
- Design Load: 500 lbs

CAT NO.

90-0574



### OPTIONAL ACCESSORIES:

Hi-Tech Plastic Carrier Top with X-Ray Slide Rail

Hi-Tech Plastic is Designed for Use on an Autopsy Carrier or Racking System. The Top is Formed with Ribs for Easy Drainage. X-rays May be Performed without the Removal of the Cadaver from the Autopsy Table. A Reinforced Structure on the Bottom Enables Easy Mobility by Forklift or Floor Lift.

CAT NO.	DESCRIPTION
90-0620	Hi-Tech Plastic Carrier Top (Sold Separately)

SPECIFICATIONS	
DESIGN LOAD:	500 lbs
DIMENSIONS:	L 82" x W 31 ½" x H 4"
COLOR:	Blue



## TWO BODY STORAGE CARRIER

DESIGNED TO MAXIMIZE SPACE, Our Two Body Storage Carrier is designed to hold two bodies with Our Hi-Tech Plastic Trays (Sold separately Cat No. 90-0620). Easily movable, with four 6" diameter rigid casters all with brake mechanism.

Fabricated with 11 gauge, 304 Stainless Steel with #4 Finish for Heavy-duty Use. All Welding is a continuous bead. Trays are easily removable when used in conjunction with each other, provides an economical and convenient means of storing cadavers. Weight Capacity is 325 lbs per Level

CAT NO.	DESCRIPTION
90-0580	Two Body Storage Carrier
90-0620	Hi-Tech Plastic Carrier Top (Sold Separately)



### OPTIONAL ACCESSORIES:

Hi-Tech Plastic Carrier Top with X-Ray Slide Rail

Hi-Tech Plastic is Designed for Use on an Autopsy Carrier or Racking System. The Top is Formed with Ribs for Easy Drainage. X-rays May be Performed without the Removal of the Cadaver from the Autopsy Table. A Reinforced Structure on the Bottom Enables Easy Mobility by Forklift or Floor Lift.

CAT NO.	DESCRIPTION
90-0620	Hi-Tech Plastic Carrier Top (Sold Separately)



SPECIFICATIONS	
DESIGN LOAD:	500 lbs
DIMENSIONS:	L 82" x W 31 1/2" x H 4"
COLOR:	Blue



## TWO BODY STORAGE CARRIER

DESIGNED TO MAXIMIZE SPACE, Our Two Body Storage Carrier is designed to hold two bodies with Our Stainless Steel Standard Body Tray (Sold separately Cat No. 90-0670). Easily movable, with four 6" diameter rigid casters all with brake mechanism.

Fabricated with 11 gauge, 304 Stainless Steel with #4 Finish for Heavy-duty Use. All Welding is a continuous bead. Trays are easily removable when used in conjunction with each other, provides an economical and convenient means of storing cadavers.

Weight Capacity is 325 lbs per Level

CAT NO.	DESCRIPTION
90-0582	Two Body Storage Carrier
90-0670	Body Tray
90-0670HS	Body Tray with Handslots (Trays Sold Separately)



### OPTIONAL ACCESSORIES:

- Stainless Steel Standard Body Tray
- All Inside Corners are Smoothly Finished for easy Cleaning. All Edges are Rolled and Welded for extra Strength and Easy Handling, Fabricated with or without Hand Slots.

CAT NO.	DESCRIPTION
90-0670	BODY TRAY
90-0670HS	BODY TRAY with HANDSLOTS

SPECIFICATIONS	
WEIGHT	40 lbs
DIMENSIONS	L 77 ½" x W 23 ⅛" x H 2 ¾"
DESIGN LOAD	500 lbs



## STRETCHER - CADAVER CHASSIS

DESIGNED for MULTIPURPOSE USE

For multipurpose use in hospitals, coroner's facilities and mortuaries. A durable stainless steel frame with four 8" swivel lockable casters that allow for easy movement. Available with Corner Bumper option (Cat No. 90-0520CB)

### FEATURES:

- Fabricated from 1 1/2" square, 11 gauge, 304 stainless steel tubing
- Stainless steel has a grained finish and all welds match adjoining surfaces
- Heavy Duty 8" Swivel lockable Casters for Easy Movement and stability
- 18 gauge Stainless Steel Top (Available with or without open corners)
- Heavy-Duty Rubber Bumper around Perimeter

SPECIFICATIONS	
DESIGN LOAD	500 lbs.
HEIGHT	34"
WIDTH	26"
LENGTH	78"

CAT NO.
90-0520
90-0520CB



**STAINLESS PRODUCTS CAN BE MADE TO YOUR SPECS**

**ELEVATED AUTOPSY CART (One Side)**  
**with STAINLESS STEEL TOP**  
**MANUFACTURED for Use in the MOST EXTREME CONDITIONS**

CAT NO.	DESCRIPTION
90-0560	One Side Elevates
90-0650	Body Tray (Sold Separately)



Designed with an adjustable end which elevates up to 6 inches via a hand crank mechanism. Cart Tops are removable and interchange with most manufacturers' tops. Manufactured for use in the most extreme conditions using optimum design and materials, Described Below:

**STANDARD FEATURES:**

- Cart Top is fabricated of 16 gauge Type 304 Stainless Steel with No. 4 finish
- All Exposed Welds are Ground to match No. 4 finish Cart Frame, material is 1 ½" square 11 gauge wall Stainless Steel Tubing. Welding is Continuous with an approximate 1/8" radius bead
- Effortless turning of crank handle raises or lowers one end of the cart top up to 6 inches
- The top is recessed and creased toward the drain hole.
- **Dimensions:** 32" wide by 80 ½" long with reduced outer corners, a 1 ¾" profile with a return flange and a 2" ledge around the entire perimeter.
- Four Heavy Duty 8" Swivel Casters for Easy Movement, All with Brake Mechanism

**OPTIONAL ACCESSORIES:**

STAINLESS STEEL CART TOP with TROUGH CAT NO. 90-0660

Stainless Steel Autopsy Cart Top is fabricated with a perimeter trough which allows fluid to flow away from the body and down the sides of the platform toward the drain. Unit is fabricated from 14 gauge, 304 stainless steel with a No. 4 finish. All exposed welds are ground and polished to match adjoining surfaces.



SPECIFICATIONS	
LENGTH	83 ½"
HEIGHT	1 ¾"
WIDTH	32"
DESIGN LOAD	750 Lbs.

**CAT NO.**

90-0660

## ELEVATED AUTOPSY CART (Both sides)

Our Elevating Autopsy Cart is designed for both ends to elevate up to 6 inches via a hand crank mechanism. Cart has a permanent 1 ½" slope. The cart tops are removable and interchange with most manufacturers' tops. Our autopsy carts are manufactured for use in the most extreme conditions, using optimum design and materials, as Described Below:

CAT NO.	DESCRIPTION
90-0566	Elevates on Both Sides
90-0650	Body Tray (Sold Separately, Pictured with Cart)
90-0660	Body Tray (Sold Separately, Shown Below)



### FEATURES:

- Cart Top is fabricated of 16 gauge Type 304 Stainless Steel with No. 4 finish
- All Exposed Welds are Ground to match No. 4 finish Cart Frame, material is 1 ½" square 11 gauge wall Stainless Steel Tubing. Welding is Continuous with an approximate 1/8" radius bead
- Effortless turning of crank handle raises or lowers one end of the cart top up to 6 inches
- The top is recessed and creased toward the drain hole.
- **Dimensions:** 32" wide by 80 ½" long with reduced outer corners, a 1 ¾" profile with a return flange and a 2" ledge around the entire perimeter.
- Four Heavy Duty 8" Swivel Casters for Easy Movement, All with Brake Mechanism

### OPTIONAL ACCESSORIES:

STAINLESS STEEL CART TOP with TROUGH  
 CAT NO. 90-0660

Stainless Steel Autopsy Cart Top is fabricated with a perimeter trough which allows fluid to flow away from the body and down the sides of the platform toward the drain. Unit is fabricated from 14 gauge, 304 stainless steel with a No. 4 finish. All exposed welds are ground and polished to match adjoining surfaces.

SPECIFICATIONS	
LENGTH:	83 ½"
HEIGHT:	1 ¾"
WIDTH:	32"
DESIGN LOAD:	750 Lbs.

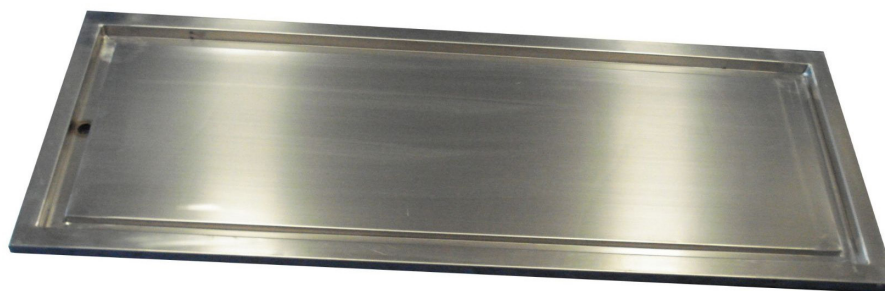

**CARRIER with ROLLERS**

Carrier with Rollers is designed as an Integral Part of the Total Rolling System for Cadaver Handling. It Accepts Standard Body Trays (Sold Separately CAT No. 90-0670, 90-0670HS) Used in the Mortuary Roller Rack System (Cat No. 90-1030 or any of the Mortuary Refrigerators). It can be Fabricated Simply as a Transfer Carrier or it can be Sloped for Drainage Purposes and can be Used as the Actual Autopsy Carrier. The Rollers Allow for Easy Loading and Unloading of Cadavers. With the Complete Total Rolling System, Minimal Manual Cadaver Handling is Necessary.

CAT NO.	DESCRIPTION
90-0590	Stainless Steel Autopsy Carriage
90-0670HS	Body Tray (Sold Separately)



SPECIFICATIONS	
CARRIER WEIGHT:	145 lbs. approx.
DESIGN LOAD:	500 lbs.
HEIGHT:	34"



Carrier can be made to adapt to any tray

**FEATURES:**

- All Heavy Gauge Stainless Steel Construction
- Heliarc Welded Seams and Joints, Polished to Match Adjoining Surfaces
- Standard Design for 23 inch Body Tray, Can also be Made to Adapt to Other Trays
- Four Swivel 8" Casters, all with Brake Mechanism

**STANDARD BODY TRAY**

All Inside Corners are Smoothly Finished for easy Cleaning. All Edges are Rolled and Welded for extra Strength and Easy Handling, Fabricated with or without Hand Slots.

CAT NO.	DESCRIPTION
90-0670	BODY TRAY
90-0670HS	BODY TRAY with HANDSLOTS



SPECIFICATIONS	
WEIGHT:	40 lbs
DIMENSIONS:	L 77 1/2" x W 23 1/8" x H 2 3/4"
DESIGN LOAD:	500 lbs





## HYDRAULIC AUTOPSY CARRIER

TRANSPORTING CADAVERS HAS NEVER BEEN EASIER

Carrier Chassis is constructed of High Impact Plastic with Twin Hydraulics. Dual end locking levers simultaneously locks all wheels from either end. Dual side mounted hydraulic foot pedal gives you quick adjustments and individual settings with the option of lowering and raising either end 29 ½" to 41 ½" above the floor for easy working from either a standing or sitting position.

CAT NO.	DESCRIPTION
90-0290H	90-0290H Hydraulic Autopsy Carrier with Tray Top

SPECIFICATIONS	
DIMENSIONS:	L 82" x W 32" x H 29 ½" to 41 ½"
WHEELBASE:	24 ½" X 51"

### FEATURES:

- Elevates from 29 ½" to 41 ½"
- Dual Side Mounted Foot Pedals for Hydraulic Elevation
- Total Caster Lock System from both ends, Four Heavy Duty 8" Swivel Casters for Easy Movement, All with Brake Mechanism



**STAINLESS PRODUCTS CAN BE MADE TO YOUR SPECS**



**HYDRAULIC AUTOPSY CARRIER**

CARRIER CAN BE MADE to ADAPT to ANY ONE of OUR TRAY TOPS

CAT NO.	DESCRIPTION
90-0540H	Hydraulic Autopsy Carrier (Tray Sold Separately)

**CARRIER FEATURES:**

- Elevates from 29 ½" to 41 ½"
- Dual Side Mounted Foot Pedals for Hydraulic Elevation
- Total Caster Lock System from both ends, Four Heavy Duty 8" Swivel Casters for Easy Movement All with Brake Mechanism

**OPTIONAL TRAYS:**

CARRIER CAN BE MADE to ADAPT to ANY ONE of OUR TRAY TOPS (Sold Separately)



**STAINLESS PRODUCTS CAN BE MADE TO YOUR SPECS**

## HYDRAULIC CARRIER FOR PLASTIC TRAY

CARRIER is DESIGNED SPECIFICALLY to FIT OUR PLASTIC TRAYS

CAT NO.	DESCRIPTION	FRAME
90-0570H	Hydraulic Carrier for Plastic Tray 90-FRAME (Tray Sold Separately)	90-FRAME

### CARRIER FEATURES:

- Elevates from 29 ½" to 41 ½"
- Dual Side Mounted Foot Pedals for Hydraulic Elevation
- Total Caster Lock System from both ends, Four Heavy Duty 8" Swivel Casters for Easy Movement, All with Brake Mechanism



### OPTIONAL ACCESSORIES:

Hi-Tech Plastic Carrier Top with X-Ray Slide Rail

Hi-Tech Plastic is Designed for Use on an Autopsy Carrier or Racking System. The Top is Formed with Ribs for Easy Drainage. X-rays May be Performed without the Removal of the Cadaver from the Autopsy Table. A Reinforced Structure on the Bottom Enables Easy Mobility by Forklift or Floor Lift.

CAT NO.	DESCRIPTION
90-0620	Hi-Tech Plastic Carrier Top

SPECIFICATIONS	
DESIGN LOAD	500 lbs
DIMENSIONS	L 82" x W 31 ½" x H 4"
COLOR	Blue



**HYDRAULIC COVERED CADAVER CARRIER**

Fabricated from strong 11 gauge steel, 1" square, steel tubing. Construction of subassemblies are welded together. Stainless Steel

CAT NO.	DESCRIPTION
90-0600H	Hydraulic Cadaver Carrier
90-0600-C	Replacement Cover

**FEATURES:**

- Heavy gauge Stainless Steel Frame and Cadaver Tray Sturdy, Lightweight Aluminum Top Frame to Conceal Cadaver - Easily Removable
- Custom fabricated cover made of black out material Elevates from 24 ½" to 39" Foot activated twin pedestal for hydraulic elevation
- Total Caster Lock System from both ends, Four Heavy Duty 8" Swivel Casters for Easy Movement All with Brake Mechanism
- Size: L 82" x W 28" x H 24 ½" to 39" (without canopy)

**OPTIONAL ACCESSORIES:**

Cart to Sink Locking Mechanism

BARIATRIC COVERED CADAVER CARRIER

COVERED CADAVER CARRIER with rollers available

**CARRIER COVER**

REUSABLE COVER FITS EASILY & EFFICIENTLY OVER THE CARRIER

**FEATURES:**

- Black-Out, Cotton made Oxford Sturdy Fabric.
- The Reusable Cover is Extremely User Friendly, Fits easily and efficiently over the Carrier.

SPECIFICATIONS	
DIMENSIONS:	L 83" x W 29" x H 24"
COLOR:	Dark Blue
WEIGHT:	6 lbs



## COVERED CADAVER CARRIER

DISCREET TRANSPORT of CADAVERS CAT NO. 90-0600

Allows for the Discreet, Concealed Removal and Transport of Cadavers, gives the Illusion of an empty gurney while privately concealing the cadaver beneath a fabricated top cover (CAT No. 90-0600C, Sold separately). Unit features stainless steel construction and adjustable elevation via a hand crank mechanism.

### FEATURES:

- Heavy gauge Stainless Steel Frame and Cadaver Tray
- Sturdy, Lightweight Aluminum Top Frame to Conceal Cadaver - Easily Removable
- Custom fabricated Cover made of Black out Material (CAT No. 90-0600C, Sold separately)
- Hand Crank Mechanism Elevates Cadaver Tray to 38 ½"
- Four Heavy Duty 8" Swivel Casters for Easy Movement All with Brake Mechanism
- Size: L 82" x W 28" x H 26" to 38 ½"

### OPTIONAL ACCESSORIES:

- One Location Total Wheel Lock
- Level Controlled Directional Caster for ease in Steering



<b>CAT NO.</b>
90-0600

## CARRIER COVER

RESUABLE COVER FITS EASILY & EFFICIENTLY OVER THE CARRIER

### FEATURES:

- Black-Out, Cotton made Oxford Sturdy Fabric.
- The Reusable Cover is Extremely User Friendly, Fits easily and efficiently over the Carrier.

CAT NO.	DESCRIPTION
90-0600-C	Black-Out Cover

SPECIFICATIONS	
DIMENSIONS:	L 83" x W 29" x H 24"
COLOR:	Dark Blue
WEIGHT:	6 lbs



**JANAZAH BODY CARRIER**

The Janazah Body Carrier is expertly designed to provide a dignified and respectful means of transporting the deceased. Built with precision and care, this carrier features a robust and durable construction to ensure safe and secure handling. The carrier is equipped with reinforced handles and a sturdy frame, allowing for smooth and easy maneuverability in various settings.

SPECIFICATIONS	
SHIPPING WT	80 lbs
DESIGN LOAD	300 lbs
DIMENSIONS	L 78.4" x W 28.2" x H 22.4"

CAT NO.
90-0786

**OPTIONAL ACCESSORIES:**

- All 304 stainless steel construction with #4 finish
- Constructed with high tensile aluminum, which keeps the frame light weight
- Four legs with rubber caps for stability and better grip
- Ergonomically designed, telescopic handles, making it easy to store, provide a secure grip, and facilitating safe and controlled handling during transport

**STAINLESS PRODUCTS CAN BE MADE TO YOUR SPECS**  
**VOLUME DISCOUNTS AND CONTRACT PRICING AVAILABLE**



## NECROPSY DISSECTING CART, ELEVATING (BOTH SIDES)

CAT NO.	SIZE
90-0754	Width 24" x Length 48" x Height 30" to 40"



### FEATURES:

- All stainless steel construction
- All 304 stainless steel with #4 finish
- All welds are Heliarc seams and joints, ground and polished to match adjoining surfaces
- All welds are rounded and polished on all inside and outside corners for easy cleaning
- Recessed Tabletop Creased toward the Drain for Positive, Rapid Drainage
- Four 6" Swivel Lockable Casters, all with Brake Mechanisms
- Table Sockets Located on all Four Corners to Accommodate Bookstands and Leg Supports (Sold Separately, See Accessories Listed Below)

### OPTIONAL ACCESSORIES:

- Bookstands, Stainless Steel, CAT NO. 90-0802
- Leg Support - One Piece, Stainless Steel CAT NO. 90-0803
- Leg Supports, Stainless Steel CAT NO. 90-0804
- Kick Bucket (Pails) & Stand, Stainless Steel Construction (See page 175) 165
- Body support solid or perforated 4 pieces 8 inches wide



## HI-TECH PLASTIC CARRIER TOP with X-RAY SLIDE RAIL

Our Hi-Tech Plastic Operating Platform is Formed with Ribs for Easy Drainage; X-Rays can be Taken Without the Removal of the Cadaver from the Platform Top.

CAT NO.	DESCRIPTION
90-0620	CARRIER CHASSIS TOP
DIMENSIONS:	L 82" x W 31 ½" x H 4"
COLOR:	Blue
WEIGHT:	40 lbs
DESIGN LOAD:	500 lbs

### STANDARD FEATURES:

- The platform top is formed with ribs for easy drainage
- X-Rays can be taken without the removal of the cadaver from the platform top
- Detachable Top Ensures a Secure Fit With no Mechanical Fastening Devices Required
- Fabricated with a drain hole for easy drainage
- A reinforced structure on the bottom enables easy mobility from the rack to chassis through use of a cadaver lift



**VOLUME DISCOUNTS AND CONTRACT PRICING AVAILABLE**

## STAINLESS STEEL SLOPED CART TOP

Our Stainless Steel Sloped Cart Top Features a Depressed Pattern Allowing Fluids to Drain Easily. They Also Feature Sloped Sides for Easy Body Placement and Removal. Fabricated with 14 gauge, 304 Stainless Steel with #4 Finish.

CAT NO.	DESCRIPTION
90-0652	Stainless Steel Sloped Cart Top
DIMENSIONS:	L 80 ½" x W 32" x H 1 ½"
SHIPPING WT:	95 lbs
DESIGN LOAD:	500 lbs



## STAINLESS STEEL CART TOP

Our Stainless Steel Autopsy Platform Features a Depressed Pattern Allowing Fluids to Drain Easily. Fabricated with 14 gauge, 304 Stainless Steel with No. 4 Finish.

CAT NO.	DESCRIPTION
90-0650	Stainless Steel Cart Top
DIMENSIONS:	L 80 ½" x W 32" x H 1 ½"
SHIPPING WT:	95 lbs
DESIGN LOAD:	500 lbs

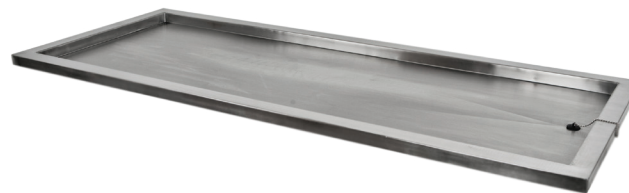

### STANDARD FEATURES:

- Detachable Top Ensures a Secure Fit to Carts, no Mechanical Fastening Devices Required
- Features a Depressed Pattern Allowing Fluids to Drain Easily
- Sloped Sides for Easy Body Placement and Removal
- Fabricated with a Drain Hole for Easy Drainage, Drain Plug Which is Fastened to the Platform to Prevent Fluid Loss in Transport or While Racking
- A Reinforced Structure on the Bottom Enables Easy Mobility From the Rack to the Chassis Through the Use of a Cadaver Lift

## STAINLESS STEEL CART TOP with TROUGH

Our Stainless Steel Autopsy Top is fabricated with a Perimeter Trough which allows Fluid to Flow Away and Down the Sides of the Platform toward the Drain. Fabricated from 14 gauge, 304 Stainless Steel with a No. 4 Finish.

CAT NO.	DESCRIPTION
90-0660	CART TOP With TROUGH
DIMENSIONS	L 83 ½" x W 32" x H 1 ¾"
SHIPPING WT	110 lbs
DESIGN LOAD	750 lbs
DESIGN LOAD	500 lbs



### STANDARD FEATURES:

- Allows Fluid to Flow Away from the Body and Down the Sides of the Platform Toward the Drain
- Fabricated from 14 Gauge, 304 Stainless Steel with a No.4 Finish. All Exposed Welds are Ground and Polished to Match Adjoining Surfaces
- Fabricated With a Drain Hole for Easy Drainage, Drain Plug Which is Fastened to the Platform to Prevent Fluid Loss in Transport or While Racking
- A Reinforced Structure on the Bottom Enables Easy Mobility from Rack to Chassis Through use of a Cadaver Lift

**VOLUME DISCOUNTS AND CONTRACT PRICING AVAILABLE**

## STANDARD BODY TRAY

Our Standard Body Tray is a Smoothly Finished 18 Gauge Stainless Steel Body Tray. Designed for use with Mortuary Refrigerators, Racks, Dissecting Tables and Carriers.

CAT NO.	DESCRIPTION
90-0670	STANDARD BODY TRAY
90-0670HS	STANDARD BODY TRAY with HANDSLOTS
DIMENSIONS	L 77 ½" x W 23 ½" x H 2 ¾"
SHIPPING WT	40 lbs
DESIGN LOAD	500 lbs



### STANDARD FEATURES:

- All Inside Corners are Smoothly Finished for easy Cleaning
- All Edges are Rolled and Welded for extra Strength and Easy Handling

### AVAILABLE TRAY OPTIONS:

- Fabricated with or without a drain hole
- Wider/Longer Body trays also available

**STAINLESS PRODUCTS CAN BE MADE TO YOUR SPECS**

## BARIATRIC STAINLESS STEEL TRAY TOP

Every Facility should have at Least One of these on Hand

Designed for Extra Large Cadaver Cases. Fabricated with a Narrow Front so it can be used with many Current Autopsy Stations. Heavy Gauge Stainless Steel Handles the Extra Weight Capacity Needed.

CAT NO.	DESCRIPTION
90-0680	BARIATRIC STAINLESS STEEL TRAY TOP
DIMENSIONS	L 84" x W 42" x H 1 ¾"
SHIPPING WT	135 lbs
DESIGN LOAD	750 lbs
DESIGN LOAD	500 lbs

### STANDARD FEATURES:

- Fabricated with 14 gauge, Reinforced 304 Stainless Steel with a No. 4 Finish
- All Inside Corners are Smoothly Finished for Easy Cleaning
- Tray has Creases Running Toward the Drain for Positive Rapid Drainage
- Fabricated with a Drain hole for Easy Drainage
- All Edges are Rolled and Welded for Extra Strength and Easy Handling
- OPTIONAL ACCESSORIES:
- DRAIN PLUG: You may Request a Drain Plug with Attaching Chain which is Fastened to the Platform to Prevent Fluid Loss in Transport or While Racking

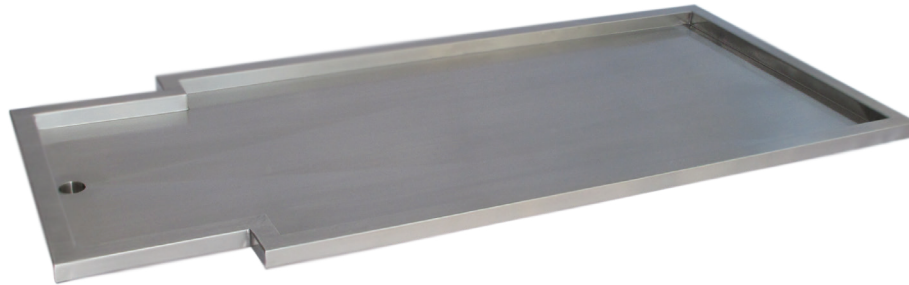

## Hi-Tech PLASTIC CARRIER TOP with X-Ray SLIDE RAIL

Formed with Ribs for Easy Drainage; X-Rays can be Taken Without the Removal of the Cadaver

DIMENSION	L 82" x W 31 ½" x H 4"
COLOR	Blue
DESIGN LOAD	500 lbs
CAT No.	90-0620



## STAINLESS STEEL CART TOP

Features a Depressed Pattern Allowing Fluids to Drain Easily and Sloped Edges for Easy Body Placement and Removal. Fabricated from 14 gauge, 304 Stainless Steel with a No. 4 Finish.

DIMENSION :	L 80 ½" x W 32" x H 1 ½"
DESIGN LOAD	500 lbs
CAT No.	90-0652



## STAINLESS STEEL CART TOP

Features a Depressed Pattern Allowing Fluids to Drain Easily. Fabricated from 14 gauge, 304 Stainless Steel with a No. 4 Finish

DIMENSION :	L 80 ½" x W 32" x H 1 ½"
DESIGN LOAD	500 lbs
CAT No.	90-0650



## STAINLESS STEEL CART TOP with TROUGH

Our Stainless Steel Autopsy Top is Fabricated with a Perimeter Trough which Allows Fluid to Flow Away and Down the Sides of the Platform Toward the Drain. Fabricated from 14 gauge, 304 Stainless Steel with a No. 4 Finish

DIMENSION :	L 83 ½" x W 32" x H 1 ¾"
DESIGN LOAD	750 lbs
CAT No.	90-0660



## STANDARD BODY TRAY

A Smoothly Finished 18 gauge Stainless Steel Body Tray. Designed for use With Mortuary Refrigerators, Racks, Dissecting Tables and Carriers.

DIMENSION	L 77 ½" x W 23 ⅛" x H 2 ¾"
DESIGN LOAD	500 lbs
CAT No.	90-0670
CAT No.	90-0670HS



## BARIATRIC STAINLESS STEEL TRAY TOP

Designed for X-Large Cadaver Cases. Fabricated With a Narrow Front so it can be Used With Many Current Autopsy Stations. Heavy Gauge Stainless Steel Handles the Extra Weight Capacity Needed.

DIMENSION	L 84" x W 42" x H 1 ¾"
DESIGN LOAD	750 lbs
CAT No.	90-0680

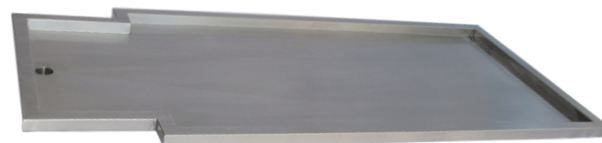





### EMBALMING WATER CONTROL CELL

CAT NO.	SIZE
90-0704	Width 17" x Length 15" 14 gauge stainless steel base plate.

Our Embalming Water Control Cell is a great way to configure your existing basic countertop into a full functioning working embalming station. The cell comes preassembled complete with plumbing lines and the following features:

#### **Elevated Stretch Spout**

The spout is designed to swivel and will easily fit and fill any embalming machine.

#### **Rinsing Hose**

The flexible rinsing hose connects quickly to the cone shaped attachment that generates a liberal water supply.

#### **Hot & Cold Water**

Equipped with a hot and cold water valve.

#### **Hydro-Aspirator Assembly**

The hydro-aspirator prevents backflow and any contamination into the water supply. The aspirator assembly also has its own water supply spout that controls the volume of water.

#### **Installation**

The cell is pre-assembled and pre-plumbed for quick installation. Place the cell into a cutout on your countertop and connect the plumbing lines. Requires minimum of 18" deep counter top.

## PORTABLE DISSECTION CART

CAT NO.	DESCRIPTION
90-0850	Fixed Height
90-0852	Adjustable Height

The DISSECTING CART is fabricated from 14 gauge 304 stainless steel with a No. 4 finish. This unit features a sloping tabletop for positive, rapid drainage into a sink or optional drain pail attachment. Designed to be used as a movable dissecting area and is especially useful when used with pedestal mounted autopsy stations. Compatible with most autopsy tables.

### FEATURES:

- Fabricated from 1 1/2" Square, 11 gauge 304 Stainless Steel Tubing
- Top Tray is Adjustable in One Inch Increments from 35" to 41". Fixed Height Models also Available
- 6"/8" Casters, all with Brake Mechanisms
- The Bottom Shelf is Fabricated of 14 gauge Stainless Steel

SPECIFICATIONS	
LENGTH	48"
HEIGHT	36"
WIDTH	24"



## PEDESTAL AUTOPSY TABLE

CAT NO.	SIZE
90-0710	Width 32" x Length 104" x Height 36"

### FEATURES:

- All stainless steel construction
- All 304 stainless steel with #4 finish. Table top, sink and grid plates are 14 gauge. Pedestal is 18 gauge
- All seams and joints are Heliarc welding , ground and polished to match adjoining surfaces
- All welds are rounded and polished on all inside and outside corners for easy cleaning
- Hydro-Aspirator has a cold water control valve as well as a reverse flow valve
- Body support solid or perforated, 4 pieces, 8 inches wide
- GFCI Two (2) duplex outlet with waterproof cover
- Spray Hose Assembly with cold water control valve nozzle and 10 ft. of pressure flexible hose
- Mixing faucet with gooseneck spout and wrist blade handles with vacuum breaker
- Heavy-duty 1/2 hp commercial disposal with switch and solenoid
- Large single compartment sink basin, 18" x 12" x 10" deep
- Rapid and positive drainage
- Removable Access Panel
- Plumbing and Electrical lines factory installed. Single point connection at customer location  
May Require a trade professional at customers location



**STAINLESS PRODUCTS CAN BE MADE TO YOUR SPECS**

## PEDESTAL AUTOPSY TABLE

### OPTIONAL FEATURES:

- Post mortem scale with scale pole and bracket
- Down draft ventilation assembly double-cone style
- Table rinse with cold water control valve and vacuum breaker
- Commercial Heavy duty Disposer 3/4 hp, 1 hp or 2 hp
- Single lever hot cold fixture
- Gas / air cocks
- Stainless steel full grid body supports are removable
- Over-the-body dissecting tray
- Headrest
- Emergency eye wash
- Dissecting tray sits on top

CAT NO.

90-0710

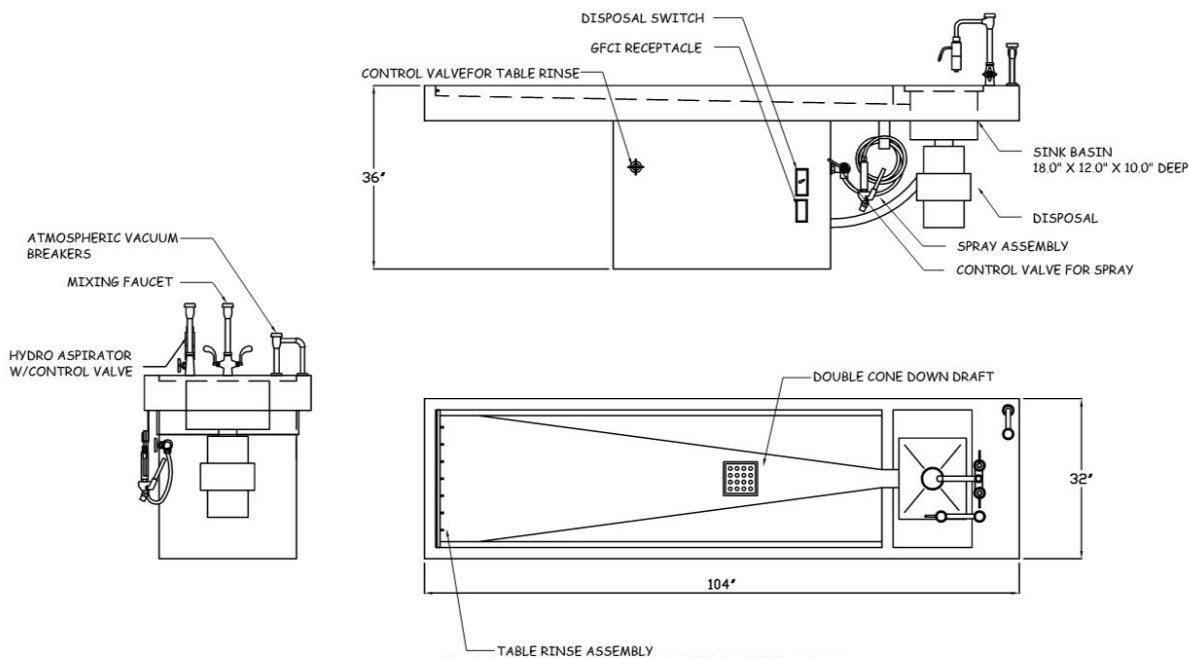

## ELEVATING PEDESTAL AUTOPSY TABLE

CAT NO.	SIZE
90-0720	Width 32" x Length 104" x Height 32" - 39"

### FEATURES:

- All stainless steel construction
- All 304 stainless steel with #4 finish. Table top, sink and grid plates are 14 gauge. Pedestal are 18 gauge
- All welds are Heliarc seams and joints, ground and polished to match adjoining surfaces
- All welds are rounded and polished on all inside and outside corners for easy cleaning
- Adjustable elevating actuators with touch control buttons
- Hydro-Aspirator with cold water control valve with reverse flow valve
- Body support solid or perforated 4 pieces 8 inches wide
- GFCI Two (2) duplex outlet with waterproof cover
- Spray Hose Assembly with cold water control valve nozzle and 10 ft. of pressure flexible hose
- Mixing faucet with gooseneck spout and wrist blade handles with vacuum breaker
- Heavy-duty 1/2 hp commercial disposal with switch and solenoid
- Large single compartment sink basin, 18" x 12" x 10" deep
- Rapid and positive drainage
- Removable Access Panel
- Plumbing and Electrical lines factory installed. Single point connection at customer location. May Require a trade professional at customers location

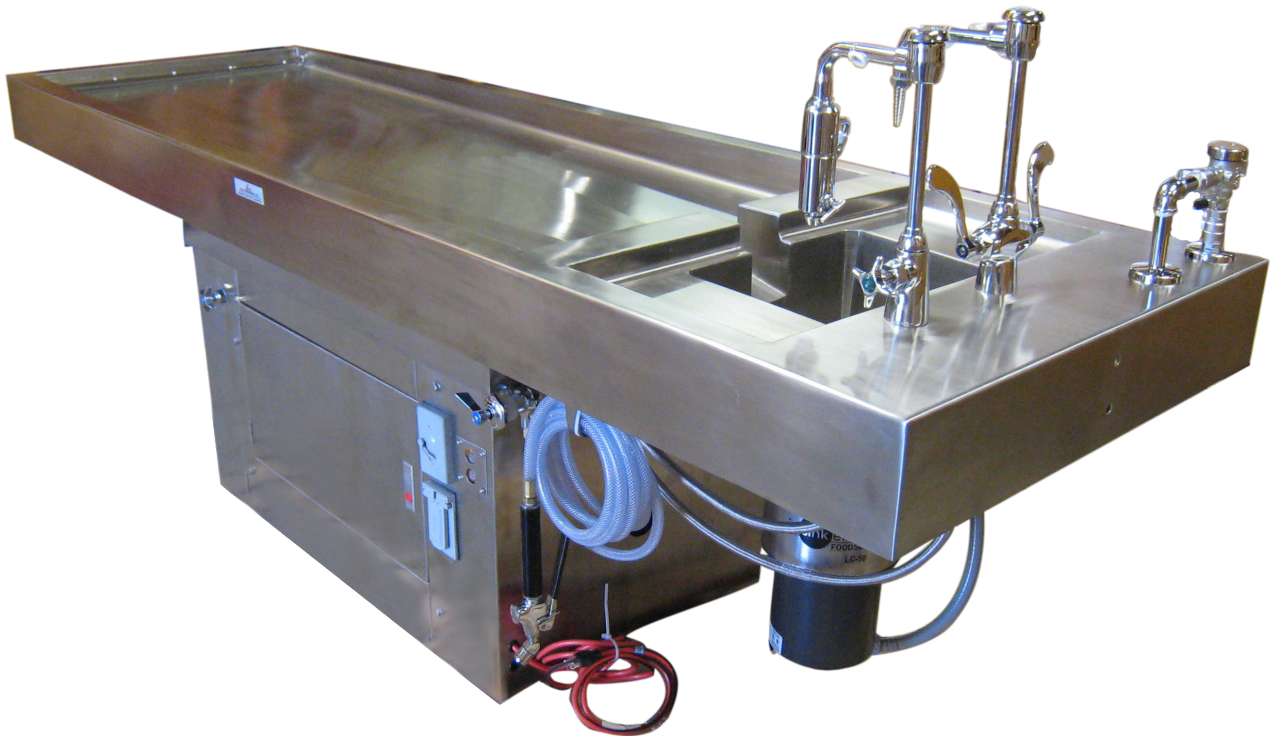

## ELEVATING PEDESTAL AUTOPSY TABLE

### OPTIONAL FEATURES:

- Post mortem scale with scale pole and bracket
- Down draft ventilation assembly double-cone style
- Table rinse with cold water control valve and vacuum breaker
- Commercial Heavy duty Disposer 3/4 hp, 1 hp or 2 hp
- Single lever hot cold fixture
- Gas / air cocks
- Stainless steel full grid body supports removable
- Over-the-body dissecting tray
- Headrest
- Emergency eye wash
- Dissecting tray sits on top

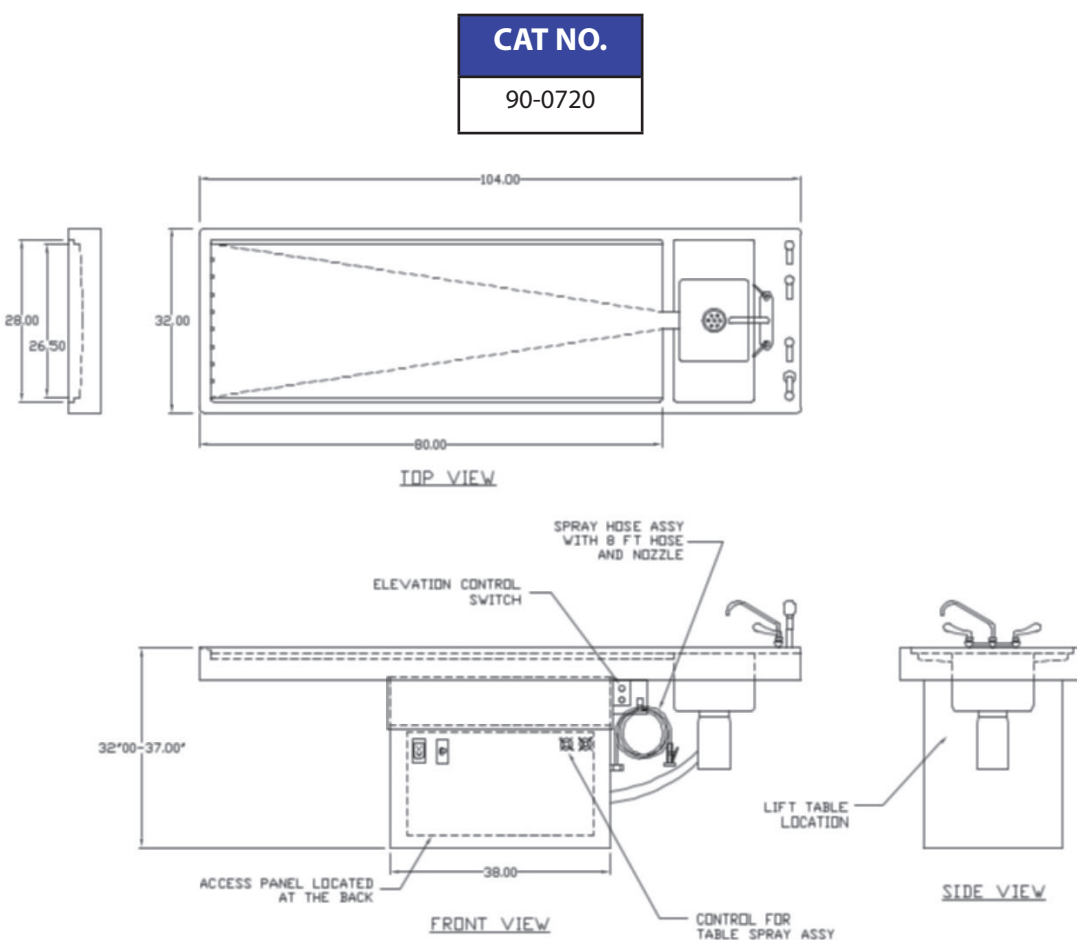



**COMPACT NECROPSY / AUTOPSY TABLE**

CAT NO.	SIZE
90-0750	Width 30" x Length 60" x Height 36"

**FEATURES:**

- All stainless steel construction
- All 304 stainless steel with #4 finish. Table top, sink and grid plates are 14 gauge. Pedestal are 18 gauge
- All welds are Heliarc seams and joints, ground and polished to match adjoining surfaces
- All welds are rounded and polished on all inside and outside corners for easy cleaning
- Hydro-Aspirator with cold water control valve with reverse flow valve
- Body support solid or perforated 4 pieces 8 inches wide
- GFCI Two (2) duplex outlet with waterproof cover
- Spray Hose Assembly with cold water control valve nozzle and 10 ft. of pressure flexible hose
- Mixing faucet with gooseneck spout and wrist blade handles with vacuum breaker
- Heavy-duty 1/2 hp commercial disposal with switch and solenoid
- Large single compartment sink basin
- Rapid and positive drainage
- Removable Access Panel
- Plumbing and Electrical lines factory installed. Single point connection at customer location May Require a trade professional at customers location

**OPTIONAL FEATURES:**

- Post mortem scale with scale pole and bracket
- Down draft ventilation assembly double-cone style
- Table rinse with cold water control valve and vacuum breaker
- Commercial Heavy duty Disposer 3/4 hp, 1 hp or 2 hp
- Single lever hot cold fixture
- Stainless steel full grid body supports removable
- Over-the-body dissecting tray
- Headrest



## L SHAPED AUTOPSY TABLE

CAT NO.	SIZE
90-0700	Autopsy Area Width 30" x Length 102" x Height 36" Dissecting Area Width 30" x Length 60" x Height 36"

### FEATURES:

- All stainless steel construction
- All 304 stainless steel with #4 finish. Table top, sink and grid plates are 14 gauge. Pedestal are 18 gauge
- All welds are Heliarc seams and joints, ground and polished to match adjoining surfaces
- All welds are rounded and polished on all inside and outside corners for easy cleaning
- "L" shaped table configuration. Large utility pedestal with smaller storage support section and pedestal
- Hydro-Aspirator with cold water control valve with reverse flow valve
- Body support solid or perforated 4 pieces 8 inches wide
- GFCI Two (2) duplex outlet with waterproof cover
- Spray Hose Assembly with cold water control valve nozzle and 10 ft. of pressure flexible hose
- Mixing faucet with gooseneck spout and wrist blade handles with vacuum breaker
- Heavy-duty 1/2 hp commercial disposal with switch and solenoid
- Large single compartment sink basin
- Rapid and positive drainage
- Removable Access Panel

### OPTIONAL FEATURES:

- Post mortem scale with scale pole and bracket
- Down draft ventilation assembly double-cone style
- Table rinse with cold water control valve and vacuum breaker
- Commercial Heavy duty Disposer 3/4 hp, 1 hp or 2 hp
- Single lever hot cold fixture
- Gas / air cocks
- Stainless steel full grid body supports removable
- Over-the-body dissecting tray
- Headrest
- Emergency eye wash
- Dissecting tray sits on top



**ROTATING & ELEVATING AUTOPSY TABLE**

CAT NO.	SIZE
90-0705	Width 33" x Length 102" x Height 32" to 38"

**FEATURES:**

- All 304 stainless steel with #4 finish. Table top, sink and grid plates are 14 gauge.
- All welds are Heliarc seams and joints, ground and polished to match adjoining surfaces
- All welds are rounded and polished on all inside and outside corners for easy cleaning
- Adjustable elevating actuators with touch control buttons
- Hydro-Aspirator with cold water control valve with reverse flow valve
- Body support solid or perforated 4 pieces 8 inches wide
- Rotates manually with a lock handle in either direction
- GFCI Two (2) duplex outlet with waterproof cover
- Spray Hose Assembly with cold water control valve nozzle and 10 ft. of pressure flexible hose
- Mixing faucet with gooseneck spout and wrist blade handles with vacuum breaker
- Rapid and positive drainage
- Removable Access Panel
- Plumbing and Electrical lines factory installed. Single point connection at customer location.  
May Require a trade professional at customers location

**OPTIONS FEATURES:**

- Post mortem scale with scale pole and bracket
- Down draft ventilation assembly double-cone style
- Table rinse with cold water control valve and vacuum breaker
- Large single compartment sink basin, 18" x 12" x 10" deep
- Commercial Heavy duty Disposer 3/4 hp, 1 hp or 2 hp
- Single lever hot cold fixture
- Gas / air cocks, vacuum valves
- Stainless steel full grid body supports removable
- Over-the-body dissecting tray
- Headrest
- Dissecting tray sits on top



## UNIVERSAL AUTOPSY TABLE

An economical and practical table which provides all the necessary features to perform routine autopsy or dissection procedures. It is mounted on four stainless steel legs with adjustable feet.

CAT NO.	SIZE
90-0730	Width 33" x Length 102" x Height 34"

(Adjustable Feet)

### FEATURES:

- All 304 stainless steel with #4 finish. Table top, sink and grid plates are 14 gauge. Pedestal are 18 gauge
- All welds are Heliarc seams and joints, ground and polished to match adjoining surfaces
- All welds are rounded and polished on all inside and outside corners for easy cleaning
- Hydro-Aspirator with cold water control valve with reverse flow valve
- GFCI Two (2) duplex outlet with waterproof cover
- Spray Hose Assembly with cold water control valve nozzle and 10 ft. of pressure flexible hose
- Mixing faucet with gooseneck spout and wrist blade handles with vacuum breaker
- Large single compartment sink basin
- Rapid and positive drainage
- Removable Access Panel
- Plumbing and Electrical lines factory installed. Single point connection at customer location. May Require a trade professional at customers location

### OPTIONS FEATURES:

- Table rinse with cold water control valve and vacuum breaker
- Commercial Heavy duty Disposer 3/4 hp, 1 hp or 2 hp
- Stainless steel full grid body supports removable
- Over-the-body dissecting tray
- Headrest
- Dissecting tray sits on top

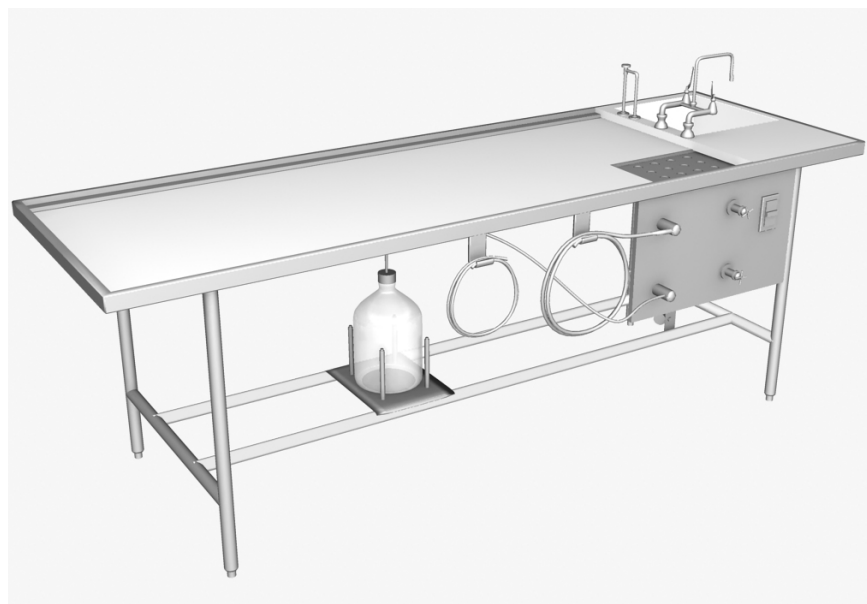

**VOLUME DISCOUNTS AND CONTRACT PRICING AVAILABLE**

## FACTORY INSTALLED PLUMBING & ELECTRICAL LINES

- Plumbing & Electrical Lines are Factory Installed & Tested before Leaving our Manufacturing Facility. Single Point Connection at Customer Location. Installation Requires a Trade Professional
- We use only High Quality Copper Lines and Fittings with all Joints Soldered, Actual Size of Lines is Dependent on Amount of Water Flow required for each Station
- Plumbing and Electrical Hook-Up is Designed to be as Simple as Possible. In Most Cases, there is only One Connection for the Drain, Hot and Cold Water, and Electrical
- Water tight Electrical Boxes and Conduits are used on our Equipment, GFCI Protected Electrical Outlet (Ground Fault Circuit Interrupter)



**STAINLESS PRODUCTS CAN BE MADE TO YOUR SPECS**



## EMBALMING STATION

SPECIFICATIONS	
Height Bottom to Top Deck:	42"
Overall Height with Faucet:	66"
Depth (Front to Back):	36"
Width (Left to Right):	32"
Shelf Depth:	16"
Sink Size ID:	(LxWxD) 29" x 18 1/2" x 10"
Electrical:	110 VAC
Material:	304 Stainless Steel
Shipping Weight:	Approx. 350 lbs

**CAT NO.**

90-0420

## UNITS CAN BE CUSTOMIZED TO MEET YOUR SPECIFICATIONS

SPECIFICATIONS	
Height Bottom to Top Deck:	42"
Overall Height with Faucet:	66"
Depth (Front to Back):	37 3/4"
Width (Left to Right):	32"
Shelf Depth:	16"
Sink Size ID:	(LxWxD) 19 5/8" x 22 1/2" x 11 3/4"
Electrical:	110 VAC
Material:	304 Stainless Steel
Shipping Weight:	Approx. 325 lbs

**CAT NO.**

90-0422



## FEATURES:

- Plumbing & Electrical Lines are Factory Installed & Tested before Leaving our Manufacturing Facility. Single Point Connection at Customer Location. Installation Requires a Trade Professional
- MATERIAL: 304 Stainless Steel Construction
- All water flows goes through a vacuum breaker
- Large Sink Basin (Economy Embalming Station Has a Smaller Sink Basin)
- Hot/Cold Water Mixing Faucet Mounted on Top Deck
- Deluxe Hydro-Aspirator with Reverse Flow
- Spray Hose Assembly with Spray Nozzle and 10 Feet of Flexible Hose
- Single Point Connection for Water and Electric
- Large Access Panels on Both Sides
- Waterproof GFCI Protected Electrical Outlet (Ground Fault Circuit Interrupter) on Both Sides

## OPTIONAL EQUIPMENT:

- Hot & Cold Water Mixing Faucet Installed on Face
- Exhaust vents
- Eye Wash Assembly
- Waste Disposal
- Perimeter Rinse Assembly
- Sink Basin Fitted Cover to prevent splash and Aerosols Containment



## EMBALMING SINK

AVAILABLE IN LEFT, RIGHT or CENTER POSITION

### FEATURES:

- Plumbing & Electrical Lines are Factory Installed & Tested before Leaving our Manufacturing Facility. Single Point Connection at Customer Location. Installation Requires a Trade Professional
- All Stainless Steel Construction
- All welds are Heliarc, all visible seams and joints are ground and polished to a smooth finish
- Large Sink Basin Long 12" x Wide 12" x Deep 9"
- **Plumbing:** Hot and Cold faucet with wrist blade handles, all external plumbing fixtures are brass with heavy chrome -plating finish
- **Ventilation:** Air ventilation chambers are supplied with quick disconnect
- Instrument drawer provided
- Spray assembly with 10' pressure hose with cold water control valve
- Vacuum deluxe hydro aspirator with reverse flow
- Two (2) perforated stainless steel removable grids
- Rinse assemblies located under the perforated dissection grids
- Heavy Duty Commercial grade disposal 1/2 hp unit (upgrade available)
- Disposer switch with solenoid
- **Receptacles:** 2 Waterproof Duplex GFCI Protected Electrical Outlet (Ground Fault Circuit Interrupter)
- Florescent Light Fixture
- All drains slope toward large drain for quick and positive drainage
- All water fixture lines go through vacuum breakers in addition to a backflow device

CAT NO.	DESCRIPTION
90-0362	Left Hand Station Shown Length: 84" Long (Available in Left, Right, and Center)



## EMBALMING SINK CAT NO. 90-0380

### FEATURES:

- Vent System
- Formalin Valve and Outlet
- Distilled Water and Outlet
- Formalin Pump Switch
- GFCI Electrical Outlet
- Air Cock
- Emergency Eye Wash Station
- Gooseneck Faucet with Wrist Blade Handles
- Spray Hose
- 12" x 12" x 9" Deep Wash Basin
- Utility Drawer (Lock Optional)
- Ground Fault Circuit Interrupt Outlet
- Disposer Switch
- 1 1/2" Waste Line
- Disposer, 1/2 hp 115 VAC, Single Phase, 60 Hz
- Full Sink Perimeter Rinse
- Stainless Steel Legs (If Required)
- Sink Perimeter Rinse Valve
- Hydro-Aspirator with Control Valve and Hose



<b>CAT NO.</b>
90-0380

### MATERIAL SCHEDULE:

- Specimen Shelf: 16 Gauge No. 304 Stainless Steel - No. 4 Satin Finish
- Backsplash: 16 Gauge No. 304 Stainless Steel - No. 4 Satin Finish
- Drainboards: 14 Gauge No. 304 Stainless Steel - No. 4 Satin Finish
- Sink: 14 Gauge No. 304 Stainless Steel - No. 4 Satin Finish
- Perforated Removable Top: 16 Gauge No. 304 Stainless Steel - No. 4 Satin Finish
- Front Apron: 18 Gauge No. 304 Stainless Steel - No. 4 Satin Finish
- End Panels/Center Gusset: 14 Gauge No. 304 Stainless Steel - No. 4 Satin Finish
- Support Gussets: (3) Fabricated from 11 Gauge Type 302-304 S/Steel With No. 4 Finish
- Plumbing/Electrical Lines are Factory Installed and Tested on all Equipment before Leaving our Manufacturing Facility

### OPTIONAL EQUIPMENT:

- Gas Cock
- Post-Mortem Scale
- Support Bracket For Scale

**VOLUME DISCOUNTS AND CONTRACT PRICING AVAILABLE**

**STAINLESS PRODUCTS CAN BE MADE TO YOUR SPECS**



## WALL MOUNTED AUTOPSY STATION Left-Hand POSITION

CAT NO.	LENGTHS
90-0320 LEFT	64", 72" and 84"

### FEATURES:

- Plumbing & Electrical Lines are Factory Installed & Tested before Leaving our Manufacturing Facility.
- Single Point Connection at Customer Location. Installation Requires a Trade Professional

### MATERIAL:

- 304 Stainless Steel Construction with a #4 finish
- Deluxe Aspirator and Vacuum Breaker with Reverse Flow for Additional Waste Removal;
- "Reverse Flow" feature instantly relieves suction clogging by providing a reverse pressure of water
- Hot and Cold Water Fixture with Convenient Gooseneck Faucet and Wrist-Blade Handles
- Spray Hose Assembly with Cold Water Control Valve, Nozzle and 10 Feet of Flexible Hose
- Heliarc Welded Seams and Joints for Uniformity; Ground and Polished to a Smooth Finish
- Large Radius on all inside Corners for easy Cleaning and Required Sanitation
- Rapid and Positive Drainage
- Large Single-Compartment Sink
- Waterproof Electrical Outlets
- 1/2 hp heavy duty commercial disposer
- Perforated stainless steel removable grids
- Waterproof Duplex GFCI Protected Electrical Outlet (Ground Fault Circuit Interrupter)
- Hot and cold water faucet with swing spout with vacuum breaker and wrist blade handles

Units customized to your specifications, Plumbing fixtures can be located in alternate positions on units

**RAISED DISSECTING AREA OPTION ALSO AVAILABLE**



## WALL MOUNTED AUTOPSY STATION Center POSITION

CAT NO.	LENGTHS
90-0330 CENTER	84", 96", 108" and 114"

### FEATURES:

- Plumbing & Electrical Lines are Factory Installed & Tested before Leaving our Manufacturing Facility.
- Single Point Connection at Customer Location. Installation Requires a Trade Professional

### MATERIAL:

- 304 Stainless Steel Construction with a #4 finish
- Deluxe Aspirator and Vacuum Breaker with Reverse Flow for Additional Waste Removal;
- "Reverse Flow" feature instantly relieves suction clogging by providing a reverse pressure of water
- Hot and Cold Water Fixture with Convenient Gooseneck Faucet and Wrist-Blade Handles
- Spray Hose Assembly with Cold Water Control Valve, Nozzle and 10 Feet of Flexible Hose
- Heliarc Welded Seams and Joints for Uniformity; Ground and Polished to a Smooth Finish
- Large Radius on all inside Corners for easy Cleaning and Required Sanitation
- Rapid and Positive Drainage
- Large Single-Compartment Sink
- Waterproof Electrical Outlets
- 1/2 hp heavy duty commercial disposer
- Perforated stainless steel removable grids
- Waterproof Duplex GFCI Protected Electrical Outlet (Ground Fault Circuit Interrupter)
- Hot and cold water faucet with swing spout with vacuum breaker and wrist blade handles

Units customized to your specifications, Plumbing fixtures can be located in alternate positions on units

## RAISED DISSECTING AREA OPTION ALSO AVAILABLE

## WALL MOUNTED AUTOPSY STATION

Right-Hand POSITION

CAT NO.	LENGTHS
90-0340 RIGHT	64", 72" and 84"

### FEATURES:

- Plumbing & Electrical Lines are Factory Installed & Tested before Leaving our Manufacturing Facility.
- Single Point Connection at Customer Location. Installation Requires a Trade Professional

### MATERIAL:

- 304 Stainless Steel Construction with a #4 finish
- Deluxe Aspirator and Vacuum Breaker with Reverse Flow for Additional Waste Removal;
- "Reverse Flow" feature instantly relieves suction clogging by providing a reverse pressure of water
- Hot and Cold Water Fixture with Convenient Gooseneck Faucet and Wrist-Blade Handles
- Spray Hose Assembly with Cold Water Control Valve, Nozzle and 10 Feet of Flexible Hose
- Heliarc Welded Seams and Joints for Uniformity; Ground and Polished to a Smooth Finish
- Large Radius on all inside Corners for easy Cleaning and Required Sanitation
- Rapid and Positive Drainage
- Large Single-Compartment Sink
- Waterproof Electrical Outlets
- 1/2 hp heavy duty commercial disposer
- Perforated stainless steel removable grids
- Waterproof Duplex GFCI Protected Electrical Outlet (Ground Fault Circuit Interrupter)
- Hot and cold water faucet with swing spout with vacuum breaker and wrist blade handles

### OPTIONAL EQUIPMENT:

- Heavy-Duty commercial disposal (3/4 hp, 1 hp)
- Dissecting Area Rinse Assembly
- Gas / Air Valves
- Post Mortem Scale with Scale Pole and Bracket
- Instrument Dissecting Tray
- Dual Exhaust Duct for connection to building ventilation system
- LED Utility Light Fixture over the work area
- Large Instrument Drawer
- Eyewash Assembly
- Florescent light fixture
- Leg assembly stainless steel



Units customized to your specifications

Plumbing fixtures can be located in alternate positions on units

Raised dissecting area option ALSO available

**RAISED DISSECTING AREA OPTION ALSO AVAILABLE**  
**STAINLESS PRODUCTS CAN BE MADE TO YOUR SPECS**



## RAISED DISSECTING AREA

The Sink Height Remains the Same While Only the Dissecting Area is Raised.  
 AVAILABLE for MODELS: 90-0320, 90-0330, and 90-0340

CAT NO.	DESCRIPTION
90-0350	Raised Dissecting Area

The Standard Height for the Dissecting Area is 34 Inches from the Floor. We are able to Increase the Standard Height for the Dissecting Area up to 40 Inches from the Floor, Increased Height Allows Taller Personnel to Work More Comfortably Since There is no Need to Bend Over to Perform Dissecting Procedures. As the Height is only increasing up to 6 Inches, Shorter Personnel can still perform all Necessary Tasks. All Body Carriers work with the Raised Dissecting Area Station.

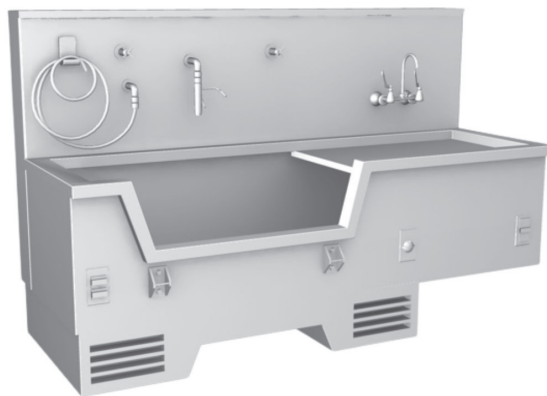

## CONNECTING SINK

Custom Fabricated to Any Size or Configuration

CAT NO.	DESCRIPTION
90-0390	Connecting Sink

The Stainless Steel Connecting Sink is used to Join two Separate Autopsy Stations. Fluid is Directed Toward the Center Sink. Adds Length to the Dissecting Area of Both Stations and Utilizes Space Which May Otherwise go Unused.





## SCRUB STATIONS

UNITS CAN BE CUSTOMIZED TO MEET YOUR SPECIFICATIONS

CAT NO.	LENGTHS
90-1250	L 40" x W 30" x H 36"

### Single Station to the Top Desk

#### FEATURES:

- Plumbing & Electrical Lines are Factory Installed & Tested before Leaving our Manufacturing Facility.
- Single Point Connection at Customer Location. Installation Requires a Trade Professional
- **MATERIAL:** 304 Stainless Steel Construction with a #4 finish
- Mixing Faucet with Gooseneck Spout and Wrist Blade Handles with Vacuum Breaker

#### OPTIONAL FEATURES:

- Hands-Free Foot Pedal for Hot/Cold Water
- Hands Free Electric Eye for Cold Water
- Hands Soap Pump
- Infrared Soap Pump



STAINLESS PRODUCTS CAN BE MADE TO YOUR SPECS

## SCRUB STATIONS

UNITS CAN BE CUSTOMIZED TO MEET YOUR SPECIFICATIONS

CAT NO.	LENGTHS
90-1252	L 60" x W 30" x H 36"

### Double Station to the Top Desk

#### FEATURES:

- Plumbing & Electrical Lines are Factory Installed & Tested before Leaving our Manufacturing Facility.
- Single Point Connection at Customer Location. Installation Requires a Trade Professional
- **MATERIAL:** 304 Stainless Steel Construction with a #4 finish
- Mixing Faucet with Gooseneck Spout and Wrist Blade Handles with Vacuum Breaker

#### OPTIONAL FEATURES:

- Hands-Free Foot Pedal for Hot/Cold Water
- Hands Free Electric Eye for Cold Water
- Hands Soap Pump
- Infrared Soap Pump



**VOLUME DISCOUNTS AND CONTRACT PRICING AVAILABLE**

## PATHOLOGY WORKSTATION, Premier

### AVAILABLE in ELEVATING or FIXED POSITION

Our Premiere Pathology Workstation available in Two Sizes: 48 Inches Long & 60 Inches Long. Station features all Stainless Steel Construction with custom height adjustments via a smooth, quiet operating electric motor. Station is ideal for a variety of users that require various height requirements. Also available in fixed height positions.

CAT NO.	DESCRIPTION
90-0760	Elevating Height
90-0762	Fixed Height

See Picture

### FEATURES:

- **MATERIAL:** 304 Stainless Steel Construction with a #4 Finish
- Mixing Faucet with Gooseneck Spout, Wrist Blade Handles with Vacuum Breaker
- **HEIGHT:** Elevating - Electric Height Adjustment with Stabilizer from 30"- 42"
- Fixed - Units are 36" High or Specified by Customer
- Designed for Easy Connection to Building Exhaust System or
- Self-Contained Our exhaust back draft design provides efficient capture of fumes across the work surface
- **SINK:** L 18" x W 14" x 10" Deep, Mixing Faucet with Gooseneck Spout, Wrist Blade Handles with Vacuum Breaker, Heavy Duty 1/2 hp Commercial Disposal with Switch and Solenoid, Spray Hose Assembly with Pressure Flexible Hose and Hand Control Valve
- Magnetic Instrument Holder
- Top Mounted LED Utility Light Fixture
- Removable Trash Container
- GFCI Two (2) Duplex Outlet with Waterproof Cover
- Formalin Container with Spigot
- C-Fold Paper Towel Holder, Stainless Steel
- Dissecting Board, Polyethylene
- Stainless Steel Specimen Rinse Basket
- Ample Light for Work Surface through a Mounted Flexible Halogen Light
- Easily Accessible Control Panel with all Necessary Functions



**Plumbing & Electrical Lines are Factory Installed & tested before Leaving our Manufacturing Facility. Single Point Connection at Customer Location. Installation Requires a Trade Professional**

### OPTIONAL EQUIPMENT:

- Monitor and Keyboard Assembly
- Basic Storage Cabinet / Flammable Storage
- Folder and Document Holder
- Additional Removable Trash Container
- Built in Table Rinse Assembly, Washes Down Surfaces Immediately
- Activated Charcoal and Potassium Filter
- Digital Camera Stand
- Hands-Free Foot Pedal for Hot/Cold Water
- Recording Device System
- Recording Device Holder/Bracket
- Perforated Grid Sections, Stainless Steel
- Hands Free Cold Water Faucet with Electric Eye Sensor
- Drawers

**STAINLESS PRODUCTS CAN BE MADE TO YOUR SPECS**

## GROSSING STATION, Free Standing

Grossing Station (CAT No. 90-0780) has the same useful features as our Free Standing Grossing Station with the added bonus of a larger sink basin. Available Two Sizes: 48 Inches Long & 60 Inches Long. The larger sink basin allows the unit to be equipped with an optional disposal unit

CAT NO.	DESCRIPTION
90-0770	Grossing Station



## Free Standing, See Picture

### FEATURES:

- **MATERIAL:** 304 Stainless Steel Construction with a #4 Finish
- **SINK:** L 18" x W 14" x 10" Deep, Mixing Faucet with Gooseneck Spout, Wrist Blade Handles with Vacuum Breaker
- Spray Hose Assembly with Pressure Flexible Hose and Hand Control Valve with vacuum Breaker
- Magnetic Instrument Holder
- Designed for Easy Connection to Building Exhaust System or Self-Contained Our exhaust back draft design provides
- work surface
- Work surface height 36"
- Powerful Variable Speed Exhaust System with Full Width Exhaust Grill
- Incandescent Lights with 3X Magnifier Mounted on Flexible Arms
- GFCI Two (2) Duplex Outlet with Waterproof Cover
- Formalin Container with Spigot
- C-Fold Paper Towel Holder, Stainless Steel
- Dissecting Board, Polyethylene
- Ample Light for Work Surface through a Mounted Flexible Halogen Light
- Easily Accessible Control Panel with all Necessary Functions

**Plumbing & Electrical Lines are Factory Installed & tested before Leaving our Manufacturing Facility. Single Point Connection at Customer Location. Installation Requires a Trade Professional**

### OPTIONAL EQUIPMENT:

- Monitor and Keyboard Assembly
- Basic Storage Cabinet / Flammable Storage
- Folder and Document Holder
- Additional Removable Trash Container
- Heavy Duty 1/2 hp, 3/4 hp or 1 hp commercial disposal with switch and solenoid
- Built in Table Rinse Assembly, Washes Down Surfaces Immediately
- Activated Charcoal and Potassium Filter
- Digital Camera Stand
- Hands-Free Foot Pedal for Hot/Cold Water
- Recording Device System
- Recording Device Holder/Bracket
- Perforated Grid Sections, Stainless Steel
- Hands Free Cold Water Faucet with Electric Eye Sensor
- Drawers

**VOLUME DISCOUNTS AND CONTRACT PRICING AVAILABLE**

## GROSSING STATION BENCH TOP

DESIGNED to DROP DIRECTLY onto your COUNTER or BENCH TOP  
Available in Two Sizes: 48 Inches Long & 60 Inches Long

CAT NO.

90-0774



### FEATURES:

- Designed to drop on bench top lowered to the counter
- All 304 stainless steel construction with #4 finish
- Designed for connection to building exhaust system or self-contained
- Our exhaust back draft design provides efficient capture of fumes across the work surface
- **Sink:** 18" Long x 14" Wide x 10" Deep
- Mixing faucet with gooseneck spout and wrist blade handles with vacuum breaker
- Spray Hose Assembly with pressure flexible hose and hand control valve
- Magnetic instrument holder
- Top mounted LED Utility light fixture
- Ample light for work surface through mounted flexible halogen light
- All water systems protected by vacuum breakers
- GFCI duplex outlet with waterproof cover
- C-fold paper towel holder, stainless steel
- Available in two sizes: 48 inches long and 60 inches long
- Plumbing and Electrical lines factory installed. Single point connection at customer location. May require a trade professional at customers location

### OPTIONAL FEATURES:

- Monitor and keyboard assembly
- Basic storage cabinet / flammable storage
- Folder and document holder
- Removable trash container
- Built in table rinse assembly washes down surfaces immediately
- Activated Charcoal and Potassium Filter
- Digitally camera stand
- Hands-free foot pedal for hot/cold water
- Recording device system
- Recording device holder/bracket
- Stainless steel perforated grid sections
- Hands free cold water faucet w/ electric eye sensor

**STAINLESS PRODUCTS CAN BE MADE TO YOUR SPECS**

## GROSSING STATION, WALL MOUNTED

An Efficient Space Saving Pathology Workstation, all the necessary fixtures & accessories to perform routine procedures. Unit is similar to our Basic Grossing Station (CAT NO. 90-0776). The Station has the added benefit of formaldehyde fume removal. Two, 2-speed fans exhaust fumes through filter cartridges which break down the harmful vapors into carbon dioxide and water.

CAT NO.

90-0778

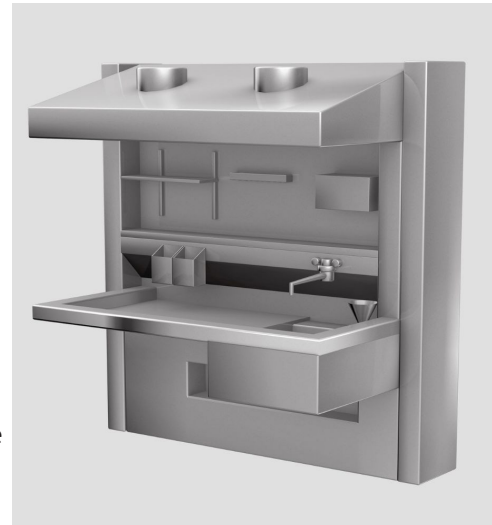

### FEATURES:

- Available in TWO SIZES: 48 Inches & 60 Inches Long
- **MATERIAL:** 304 stainless steel construction with #4 finish
- Designed for Easy Connection to Building Exhaust System or Self-Contained Our exhaust back draft design provides efficient capture of fumes across the work surface
- **Sink:** 18" Long x 14" Wide x 10" Deep
- Mixing faucet with gooseneck spout and wrist, blade handles with vacuum breaker
- Spray Hose Assembly with pressure flexible hose and hand control valve
- Magnetic instrument holder
- Top mounted fluorescent light fixture, Ample light for work surface through a mounted
- Flexible halogen light
- All water systems protected by vacuum breakers
- GFCI duplex outlet with waterproof cover
- C-fold paper towel holder, stainless steel

### OPTIONAL EQUIPMENT:

- Monitor and keyboard assembly
- Basic storage cabinet / flammable storage
- Folder and document holder
- Removable trash container
- Built in table rinse assembly washes down surfaces immediately
- Activated Charcoal and Potassium Filter
- Digital camera stand
- Heavy Duty 1/2 hp, 3/4 hp or 1 hp commercial disposal with switch and solenoid
- Hands-free foot pedal for hot/cold water
- Hands free electric eye for cold water
- Recording device system
- Recording device holder/bracket
- Stainless steel perforated grid sections

**VOLUME DISCOUNTS AND CONTRACT PRICING AVAILABLE**



## GROSSING WORK BENCH, Premier

AVAILABLE in ELEVATING or FIXED POSITION

Work Bench features all Stainless Steel Construction with optional custom height adjustment via a smooth, quiet operating electric motor. Station is ideal for a variety of users that require various height requirements. Also available in fixed height positions.

CAT NO.

90-0780



### FEATURES:

- **MATERIAL:** All 304 Stainless Steel Construction with #4 finish
- **SIZE:** L 60" x W 30" x H 36" Height Fixed or Specified by Customer
- **HEIGHT:** Elevating - Electric Height Adjustment with Stabilizer from 30" - 42"
- Fixed - Units are 36" High or Specified by Customer
- **Sink:** 16" Long x 14" Wide x 8" Deep
- Mixing faucet with gooseneck spout and wrist blade handles with vacuum breaker
- GFCI duplex outlet with waterproof cover
- Hands-free foot pedal controls to activate the cold/hot water faucet
- Three removable Stainless steel perforated grid sections
- All water systems protected by vacuum breakers
- Magnetic instrument holder
- Plumbing & Electrical Lines are Factory Installed & tested before Leaving our Manufacturing Facility. Single Point Connection at Customer Location. Installation Requires a Trade Professional

### OPTIONAL EQUIPMENT:

- Dowlndraft design for capturing fumes at work station
- Activated Charcoal and Potassium Filter for Back draft
- Formalin dispensing system
- Built in table rinse assembly washes down surfaces immediately
- Hands free cold water faucet w/ electric eye sensor
- Folder and document holder
- Removable trash container

## BACK DRAFT PATHOLOGY WORKSTATION

IDEAL for a VARIETY of LABORATORY USES

Our Back Draft Pathology Workstation is ideal for a variety of laboratory uses requiring fume control. A versatile system that may be designed to connect to any ventilation system.

CAT NO.

90-0782



### FEATURES:

- Available in Two Sizes: 48 Inches Long & 60 Inches Long
- Work Surface Height: 36"
- **MATERIAL:** All 304 Stainless Steel Construction with #4 finish
- Mixing faucet with gooseneck spout and wrist blade handles with vacuum breaker
- Powerful variable speed exhaust system with full width exhaust grill, Designed for connection to building exhaust system or self-contained, Our exhaust back draft design provides efficient capture of fumes across the work surface
- All water systems protected by vacuum breakers
- Spray Hose Assembly with pressure flexible hose and hand control valve
- Easily accessible control panel with all necessary functions
- GFCI duplex outlet with waterproof cover
- Dissecting Board, Polyethylene

### OPTIONAL EQUIPMENT:

- Sink may be configured on Left or Right or Center side
- Folder and document holder
- Removable trash container
- Built in table rinse assembly washes down surfaces immediately
- Activated Charcoal and Potassium Filter
- Hands-free foot pedal for hot/cold water
- Hands free cold water faucet w/ electric eye sensor
- Recording device system
- Recording device holder/bracket
- Stainless steel removable perforated grid sections
- Heavy Duty 1/2 hp, 3/4 hp or 1 hp commercial disposal with switch and solenoid
- Mounted Window Shield for facial protection
- Formalin container with spigot
- Cabinet

Plumbing & Electrical Lines are Factory Installed & Tested before Leaving our Manufacturing Facility. Single Point Connection at Customer Location. Installation Requires a Trade Professional

**STAINLESS PRODUCTS CAN BE MADE TO YOUR SPECS**

## EVIDENCE DRYING CABINETS

**“SIMPLY THE BEST IN THE MARKET FOR THE MONEY”**

CAT NO.	DESCRIPTION
90-0766	Lockable Door
90-0768	Without Door

Ideal for every facility, our Evidence Drying Cabinets are an easy solution for every facility which handles forensic cases, it provides safe storage of evidence, prevents cross contamination, and is reasonably priced to purchase several. Made with 304 stainless steel. Available with & without Door.

### FEATURES:

- Can be wash down with decontaminating soap
- Cabinets can easily be stacked next to each other
- Lockable door easily secured with padlock (padlock not included)
- Removable drawer has 5 shelf positions
- Evidence/property can be put in on top self and in removable drawer
- Clothes can be hung in two positions
- Four (4) lockable swivel casters for easy maneuverability
- Dries evidence in a safe controlled environment



## FUME HOOD MODULES

The Aluminum Frame Fume Hood Modules are universally used for the safe handling of chemical fumes. Ductless Fume Hoods provide wide spectrum filtration for finite quantities of nonexplosive solids, liquids and gases, thus eliminating the need for venting and expensive duct work. This system is ideally suited for laboratories as well as cleanrooms. This versatile piece of equipment can solve many difficult, and sometimes conflicting, air quality requirements. Our Fume Hoods are available in (3) different sizes and may be manufactured to fit your specific needs.

### FEATURES:

- Modules available with 1-3 ventilation units and may be custom manufactured
- Sides and front are made with clear acrylic that protects against most chemicals
- Replaceable particle and charcoal filters

### OPTIONAL FEATURES:

- FUME HOOD EXHAUST MODULE / ADAPTER & FILTERS
- Exhaust Module
- Particle Filter
- Potassium Permanganate Filter
- Charcoal Filter
- Ventilation Adapter

CAT NO.	DESCRIPTION	SIZE
90-0796	1 Module Ventilation Unit	L 24" x H 20" x W 20.5"
90-0797	2 Module Ventilation Unit	L 48" x H 20" x W 20.5"
90-0798	3 Module Ventilation Unit	L 72" x H 20" x W 20.5"

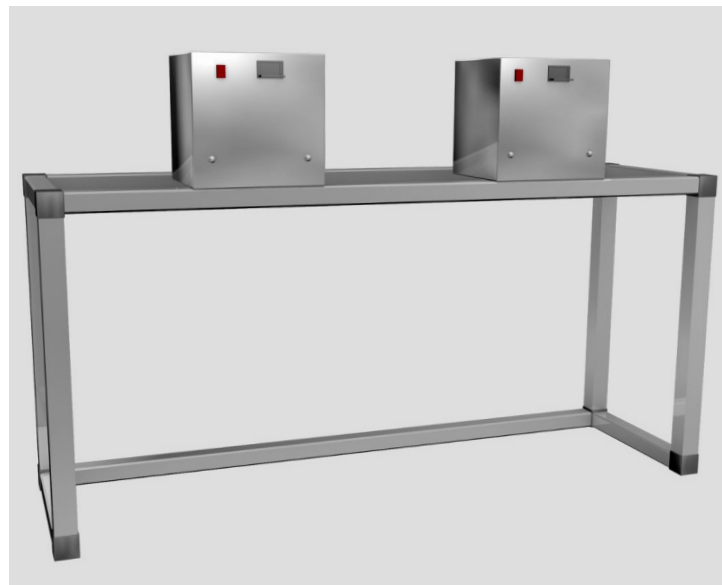

## TWO BODY STORAGE CARRIER

DESIGNED TO MAXIMIZE SPACE, Our Two Body Storage Carrier is designed to hold two bodies with Our Stainless Steel Standard Body Tray (Sold separately Cat No. 90-0670). Easily movable, with four 6" diameter rigid casters all with brake mechanism. Fabricated with 11 gauge, 304 Stainless Steel with #4 Finish for Heavy-duty Use. All Welding is a continuous bead. Trays are easily removable when used in conjunction with each other, provides an economical and convenient means of storing cadavers.

### Weight Capacity is 325 lbs per Level

CAT NO.	DESIGN LOAD
90-0582	Two Body Storage Carrier
90-0670	Body Tray
90-0670HS	Body Tray with Handslots (Trays Sold Separately)



### OPTIONAL ACCESSORIES:

Stainless Steel Standard Body Tray

CAT NO.	DESCRIPTION
90-0670	BODY TRAY
90-0670HS	BODY TRAY with HANDSLOTS

All Inside Corners are Smoothly Finished for easy Cleaning. All Edges are Rolled and Welded for extra Strength and Easy Handling, Fabricated with or without Hand Slots.



## CANTILEVER STORAGE RACKS

CAT NO.	DESCRIPTION
90-1000	2 TIER
90-1001	3 TIER
90-1002	4 TIER
90-1004	5 TIER



ALL OF OUR TRAYS FIT THE CANTILEVER

Our stainless steel Cantilever Units are designed to hold operating platforms and provide space saving cold storage convenience. The units are generally custom fabricated to accommodate efficient utilization of space. The Cantilever arms are 11 gauge, 304 stainless steel with No. 4 finish welded to the vertical columns. Each tier will support 500 lbs. The Cantilever storage units are equipped with leveling floor supports. The fabrication emphasizes clean, sanitary construction. Rubber bumpers to protect cadaver tray.

## CANTILEVER STORAGE RACK with CASTER

supports up to 500 lbs per level

CAT NO.	DESCRIPTION
90-1008	2 TIER
90-1010	3 TIER
90-1012	4 TIER
90-1014	5 TIER



ALL OF OUR TRAYS FIT THE CANTILEVER

Our Stainless Steel Cantilever Storage Rack is designed to support up to 500 (lbs) pounds per level in a free-standing position. Casters allow mobility for transport or cleaning purposes. These racks are designed for heavy-duty use. Spec's similar to 90-1000. Cantilever arms, vertical arms and cross supports are fabricated of 11 gauge, 304 stainless steel with a No. 4 satin finish. Heavy-duty 6" or 4" diameter casters. Rubber bumpers to protect cadaver tray.



**POWDER COATED CANTILEVER STORAGE RACK with CASTERS**

CAT NO.	DESCRIPTION
90-1010PC	3 TIER
90-1012PC	4 TIER
90-1014PC	5 TIER



ALL OF OUR TRAYS FIT THE CANTILEVER

Our Stainless Steel Powder Coated Cantilever Storage Rack is designed to support up to 500 (lbs) pounds per level in a free-standing position. Casters allow mobility for transport or cleaning purposes. These racks are designed for heavy-duty use. Spec's similar to 90-1000. Cantilever arms, vertical arms and cross supports are fabricated of 11 gauge, 304 stainless steel with a No. 4 satin finish. Heavy-duty 6" or 4" diameter casters. Rubber bumpers to protect cadaver tray.

**CANTILEVER STORAGE ADJUSTABLE RACK**

CAT NO.	DESCRIPTION
90-1002ADJ	4 TIER
90-1004ADJ	5 TIER
90-1012ADJ	4 TIER with CASTERS



ALL OF OUR TRAYS FIT THE CANTILEVER

Our stainless steel Cantilever Units are designed to hold operating platforms and provide space saving cold storage convenience. The units are generally custom fabricated to accommodate efficient utilization of space. The Cantilever arms are 11 gauge, 304 stainless steel with No. 4 finish and adjustable for your preferred height. Each tier will support 500 lbs. The Cantilever storage units are equipped with leveling floor supports. The fabrication emphasizes clean, sanitary construction. Rubber bumpers to protect cadaver tray.

## PORTABLE MORTUARY STORAGE RACK

Ideal for for a variety of cadaver storage applications

Our portable mortuary storage rack is used with our stainless steel standard body trays (sold separately, CAT NO: 90-0670 or 90-0670HS) more compact than conventional cantilever storage units allowing for greater storage capacity without increasing space. Can also be used in the total roll system adding even more versatility.

CAT NO.	DESCRIPTION
90-1020	2 TIER
90-1022	3 TIER
90-1024	4 TIER
90-1026	5 TIER
90-1026PC	5 TIER (POWDER COATED)

### FEATURES:

- Fabricated from 1 ½" heavy 11 gauge, 304 stainless steel with #4 finish
- Smoothly Finished for easy Cleaning
- Heavy-duty swivel 6" casters, all with brake mechanism, allow for ease of movement
- Roller assemblies mounted in each bay make loading and unloading quite easy

### ACCESSORIES:

Standard Body Tray

CAT NO. 90-0670, 90-0670HS

available with or without handslots



## MOBILE CREMATION STORAGE RACK

Our Mobile Cremation Rack was specifically designed to handle a variety of cadaver storage applications in an area less than the conventional cantilever storage systems. Fabrication is from heavy 1 ½" 11 gauge, 304 stainless steel with #4 finish tubing. Fitted with four 6" diameter casters all with a braking mechanism. Each rack is fitted with 5 rolling cross bars allowing for easy loading and unloading. With roller assemblies provide easy loading and unloading of cadavers. To complete the system, all of our storage racks can be fitted with a roller carriage to accept the standard body trays.

CAT NO.	DESCRIPTION
90-1021	2 TIER
90-1023	3 TIER
90-1025	4 TIER
90-1027	5 TIER



**MORTUARY STORAGE RACK SYSTEM**

Storage Units Allow for Greater Storage Capacity without Increasing Space

CAT NO.	DIMENSION
90-1030	L 77 ½" x W 23 ⅛" x H 2 ¾"

Our Portable Mortuary Storage Rack System (CAT No. 90-1030) is used in conjunction with our stainless steel standard body trays (Sold Separately, CAT No's. 90-0670, 90-0670HS available with or without handslots) are ideal for a variety of cadaver storage applications.

The Mortuary Storage Rack System is more compact than conventional cantilever storage units allowing for greater storage capacity without increasing space.

Can also be used in the Total Roll System adding even more versatility. The Mortuary Storage Rack unit is fabricated from 1 ½" heavy 11 gauge, 304 stainless steel with #4 finish. Heavy-duty 5" swivel casters, all with brake mechanism, allow for effortless movement.

Roller assemblies mounted in each bay make loading and unloading the cadaver tray quite easy.



**STAINLESS PRODUCTS CAN BE MADE TO YOUR SPECS**

## FEATURES:

- Fabricated from 1 ½" square, 11 gauge, 304 #4 finish Stainless steel tubing
- Heavy gauge material provides sturdy and reliable service
- Single piece construction allows ease in assembly, disassembly and relocation
- Free standing or attached to the building
- Adjustable leveling pads
- Rubber bumpers provided at contact points to cushion the tray when loading
- Available in heights from two to eight bays and lengths from one column to virtually any length the customer requires
- Maintenance-free nylon roller assemblies (10 per bay)
- Safety flaps on both sides of tray
- Stainless Steel Standard Body Trays (Sold Separately, CAT No's. 90-0670, 90-0670HS available with or without handslots)

CAT NO.	DIMENSION
90-1030	Mortuary Storage Rack System Available in Heights from two to eight bays Lengths from one column to virtually any length the customer requires
90-0670	Standard Body Tray Trays Sold Separately Available with or without handslots Dimensions: L 77 ½" x W 23 ⅛" x H 2 ¾"

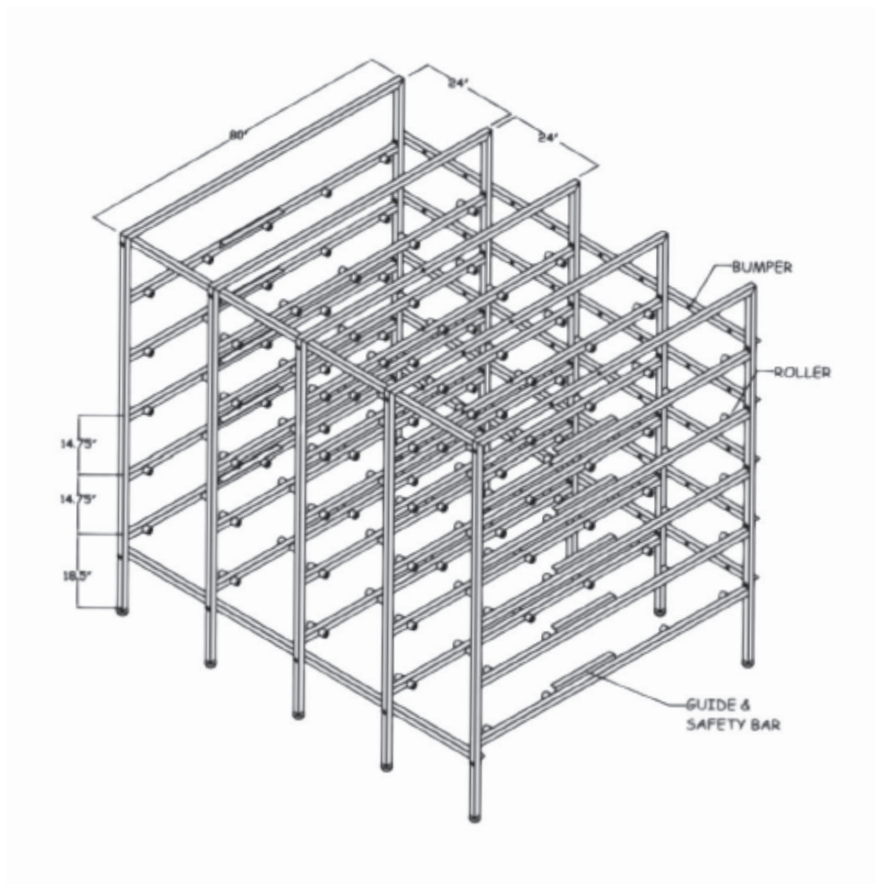



**CADAVER PALLET TRUCK**

FUNCTIONAL ROBUST &amp; DEPENDABLE

CAT NO.	WIDTH	FORK LENGTH
80-1636	15.8"	36"
80-1842	17.7"	42"
80-1848	17.7"	48"
80-2036	20.5"	36"
80-2042	20.5"	42"
80-2048	20.5"	48"
80-2736	27"	36"
80-2742	27"	42"
80-2748	27"	48"
80-2754	27"	54"
80-2760	27"	60"
80-2772	27"	72"

SPECIFICATIONS	
Capacity	5,000 lbs
Fork Width	6.3"
Width	27"
Length	48"
Wheels	Polyurethane

**Fork Assembly**

A deep, low-profile frame cross brace between the forks and steel lift link arms adds durability. A 2.9" lowered fork height improves pallet entry. A dual entry-exit system that combines rollers and ramps that assists for pallet entry and exit.

**Control Handle**

An ergonomic handle featuring optimum handle thickness and angled shape delivers fatigue-free operation. Features a three-position lever (raise, lower and neutral). The neutral position allows for free movement of the handle in horizontal travel without hydraulic resistance.

**Steering**

Articulated steering wheels enhance durability and increase load handling and control, especially on uneven surfaces. Steering wheels rotate through a 200 degree range for easy maneuvering in tight spaces.

**Chassis**

Steel forks feature a C-channel design for maximum strength and long-term durability.

## HAND CRANK CADAVER LIFT

SPECIFICATIONS	
Height Stowed:	78.5"
Length Stowed: 29"	6.3"
Height Maximum:	117"
Length Operating:	59.5"
Leg Width Minimum:	31.5"
Leg Width Maximum:	58"
Minimum fork spread:	11.5"
Maximum fork spread:	30"
Ground Clearance:	2"

**CAT NO.**  
80-1110

The hand cranked heavy duty cadaver lift is a manually operated lift, non-slip quiet winch and load handling options to create just the lift you need. The compact, portable design rolls through standard single doorways in the upright position.

### Easy to Maneuver and Store

The unit sets up quickly without any tools and is ready to go to work in seconds. The rear transport wheel also allows maneuverability on uneven surfaces. Legs fold up and attachments are removable for easy storage and loading.

### Extreme Durability

The patented, field-proven telescoping mast system is compact, strong and rigid.





## CADAVER PALLET ROLLER ASSEMBLY

### FEATURES:

- All 304 stainless steel construction with #4 finish, heavy duty 11 gauge tubing
- 10 nylon maintenance rollers for easy transfers
- Tray locks on both sides, so the tray can be removed from both sides
- Fits all of our cadaver lifts

**CAT NO.**

80-1120



## SPREADER BARS WITH STRAPS

### FEATURES:

- Straps attach to the hand slots of standard body tray- 90-0670HS (sold separately)
- Spreader bars made with stainless steel and nylon straps
- Weight Capacity: 1,000 lbs.

**CAT NO.**

80-1122



## CADAVER LIFT BODY ASSEMBLY

### FEATURES:

- All 304 stainless steel construction with #4 finish, heavy duty
- 11 gauge 1 1/2" tubing
- (4) nylon adjustable straps
- Weight capacity: 1,000 lbs.
- Fits all of our cadaver lifts

**CAT NO.**

80-1124

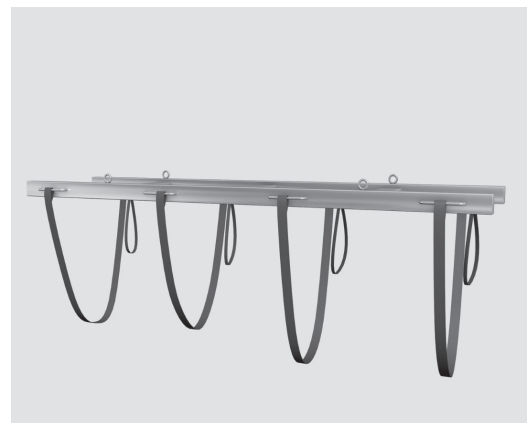

## CADAVER SCISSOR LIFT

SPECIFICATIONS	
Width	30"
Length	93"
Collapsed Height	13.5"
Extended Height	74"
Weight Capacity	750 lbs.

**CAT NO.**  
80-1130



### FEATURES:

- Hydraulic scissor action lifting system
- Highly maneuverable, easy to operate eliminates need for manual lifting
- Accommodates various body trays including our Bariatric trays from 23" to 32" wide with flat bottoms
- Adjustable height for moving laden body trays between storage room and autopsy tables, etc
- Height extends from a minimum height of 13.5" to 74"
- Battery operated hydraulic lift, supplied with integral battery charger for a direct connection to a standard electrical outlet
- All 304 stainless steel heavy duty tubular section with #4 finish
- Trays can be removed from all four sides
- Rollers and roller balls allow effortless body tray transfers

## CADAVER FORKLIFT Push Type

SPECIFICATIONS	
Load Capacity	1,000 lbs.
Raised Height	61 7/8" : 84" Forks Inverted
Lowered Height	1" : 23 7/8" Forks Inverted
Dimensions H/W/L	83 1/2" / 61 3/8" X 30" X 46 3/16"
Base Legs I.D. / O.D.	22 1/8" X 30"
Wheel Dia. Front/Rear	2 1/2" / 4"

## CAT NO.

80-1222

## FEATURES:

- 15" load centers
- Solid steel, adjustable width forks
- Fixed or telescoping mast
- Tighter turning radius than conventional fork lifts
- Flow control valve for smooth lowering
- 5" per second lifting speed
- Heavy-duty battery and built-in charger
- High impact phenolic load wheels
- 12V DC battery or 110V AC unit available



## CADAVER FORKLIFT POWER DRIVE, Push Type Stacker

SPECIFICATIONS	
Load Capacity	1,000 lbs.
Raised Height	61 7/8" : 84" Forks Inverted
Lowered Height	1" : 23 7/8" Forks Inverted
Dimensions H/W/L	83 1/2" / 61 3/8" X 30" X 46 3/16"
Base Legs I.D. / O.D.	22 1/8" X 30"
Wheel Dia. Front/Rear	2 1/2" / 4"

### CAT NO.

80-1224-PD

### FEATURES:

- 15" load centers
- Solid steel, adjustable width forks
- Fixed or telescoping mast
- Tighter turning radius than conventional fork lifts
- Flow control valve for smooth lowering
- 5" per second lifting speed
- Heavy-duty battery and built-in charger
- High impact phenolic load wheels
- 12V DC battery or 110V AC unit available
- Power drive option available



**A**

Adson Dressing Forceps	36
Adson Tissue Forceps	36
Allis Dry Dissector	54
Allis Tissue Forceps	36
All Purpose Utility Scissors	28
Aneurysm Needle	54, 57
Angular Jaw Forceps	39
Apron	105, 107, 110
Arbors	2
Aspirators	138, 139
Autopsy Carrier With Grid Plates	171
Autopsy & Cast Saw Repairs	4
Autopsy Saw	1
Autopsy Saw Blades	2
Autopsy Sink Strainer	137
Autopsy Sink Station	203-210
Autopsy Tables	195-202

**B**

Baby Scale	97 - 98
Ballenger Sponge Forceps	37
Bariatric Autopsy Carrier	172
Bayonet Thumb Forceps	35
Biohazard Liners	74
Blade Remover	10
Blumenthal Rongeur	40
Body Board	158, 164
Body Scoop	158
Bone Dust Collector	4, 6
Bone Mallet (Lead Filled)	49
Bone Mallet (Steel)	49
Bone Saw	42-43
Brun's Metacarpel Saw	42
Gigli Handles and Wire Saw	43
Langenbeck Metacarpel Saw	42
Rib Cutting Knife	43
Satterlee's Bone Saw	42
Boot Covers	113-114, 116
Bouffant Cap	105, 107
Bowl	70
Broad Point Thumb/Dressing Forceps	31
Brown Adson Tissue Forceps	32
Brown Tissue Forceps	32
Brunetti's Chisel With Guard	51
Brun's Metacarpel Saw	42
Bullet Probes	56

**C**

Cadaver Bags	123 - 133
Economy Vinyl	125
Environmentally Friendly	126
Heavy Duty	130
Heavy Vinyl	127
Jumbo Super Heavy	131
Medium Weight	128

Super Medium Weight	129
Next Generation	132
Water Recovery	133
Cadaver Lift Body Assembly	229
Cadaver Lifts	227 - 232
Cadaver Pallet Roller Assembly	229
Cadaver Scissor Lift	230
Calipers	63
Canners And Handlers Gloves	121
Cantilever Storage Racks	222
C-Arm Autopsy Carrier	173
Carriers	167 - 183
Autopsy Carrier With Grid Plates	171
Bariatric Autopsy Carrier	172
C-Arm Autopsy Carrier	173
Carrier With Rollers	179
Covered Cadaver Carrier	184
Economy Carrier	169
Elevated Autopsy Cart	177 - 178
Hydraulic Carrier for Plastic Tray	182
Hydraulic Autopsy Carrier	180 - 181
Standard Carrier	168
Stretcher - Cadaver Chassis	176
Two Body Storage Carrier	174 - 175
Universal Carrier	167
Carrier With Rollers	179
Carts	85 - 86, 177 - 178
Chisels	51
Cilia Thumb Forceps	33
Clamps	52
English Pattern Tube Occluding Clamp	52
Presbyterian Tube Occluding Clamp	52
St. Vincent's Tube Occluding Clamps	52
Tube Occluding Clamps	52
Cleaning Brush	72
Cleaning Supplies	72
Combination Hydro Aspirator	139
Constable Rib Shears	46
Containers	81 - 82
Costume, 8"	44
Cot	141 - 150
Cot Cover	151 - 152
Councilman Rib Shear	46
Councilman's Chisel	51
Coverall	106 - 109
Covered Cadaver Carrier	183 - 184
Coverglass Forceps	35
Cutting	44

**D**

Deaver Retractors	60
Deodorizers	72
Dial Hanging Scales	90
Disaster Pouches	123 - 133
Dissecting Boards	164
Dissecting Kits	61 - 62
Dissecting Table	159 - 163
Dissecting Tenaculum	54



Dissection Cart	159, 194	Thumb Forceps With Magnifier	35
Dissectors	54	Tissue Forceps	29 - 30
Allis Dry Dissector	54	Friedman Rongeurs	40
Aneurysm Needle (Broad Handle)	54	Fume Hood Modules	220
Dissecting Tenaculum	54		
Doyen Abdominal Scissors	25	<b>G</b>	
Dressing Forceps, Potts-Smith	37	Gannet's Post Mortem Knife	15
Dressing Forceps With Guide Pin	39	Gauntlet Stainless Steel Glove	121
Dressing Table	155 - 156	GenPro Heat Sealed Seams	113
Dublin Model Knife	15	Gerald Dressing Forceps	36
Dubois Decapitation Scissors	25	Gerald Tissue Forceps	32
Dura Strip Forceps	37	Gigli Handles And Wire Saw	43
		Gillies Skin Hook	53
<b>E</b>		Gloves	117 - 122
Economy Carrier	169	Gluck Rib Shears	47
Economy Vinyl Disaster Pouches	125	Gowns	111 - 112
Electric Autopsy Saw	1	Grooved Director	55
Elevated Autopsy Cart	177 - 178		
Embalming Stations	203 - 206	<b>H</b>	
English Pattern Tube Occluding Clamp	52	Halstead's Mosquito Forceps	38
Enterotomy Scissors	25	Hammer - Mallets	49
Environmentally Friendly	126	Bone Mallet (Lead Filled)	49
Evidence Drying Cabinets	219	Bone Mallet (Steel)	49
Exam Gloves	117 - 122	Hammer With Hook	49
Extraction Hose	5	Hamper Stand	73
		Handles	7, 8
<b>F</b>		Hanging Scales	89 - 91
Face Masks	101 - 104	Harrington Scissors	26
Face Shields	102, 104	Hartman Rongeur	40
Flesh Hook	53	Headblock	165
Foerster Dressing Forceps	39	Hoke Osteotome	50
Foerster Iris Tissue Forceps	34	Hood	105 - 107, 109
Folding Operating Table	153	Hooks	53
Forceps	29 - 39	Flesh Hook	53
Adson Dressing Forceps	36	Gillies Skin Hook	53
Adson Tissue Forceps	36	Triple Chain Hook, 6"	53
Allis Tissue Forceps	36	Hydraulic Autopsy Carrier	180 - 181
Angular Jaw Forceps	39	Hydraulic Carrier For Plastic Tray	182
Ballenger Sponge Forceps	37	Hydro Aspirator	139
Bayonet Thumb Forceps	35	Hydro Aspirator Extension	139
Broad Point Thumb/Dressing Forceps	31	Hypodermic Needles	79 - 80
Brown Adson Tissue Forceps	32		
Cilia Thumb Forceps	33	<b>I</b>	
Coverglass Forceps	35	ID Bands	135 - 136
Dressing Forceps, Potts-Smith	37	Immersion Dissecting Table	161
Dressing Forceps With Guide Pin	39	Instrument Cleaning Brush	72
Dura Strip Forceps	37	Instrument Drying Trays	67
Foerster Dressing Forceps	39	Instrument Trays	65 - 68
Foerster Iris Tissue Forceps	34	Iris Scissors	18
Gerald Dressing Forceps	36		
Gerald Tissue Forceps	32	<b>J</b>	
Halstead's Mosquito Forceps	38	Janazah Body Carrier	185
Kelly's Forceps	38	Jaw Spreader	45
Kuhne Coverglass Forceps	35		
Martin Tissue Forceps	33	<b>K</b>	
Russian Tissue Forceps	34	Kelly's Forceps	38
Specimen/Bottle Forceps	33	Kern Bone Holding Forceps	50
		Kick Bucket	70, 165



Knife	11 - 15	Pathology Evidence Drying Cabinets	219
Knife Sharpener	16	Pathology Grossing Stations	213 - 218
Knives	11 - 15	Pick's Myelotome	44
Kuhne Coverglass Forceps	35	Plain Bone Shears	46
Kut-Gard	122	Plastic Carrier	169, 170, 173, 174, 182, 187, 191
Kut-Gard Gloves	122	Platform Scale	99 - 100
<b>L</b>		Poly Gown	111
Ladles	71	Portable Mortuary Storage	223
Lambotte's Osteotome	50	Post Aspirator	138
Langenbeck Metacarpal Saw	42	Post Mortem Aspirator	138
Large Sectioned Blade	2	Post Mortem Knife	14 - 15
Model No. 201-102	2	Post Mortem Knife, Double Edge	15
Leg Support	165	Post Mortem Knife, Extra Heavy	15
Liners	73 - 74	Post Mortem Stapler	76
Lister Bandage Scissors	26	Post Mortem Surgical Needles	75
Liston Amputating Knives	14	Pouches	123 - 133
Liston Bone Cutting Forceps	47	Pouch Locks	136
<b>M</b>		Powder Coated Cantilever Storage Racks	222
Macro-Prep Knives	12	Premium Dissecting Knives	13
Martin Tissue Forceps	33	Presbyterian Tube Occluding Clamp	52
Masks	101 - 104	Probes	55 - 56
Mayo Dissecting Scissors	22	<b>Q</b>	
Mayo-Noble Dissecting Scissors	23	Qlicksmart Blade Remover	10
Mayo Scissors	17 - 18	<b>R</b>	
Measures	69	Rachiotome	44
Measuring Mat	97	Ratcliff	14
Measuring Tape	63	Retractors	58 - 60
Metzenbaum Scissors	17 - 18, 24	Deaver Retractors	60
Microtome Object Disc	57	Richardson - Eastmen Retractors	60
Mini Blumenthal Rongeur	40	Richardson Retractors, Hollow Grip Handle	60
Mobile Cremation Storage	224	Senn (Miller) Retractor	58
Mortuary Cot	141 - 150	Tracheal Retractors	58
<b>N</b>		US Army Retractors	58
Needle Injector	137	Weitlaner Retractors	59
Needles, Hypodermic	79 - 80	Rib Cutting Knife	43
Nitrile Gloves	117 - 118, 120	Rib Shears	46 - 47
<b>O</b>		Constable Rib Shears	46
Operating Tables	153 - 154	Councilman Rib Shears	46
Osteotomes	50	Gluck Rib Shears	47
Osteotomes - Chisels	50	Liston Bone Cutting Forceps	47
Brunetti's Chisel With Guard	51	Plain Bone Shears	46
Councilman's Chisel	51	Richardson - Eastman Retractors	60
U.S. Army Pattern Chisel	51	Richardson Retractors, Hollow Grip Handle	60
U.S. Army Pattern Gouge	51	Richter Dissecting Scissors	28
Osteotomes - Forceps	50	Roger Wire Scissors	27
Hoke Osteotome	50	Rongeur	40 - 41
Lambotte's Osteotome	50	Blumenthal Rongeur	40
U.S. Army Pattern Osteotomes	50	Friedman Rongeur	40
Kern Bone Holding Forceps	50	Hartmen Rongeur	40
<b>P</b>		Mini Blumenthal Rongeur	40
Pails	70, 165	Ruskin Rongeur	41
		Side Cutting Rongeur	41
		Round Autopsy Blade	2
		Rulers	64
		Ruskin Rongeur	41
		Russian Tissue Forceps	34

## S

Satterlee's Bone Saw	42
Saw Blades	2
Scale Hanger	87 - 88
Scales	87 - 100
Scalpel Blades	8 - 9
Scalpel Handles	7 - 8
Scalpel Handles & Blades	7 - 9
Scalpels With Handles	8
Scissors	17 - 28
All Purpose Utility Scissors	28
Doyen Abdominal Scissors	25
Dubois Decapitation Scissors	25
Enterotomy Scissors	25
Harrington Scissors	26
Iris Scissors	17, 18, 27
Lister Bandage Scissors	26
Mayo Dissecting Scissors	22
Mayo-Noble Dissecting Scissors	23
Mayo Scissors	17 - 18
Metzenbaum Scissors	17, 18, 24
Richter Dissecting Scissors	28
Roger Wire Scissors	27
Spencer Suture Scissors	28
Tungsten Carbide Scissors	18
Vezien's Abdominal Scissors	28
Scrub Stations	211 - 212
Senn (Miller) Retractor	58
Sharpeners	16
Dickoron Steel, Knife Sharpener	16
Eze-lap Diamond Steel, Knife Sharpener	16
Electric Scissors Sharpener, ScissorsPro	16
Knife Sharpener, AngleSelect™ Diamond Hone™	16
Shoe Covers	113, 115, 116
Shrouds	134
Skin Markers	76
Sleeves	105, 107, 109, 110
Specimen/Bottle Forceps	33
Specimen Containers	82
Specimen Knife (Ratcliff)	14
Specimen Transport Pouch	83 - 84
Spencer Suture Scissors	28
Spinal Column Blade	2
Model No. 201-103	2
Spinal Cord Removal Instrument	48
Spreader Bars With Straps	229
Standard Body Tray	168, 175, 179, 190, 192, 221
Standard Carrier	168
Stapler	76
Storage Racks	221 - 226
Cantilever Storage Racks	222
Cantilever Storage Adjustable Racks	223
Mobile Cremation Storage	224
Portable Mortuary Storage	224
Powder Coated Cantilever Storage Rack	223
Two Body Storage Carrier	174, 175, 221

Storage Rack System	225 - 226
Cadaver Lift	228 - 229
Carrier With Rollers	179
Stretcher - Cadaver Chassis	176
St. Vincent's Tube Occluding Clamps	52
Supercut Scissors	17
Suture Needles	75
Suture Thread	77 - 78
Syringe	79 - 80

## T

Teasing Needles	48
Thumb Forceps With Magnifier	35
Tissue Forceps	29, 30, 32, 33, 34, 36
Toe Tags	135, 166
Tracheal Retractors	58
Transport Pouch	83 - 84
Trays, Instrument	65 - 68
Trays and Tops	187 - 192
Triple Chain Hook, 6"	53
Tube Drying Rack	137
Tube Occluding Clamps	52
Tubing	140
Two Body Storage Carrier	174, 175, 221
Tyvek	105 - 106

## U

Universal Carrier	167
U.S. Army Pattern Chisel	51
U.S. Army Pattern Gouge	51
U.S. Army Pattern Osteotomes	50
US Army Retractors	58
Utility Carts	85 - 86

## V

Vacuums, Bone Dust Collector	3, 6
Vacuum Tube Swivel Adapter	138
Vezien's Abdominal Scissors	28
Virchow Post Mortem Knife	14
Virchow Skull Breaker	45
Viscera Bags	134, 166

## W

Water Control Cell	193
Weitlaner Retractors	59
Wrapping Sheets	134

## **Terms of Sale:**

### **PAYMENTS TERMS:**

NET 30 DAYS to those qualifying for open accounts on domestic shipments. Overseas shipment requires payment by Wire Transfer or Letter of Credit. Payments shall be made in U.S. Dollars, unless Salam International, Inc. agrees in writing to invoice in another currency. Time is of the essence in regards to payments of any amounts.

Salam International, Inc. reserves the right to charge a late fee equal to the highest applicable lawful interest rate on an invoiced amount not paid within thirty (30) days of the invoice date.

### **FREIGHT:**

All priced items are F.O.B. Point of Origin. Freight will be added to invoice.

### **RETURNS:**

Merchandise that has been ordered from Salam International, Inc. and has proven defective may be returned to Salam International, Inc. within 15 days for replacement or adjustment, subject to the following conditions.

Products acceptable for full credit:

Products not supplied in accordance with customer's orders.

Products which are defective at the time of receipt by the customer.

Returns other than above reasons are subject up to a 25% restocking charge.

Products not acceptable for credit:

Products which have been discontinued.

Products which are personalized or customized.

Non-Salam International, Inc. line products supplied to a customer as an accommodation.

Products not purchased from Salam International, Inc.

Any product which has been used and sealed reagents, diagnostics, or chemicals which have been opened.

### **PRICES:**

ALL PRICES ARE SUBJECT TO CHANGE WITHOUT NOTICE. All prices are individually priced, unless otherwise noted. At the time of publication, all catalog list prices are current. Not responsible for typographical errors.

### **TAXES:**

Any taxes or any other governmental charge upon production, sales and/or shipment of goods sold hereunder, now imposed by federal, state, and municipal authorities, or hereinafter become effective, shall be added to the price herein and shall be paid by the buyer.

### **MATERIAL AND FINISH CHANGES:**

We reserve the right to make changes at any time, without notice, in specifications and design or to discontinue items and new designs.

### **DAMAGED MERCHANDISE:**

Inspect your shipments IMMEDIATELY and it has to be noted on delivery receipt by the person making the delivery (failure to have the notation made on delivery receipt may void any claims whatsoever). Notify the delivering carrier immediately of any damage. All damages, whether apparent at the time of delivery or concealed, must be reported to the delivering carrier within 48 hours. Our responsibility ceases when shipment is accepted by the carrier.

### **ACCEPTANCE:**

Receipt of our price list does not constitute an offer to sell. All orders subject to acceptance by SALAM INTERNATIONAL, INC.

### **COST OF COLLECTION:**

The buyer agrees to pay all reasonable attorney's fees and other costs of collection.